

Truckee Meadows Regional Drainage Manual

April 30, 2009

Reno

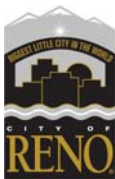

Sparks



Washoe County



TABLE OF CONTENTS

SECTION 100 - INTRODUCTION **107**

SECTION 200 - GENERAL PROVISIONS..... **200**

 201 TITLE 201

 202 ADOPTION AUTHORITY..... 201

 203 JURISDICTION 201

 204 ENFORCEMENT RESPONSIBILITY 201

 205 VARIANCE PROCEDURES 201

 206 INTERPRETATION 202

 207 REVIEW AND APPROVAL 202

 208 IMPLEMENTATION 202

 208.1 DEVELOPMENT OF THE MANUAL..... 202

 208.2 UPDATES..... 202

 208.3 RECONCILIATION OF PRE- AND POST-MANUAL STUDIES..... 203

 209 ACRONYMS..... 203

SECTION 300 - DRAINAGE POLICY **300**

 301 STATUTORY AUTHORITY 301

 302 BASIC PRINCIPLES 302

 302.1 DRAINAGE PLANNING AND REQUIRED SPACE 302

 302.2 MULTI-PURPOSE RESOURCE 303

 302.3 WATER RIGHTS 303

 302.4 JURISDICTIONAL COOPERATION 303

 303 REGIONAL AND LOCAL PLANNING..... 303

 303.1 REASONABLE USE RULE 303

 303.2 REGIONAL MASTER PLANNING..... 304

 303.3 LOCAL MASTER PLANNING..... 304

 303.4 DRAINAGE IMPROVEMENTS 304

 303.5 DRAINAGE PLANNING SUBMITTAL AND REVIEW..... 305

 303.6 FLOOD PLAIN MANAGEMENT..... 305

 303.7 STORM RUNOFF DETENTION..... 306

 303.8 STORM RUNOFF RETENTION..... 307

 303.9 WATER QUALITY AND CONSTRUCTION ACTIVITIES..... 307

 303.10 DRAINAGE FACILITIES MAINTENANCE 308

 304 TECHNICAL CRITERIA 308

 304.1 STORM WATER MANAGEMENT TECHNOLOGY 308

 304.2 DESIGN STORM EVENTS 309

 304.3 STORM RUNOFF DETERMINATION 310

 304.4 STREETS..... 310

 304.5 CULVERTS AND BRIDGES 311

 304.6 FLOODPROOFING 312

TRUCKEE MEADOWS REGIONAL DRAINAGE MANUAL

304.7 ALLUVIAL FANS 312

305 IRRIGATION FACILITIES.....312

305.1 DRAINAGE INTERACTION 312

305.2 IRRIGATION DITCHES..... 312

306 PRESERVATION OF NATURAL DRAINAGEWAYS..... 313

SECTION 400 - DRAINAGE LAW 400

401 INTRODUCTION401

402 HISTORICAL EVOLUTION OF SURFACE WATER DRAINAGE LAW..... 401

402.1 THE COMMON ENEMY DOCTRINE401

402.2 CIVIL LAW RULE402

402.3 REASONABLE USE RULE402

403 NEVADA DRAINAGE LAW 403

403.1 CIVIL LAW RULE403

403.2 REASONABLE USE RULE404

403.3 SURFACE WATERS - PRIVATE DEVELOPMENT406

404 SURFACE WATERS - GOVERNMENTAL ENTITY LIABILITY 410

404.1 SOVEREIGN IMMUNITY410

404.2 NRS 41.032 - DISCRETIONARY IMMUNITY..... 411

404.3 NRS 41.033 - FAILURE TO INSPECT412

404.4 LIMITATION OF TORT DAMAGE AWARDS412

404.5 INVERSE CONDEMNATION - EMINENT DOMAIN..... 413

SECTION 500 - DRAINAGE PLANNING AND SUBMITTAL 500

501 PURPOSE..... 501

502 REQUIRED DRAINAGE REPORT SUBMITTALS 501

502.1 GENERAL 501

502.2 SUBMITTALS..... 502

502.3 EXEMPTIONS 502

502.4 DRAINAGE MASTER PLANS 503

503 CONCEPTUAL DRAINAGE REPORT 503

503.1 REPORT CONTENTS.....503

503.2 DRAINAGE PLAN 504

504 TECHNICAL DRAINAGE REPORT.....505

504.1 REPORT CONTENTS..... 505

504.2 DRAINAGE PLAN509

504.3 CALCULATIONS EXEMPTION 510

504.4 IMPROVEMENT PLANS510

505 TECHNICAL DRAINAGE REPORT ADDENDUM 510

506 IMPROVEMENT PLANS511

507 REQUIREMENTS FOR A FLOOD PLAIN STUDY..... 511

507.1 OUTLINE FOR A FLOOD PLAIN STUDY 512

507.2 FEMA DESIGNATED FLOOD PLAINS 512

SECTION 600 - RAINFALL 600

601	INTRODUCTION	601
602	RAINFALL	601
602.1	RAINFALL FOR CITY OF RENO AND UNINCORPORATED WASHOE COUNTY	601
602.2	RAINFALL FOR CITY OF SPARKS.....	601
603	RAINFALL DISTRIBUTION FOR SCS UNIT HYDROGRAPH METHOD.....	601
603.1	RAINFALL DEPTH - DURATION – FREQUENCY SOURCE	601
603.2	RAINFALL DEPTHS FOR DURATIONS FROM 5 MINUTES TO 24 HOURS	601
603.3	DEPTH-AREA REDUCTION FACTORS.....	602
604	RAINFALL DISTRIBUTION FOR RATIONAL METHOD.....	602
604.1	RAINFALL REGIONS FOR RATIONAL METHOD.....	602
604.2	TIME-INTENSITY-FREQUENCY CURVES IN REGION 1.....	603
604.3	TIME-INTENSITY-FREQUENCY CURVES IN REGION 2.....	603
604.4	TIME-INTENSITY-FREQUENCY CURVES IN REGION 3.....	603
SECTION 700 - STORM RUNOFF		700
701	INTRODUCTION	702
701.1	BASIN CHARACTERISTICS	702
702	TIME OF CONCENTRATION	702
702.1	URBANIZED BASINS	703
703	PRECIPITATION LOSSES	704
703.1	INTRODUCTION	704
703.2	SCS CURVE NUMBER METHOD	705
704	RATIONAL FORMULA METHOD	706
704.1	METHODOLOGY.....	706
704.2	ASSUMPTIONS	707
704.3	LIMITATIONS ON METHODOLOGY	707
704.4	RAINFALL INTENSITY	707
704.5	RUNOFF COEFFICIENT	707
704.6	APPLICATION OF THE RATIONAL FORMULA METHOD.....	708
704.7	MAJOR STORM ANALYSIS.....	708
705	SCS UNIT HYDROGRAPH METHOD.....	708
705.1	METHODOLOGY.....	708
705.2	ASSUMPTIONS	709
705.3	LAG TIME.....	709
705.4	UNIT STORM DURATION.....	710
705.5	SUB-BASIN SIZING	710
706	CHANNEL ROUTING OF HYDROGRAPHS	711
707	RESERVOIR ROUTING OF HYDROGRAPHS	711
707.1	MODIFIED PULS METHOD	712
708	STATISTICAL ANALYSIS	712
709	VOLUME OF RUNOFF AND STORAGE VOLUMES	713
709.1	GENERAL.....	713
709.2	NORTH VALLEYS (CITY OF RENO AND WASHOE COUNTY ONLY).....	713
709.3	FLOOD PLAIN STORAGE WITHIN THE TRUCKEE RIVER WATERSHED	714

710	GREEN AND APMT METHOD (PLACEHOLDER FOR FUTURE SECTION).....	714
711	EXAMPLE APPLICATIONS	714
711.1	EXAMPLE: RATIONAL FORMULA METHOD.....	714
711.2	EXAMPLE: SCS UNIT HYDROGRAPH METHOD	716
SECTION 800 - OPEN CHANNELS		800
801	INTRODUCTION	803
802	OPEN CHANNEL HYDRAULICS	803
802.1	UNIFORM FLOW	803
802.2	UNIFORM CRITICAL FLOW ANALYSIS	804
802.3	GRADUALLY VARYING FLOW	805
802.4	RAPIDLY VARYING FLOW.....	805
802.5	TRANSITIONS	806
803	CHANNEL SELECTION	806
803.1	CHANNEL TYPES	806
803.2	CHANNEL SELECTION.....	807
803.3	MAXIMUM PERMISSIBLE VELOCITIES.....	809
804	NATURAL CHANNEL DESIGN	809
804.1	INTRODUCTION	809
804.2	NATURAL CHANNEL MORPHOLOGY AND RESPONSE.....	812
804.3	NATURAL CHANNEL DESIGN.....	821
804.4	NATURAL CHANNEL STABILIZATION	831
804.5	FLOOD PLAIN MANAGEMENT OF NATURAL CHANNELS.....	833
805	IMPROVED CHANNEL DESIGN.....	834
805.1	GENERAL REQUIREMENTS	834
805.2	PERMANENT UNLINED CHANNELS	835
805.3	NON-REINFORCED GRASS-LINED CHANNELS	835
805.4	WETLAND BOTTOM CHANNELS	838
805.5	RIPRAP-LINED CHANNELS	840
805.6	CONCRETE-LINED CHANNELS	848
805.7	OTHER CHANNEL LININGS	851
806	ADDITIONAL HYDRAULIC DESIGN STANDARDS	855
806.1	SUBCRITICAL FLOW DESIGN STANDARDS.....	856
806.2	SUPERCRITICAL FLOW DESIGN STANDARDS	858
807	CHANNEL APPURTENANCES	861
807.1	MAINTENANCE ACCESS ROAD	861
807.2	SAFETY REQUIREMENTS.....	861
807.3	CULVERT OUTLET PROTECTION	862
807.4	GRADE CONTROL STUCTURES	863
808	EXAMPLE APPLICATION	869
808.1	EXAMPLE: OPEN CHANNEL DESIGN FOR DOE CREEK.....	869
808.2	EXAMPLE: DETERMINE EQUILIBRIUM SLOPE BY THE THREE SLOPE METHOD ...	871
808.3	EXAMPLE: DETERMINE THE EQUILIBRIUM SLOPE BY POWER RELATIONS	872

SECTION 900 - STORM SEWER SYSTEM	900
901 INTRODUCTION	902
902 DESIGN PARAMETERS	902
902.1 ALLOWABLE STORM SEWER CAPACITY	902
902.2 ALLOWABLE STORM SEWER VELOCITY	903
902.3 MANNING'S ROUGHNESS COEFFICIENT	903
902.4 STORM SEWER LAYOUT	903
902.5 ALLOWABLE STORM INLET TYPES AND CAPACITY FACTORS	905
902.6 OTHER CLOSED CONDUIT CRITERIA	905
903 CONSTRUCTION STANDARDS	905
903.1 STORM SEWER PIPE	905
903.2 MANHOLES	906
903.3 STORM SEWER INLETS	906
903.4 STORM SEWER OUTLETS	906
904 STORM SEWER HYDRAULICS	906
904.1 HYDRAULIC ANALYSIS	906
904.2 ENERGY LOSS CALCULATIONS	907
905 STORM INLET HYDRAULICS	910
905.1 INLETS ON CONTINUOUS GRADE	911
905.2 INLETS IN A SUMP CONDITION	912
905.3 INLET SPACING	913
905.4 INLET CAPACITY FOR MAJOR STORM ANALYSIS	913
906 STORM SEWER SYSTEM DESIGN	914
906.1 INITIAL STORM SEWER SIZING	914
906.2 FINAL STORM SEWER SIZING	914
907 EXAMPLE APPLICATION	915
907.1 INTRODUCTION	915
907.2 EXAMPLE: STORM SEWER HYDRAULIC ANALYSIS	915
SECTION 1000 - STREETS	1000
1001 INTRODUCTION	1001
1002 FUNCTION OF STREETS IN THE DRAINAGE SYSTEM	1001
1003 DRAINAGE IMPACTS ON STREETS	1001
1003.1 SHEET FLOW	1002
1003.2 GUTTER FLOW	1002
1003.3 TEMPORARY PONDING	1002
1003.4 CROSS FLOW	1002
1004 DRAINAGE IMPACT ON STREET MAINTENANCE	1003
1004.1 PAVEMENT DETERIORATION	1003
1004.2 SEDIMENTATION AND DEBRIS	1003
1005 STREET CLASSIFICATION AND ALLOWABLE FLOW DEPTH	1004
1006 HYDRAULIC EVALUATION	1004
SECTION 1100 - CULVERTS AND BRIDGES	1100

1101	INTRODUCTION	1102
1102	DESIGN STANDARDS FOR CULVERTS	1102
1102.1	CULVERT SIZING CRITERIA	1102
1102.2	CONSTRUCTION MATERIALS	1102
1102.3	VELOCITY LIMITATIONS AND INLET/OUTLET PROTECTION.....	1103
1102.4	HEADWATER CRITERIA	1103
1102.5	ALIGNMENT	1104
1102.6	TEMPORARY CROSSING	1104
1102.7	MULTIPLE-BARREL CULVERTS	1104
1102.8	TRASH RACKS/SAFETY GRATES.....	1105
1102.9	AIR VENTS.....	1105
1102.10	MAINTENANCE ACCESS	1105
1103	CULVERT HYDRAULICS	1105
1103.1	INLET CONTROL CONDITION	1106
1103.2	OUTLET CONTROL CONDITION	1106
1103.3	HYDRAULIC DATA	1107
1103.4	STRUCTURAL DESIGN.....	1107
1104	DESIGN STANDARDS FOR BRIDGES	1108
1104.1	BRIDGE SIZING CRITERIA	1108
1104.2	VELOCITY LIMITATIONS.....	1108
1105	BRIDGE HYDRAULICS.....	1108
1105.1	HYDRAULIC ANALYSIS	1108
1105.2	INLET AND OUTLET CONFIGURATION	1108
1106	EXAMPLE APPLICATION	1108
1106.1	EXAMPLE: CULVERT SIZING	1108
SECTION 1200 - ADDITIONAL HYDRAULIC STRUCTURES		1200
1201	INTRODUCTION	1201
1202	CHANNEL DROPS AND ENERGY DISSIPATION STRUCTURES.....	1201
1202.1	CHANNEL DROP STRUCTURES.....	1201
1202.2	ENERGY DISSIPATION STRUCTURES	1207
SECTION 1300 - DETENTION		1300
1301	INTRODUCTION	1302
1301.1	DEFINITION OF REGIONAL FACILITIES	1302
1301.2	DEFINITION OF LOCAL FACILITIES	1302
1302	DETENTION/RETENTION DESIGN GUIDELINES AND STANDARDS	1303
1302.1	REGIONAL DETENTION.....	1303
1302.2	LOCAL DETENTION.....	1304
1303	HYDROLOGIC DESIGN METHODS AND CRITERIA	1306
1303.1	INFLOW HYDROGRAPH	1306
1303.2	DETENTION BASIN DESIGN OUTFLOW LIMITATIONS	1306
1303.3	HYDROLOGIC CALCULATION METHODS.....	1307
1304	OUTLET STRUCTURES	1308

1304.1	LOW FLOW OUTLETS.....	1308
1304.2	SPILLWAYS	1310
1305	DEBRIS AND SEDIMENTATION	1311
1305.1	TRASH RACKS	1311
1305.2	SEDIMENTATION	1311
1305.3	SEDIMENT YIELD ESTIMATION	1312
1306	DESIGN STANDARDS AND CONSIDERATIONS.....	1315
1306.1	DAM SAFETY	1315
1306.2	GRADING REQUIREMENTS	1315
1306.3	DEPTH LIMITS	1315
1306.4	LOW FLOW AND BASIN DEWATERING	1315
1306.5	EMBANKMENT PROTECTION	1315
1306.6	MAINTENANCE REQUIREMENTS.....	1315
1306.7	LOCAL DETENTION BASIN SITING GUIDELINES	1316
1307	EXAMPLE APPLICATIONS	1316
1307.1	EXAMPLE: DETENTION POND OUTLET SIZING.....	1316
1307.2	EXAMPLE: RATIONAL FORMULA DETENTION METHOD	1317
SECTION 1400 - EROSION AND SEDIMENTATION.....		1400
1401	DEBRIS CONTROL STRUCTURES AND BASINS	1401
1401.1	INTRODUCTION	1401
1401.2	DEBRIS DEFLECTORS	1401
1401.3	DEBRIS RACKS	1401
1401.4	DEBRIS RISERS	1402
1401.5	DEBRIS CRIBS	1402
1401.6	DEBRIS DAMS AND BASINS	1402
1401.7	SIZING OF CONTROL STRUCTURES AND BASINS	1402
1401.8	SITING OF CONTROL STRUCTURES AND BASINS	1403
SECTION 1500 - STANDARD FORMS		1500
SECTION 1600 - REFERENCES		1600

LIST OF TABLES

601	CITY OF SPARKS RAINFALL DEPTH-DURATION-FREQUENCY DATA, REGION 1
602	CITY OF SPARKS RAINFALL DEPTH-DURATION-FREQUENCY DATA, REGION 2
603	CITY OF SPARKS RAINFALL DEPTH-DURATION-FREQUENCY DATA, REGION 3
701	RATIONAL FORMULA METHOD RUNOFF COEFFICIENTS
702	RUNOFF CURVE NUMBERS
703	LAG EQUATION ROUGHNESS FACTORS
704	EXAMPLE: RATIONAL FORMULA METHOD RESULTS
801	GEOMETRIC ELEMENTS OF CHANNEL SECTIONS
802	TYPICAL ROUGHNESS COEFFICIENTS FOR OPEN CHANNELS
803	MAXIMUM PERMISSIBLE MEAN CHANNEL VELOCITIES
804	POTENTIAL EFFECTS OF MAJOR MAN-MADE DISTURBANCES
805	POWER EQUATIONS FOR TOTAL BED MATERIAL DISCHARGE IN SAND- AND FINE- GRAVEL-BED STREAMS
806	RANGE OF PARAMETERS FOR THE SIMONS-LI-FULLERTON METHOD
807	CHECKLIST OF DATA NEEDS FOR NATURAL CHANNEL ANALYSIS
808	SUMMARY OF APPLICATIONS OF STREAM STABILIZATION TECHNIQUES
809	RIPRAP GRADATION FOR STEEP SLOPES
901	STORM SEWER DESIGN AND ANALYSIS PARAMETERS
902	ALLOWABLE STORM INLET TYPES AND CAPACITY FACTORS
903	STORM SEWER ENERGY LOSS COEFFICIENTS
904	SPLASH VELOCITY CONSTANTS FOR VARIOUS TYPES OF GRATES
905	SAG INLET PARAMETERS AND COEFFICIENTS
1101	HYDRAULIC DATA FOR CULVERTS – CULVERT ENTRANCE LOSSES
1201	CHANNEL DROP AND ENERGY DISSIPATION STRUCTURES
1202	SLOPING GROUTED BOULDER DROP DESIGN PARAMETERS
1203	SLOPING GROUTED BOULDER DROP ROCK AND GROUT THICKNESS
1301	CONSERVATION PRACTICE FACTOR P FOR CONTOURING, STRIP CROPPING AND TERRACING
1302	INFLOW HYDROGRAPH AND BASIN CHARACTERISTICS FOR EXAMPLE IN SECTION 1307.1
1303	HEC-1 RUN FOR EXAMPLE IN SECTION 1307.1
1401	DEBRIS STRUCTURE PERFORMANCE

LIST OF FIGURES

601	CITY OF SPARKS REGION BOUNDARIES
602	CITY OF SPARKS RAINFALL INTENSITY DURATION FREQUENCY CURVE, REGION 1
603	CITY OF SPARKS RAINFALL INTENSITY DURATION FREQUENCY CURVE, REGION 2
604	CITY OF SPARKS RAINFALL INTENSITY DURATION FREQUENCY CURVE, REGION 3
605	CITY OF SPARKS DEPTH-AREA REDUCTION CURVE
606	EXAMPLE: HEC-1 INPUT AND OUTPUT FOR BASIN A
701	TRAVEL TIME VELOCITY
702	PERCENTAGE OF IMPERVIOUS AREA VS. COMPOSITE CNs FOR GIVEN PERVIOUS AREA CNs
703	PROPOSED ROSE SUBDIVISION
704	EXAMPLE: HEC-1 INPUT AND OUTPUT DATA FOR BASIN A
801	OPEN-CHANNEL FLOW CONDITIONS
802	CRITICAL DEPTH FOR TRAPEZOIDAL AND CIRCULAR SECTIONS
803	TYPICAL OPEN CHANNEL DESIGN SECTIONS (NATURAL CHANNEL)
804	ILLUSTRATION OF TERMINOLOGY FOR BEND-SCOUR CALCULATIONS
805	FORCES ACTING ON A CHANNEL BANK ASSUMING THERE IS A ZERO PORE WATER PRESSURE
806	STABILITY NUMBER (NS) AS A FUNCTION OF BANK ANGLE (I) FOR A FAILURE SURFACE PASSING THROUGH THE BANK TOE
807	EXAMPLE OF BANK STABILITY CHART FOR ESTIMATING CRITICAL BANK HEIGHT
808	CRITICAL BANK-SLOPE CONFIGURATIONS FOR VARIOUS RANGES OF COHESIVE STRENGTHS UNDER SATURATED CONDITIONS
809	TYPICAL OPEN-CHANNEL DESIGN SECTIONS (IMPROVED CHANNELS)
810	ROUGHNESS COEFFICIENT FOR GRASS-LINED CHANNELS
811	TYPICAL CROSS-SECTION OF CONCRETE-LINED LOW-FLOW CHANNEL
812	TYPICAL CROSS-SECTION OF RIPRAP-LINED LOW-FLOW CHANNEL
813	TYPICAL CROSS-SECTION OF LOW-FLOW CHANNEL
814	MANNINGS ROUGHNESS COEFFICIENT FOR WETLAND BOTTOM
815	TYPICAL CROSS-SECTION FOR RIPRAP-LINED CHANNELS
816	TYPICAL CROSS-SECTION FOR GROUTED RIPRAP LINING
817	TYPICAL GROUTED RIPRAP SECTION
818A	OPTIMUM RIPRAP SIDE SLOPE FOR A GIVEN SIZE RIPRAP
818B	RIPRAP END PROTECTION
818C	TOE PROTECTION ALTERNATIVES
818D	TOE PROTECTION
818E	LAUNCHING TOE MATERIAL
818F	“DUTCH” TOE
819	STEEP SLOPE RIPRAP DESIGN, TRIANGULAR CHANNELS, 2:1 SIDESLOPES
820	STEEP SLOPE RIPRAP DESIGN, TRAPEZOIDAL CHANNELS, 2:1 SIDESLOPES, 6 FT BASE WIDTH
821	STEEP SLOPE RIPRAP DESIGN, TRAPEZOIDAL CHANNELS, 2:1 SIDESLOPES, 10 FT BASE WIDTH

822	STEEP SLOPE RIPRAP DESIGN, TRAPEZOIDAL CHANNELS, 2:1 SIDESLOPES, 14 FT BASE WIDTH
823	STEEP SLOPE RIPRAP DESIGN, TRAPEZOIDAL CHANNELS, 2:1 SIDESLOPES, 20 FT BASE WIDTH
824	SLOPE GABION MATTRESS LINING
825	CHANNEL TRANSITION TYPES
826	TYPICAL CHANNEL TRANSITION SECTIONS AND ENERGY LOSS COEFFICIENTS
827	TYPICAL CONTRACTING TRANSITION FOR SUPERCRITICAL FLOW
828	DESIGN CHART FOR CONTRACTING TRANSITION FOR SUPERCRITICAL FLOW
829	CONFIGURATION OF CULVERT OUTLET PROTECTION
830	PREFORMED SCOUR HOLE
831	SPACING OF GRADE CONTROL STRUCTURE
832A	AS BUILT RIPRAP GRADE CONTROL STRUCTURE WITH SUFFICIENT LAUNCH STONE TO HANDLE ANTICIPATED SCOUR
832B	LAUNCHING OF RIPRAP AT GRADE CONTROL STRUCTURE IN RESPONSE TO BED DEGRADATION AND LOCAL SCOUR
833A	AS BUILT RIPRAP GRADE CONTROL STRUCTURE WITH IMPERVIOUS FILL CUTOFF WALL
833B	LAUNCHING OF RIPRAP AT GRADE CONTROL STRUCTURE IN RESPONSE TO BED DEGRADATION AND LOCAL SCOUR
834A	AS BUILT RIPRAP GRADE CONTROL STRUCTURE WITH SHEET PILE CUTOFF WALL
834B	LAUNCHING OF RIPRAP AT GRADE CONTROL STRUCTURE IN RESPONSE TO BED DEGRADATION AND LOCAL SCOUR
835	SLOPING DROP GRADE CONTROL STRUCTURE WITH PRE-FORMED RIPRAP LINED SCOUR HOLE
836	BED STABILIZER DESIGN WITH SHEET PILE CUTOFF
837	ARS-TYPE GRADE CONTROL STRUCTURE WITH PRE-FORMED RIPRAP LINED STILLING BASIN AND BAFFLE PLATE
838	SCHEMATIC OF MODIFIED ARS-TYPE GRADE CONTROL STRUCTURE
839	CIT-TYPE DROP STRUCTURE
840	ST. ANTHONY FALLS (SAF) TYPE DROP STRUCTURE
841	CONTROL SILL GRADE CONTROL STRUCTURE
842	EXAMPLE: CROSS-SECTION OF DOE CREEK
843	DEGRADED CHANNEL PROFILE BY THE THREE-SLOPE METHOD
901	HYDRAULIC PROPERTIES OF CIRCULAR PIPE
902	HYDRAULIC PROPERTIES OF HORIZONTAL ELLIPTICAL PIPE
903	HYDRAULIC PROPERTIES OF ARCH PIPE
904	ENERGY LOSS COEFFICIENT IN STRAIGHT THROUGH MANHOLE
905	EXAMPLE PROBLEM: SCHEMATIC DRAWING OF STORM SEWER SYSTEM
906	EXAMPLE PROBLEM: STORM SEWER PROFILE
907	EXAMPLE PROBLEM: STORM SEWER HYDRAULIC CALCULATIONS (STANDARD FORM – 3)
1101	CULVERT ALIGNMENT
1102	CULVERT FLOW TYPES

1103	NOMOGRAPH – INLET CONTROL BOX CULVERT
1104	NOMOGRAPH – INLET CONTROL RCP
1105	NOMOGRAPH – INLET CONTROL ELLIPTICAL PIPE
1106	OUTLET CONTROL CULVERT HYDRAULICS
1107	NOMOGRAPH – CRITICAL DEPTH
1108	NOMOGRAPH – CRITICAL DEPTH
1109	NOMOGRAPH – CRITICAL DEPTH
1110	NOMOGRAPH – OUTLET CONTROL BOX CULVERT
1111	NOMOGRAPH – OUTLET CONTROL RCP
1112	NOMOGRAPH – OUTLET CONTROL ELLIPTICAL PIPE
1113	EXAMPLE: NOMOGRAPH – INLET CONTROL 5-FOOT DIAMETER RCP
1114	EXAMPLE: NOMOGRAPH – CRITICAL DEPTH – CIRCULAR PIPE - 5-FOOT DIAMETER RCP
1115	EXAMPLE: NOMOGRAPH – OUTLET CONTROL RCP (n = 0.012) - 5-FOOT DIAMETER RCP
1201	DROP STRUCTURES
1202	SLOPING GROUTED BOULDER DROP
1203	SLOPING GROUTED BOULDER DROP SCHEMATIC
1204	TYPICAL GROUTED BOULDER PLACEMENT
1205	WEEP DRAIN SYSTEM DETAILS
1206	VERTICAL RIPRAP DROP
1207	CURVES FOR SCOUR DEPTH AT VERTICAL DROP
1208	STRAIGHT DROP SPILLWAY
1209	BAFFLED APRON STILLING BASIN (USBR TYPE IX)
1210	DESIGN DATA – USBR TYPE STILLING BASINS
1211	SHORT STILLING BASIN (USBR TYPE III)
1212	LOW FROUDE NUMBER STILLING BASIN (USBR TYPE IV)
1213	IMPACT STILLING BASIN (USBR TYPE VI)
1214	TYPICAL TRAJECTORY TRANSITION
1301	TYPICAL BASIN GEOMETRY
1302	V-NOTCH WEIR COEFFICIENTS
1303	OGEE-CRESTED WEIR COEFFICIENTS
1304	SOIL ERODIBILITY NOMOGRAPH USED TO DETERMINE FACTOR K (TONS/ACRE) FOR SPECIFIC TOPSOILS OR SUBSOIL HORIZONS
1305	FACTOR FOR CANOPY EFFECT
1306	EFFECT OF PLANT RESIDUES OR CLOSE-GROWING STEMS AT THE SOIL SURFACE
1307	TYPE III EFFECTS ON UNDISTURBED LAND AREAS
1308	HYDROGRAPH FOR EXAMPLE IN SECTION 1307.2
1401	TYPICAL DEBRIS CRIB
STANDARD FORM 1	DRAINAGE REPORT SUBMITTAL CHECKLIST
STANDARD FORM 2	TIME OF CONCENTRATION
STANDARD FORM 3	STORM SEWER HYDRAULIC CALCULATIONS
STANDARD FORM 4	CULVERT DESIGN

SECTION 100 - INTRODUCTION

GENERAL INDEX

SECTION 100	-	INTRODUCTION
SECTION 200	-	GENERAL PROVISIONS
SECTION 300	-	DRAINAGE POLICY
SECTION 400	-	DRAINAGE LAW
SECTION 500	-	DRAINAGE PLANNING AND SUBMITTAL
SECTION 600	-	RAINFALL
SECTION 700	-	STORM RUNOFF
SECTION 800	-	OPEN CHANNELS
SECTION 900	-	STORM SEWER SYSTEMS
SECTION 1000	-	STREETS
SECTION 1100	-	CULVERTS AND BRIDGES
SECTION 1200	-	ADDITIONAL HYDRAULIC STRUCTURES
SECTION 1300	-	DETENTION
SECTION 1400	-	EROSION AND SEDIMENTATION
SECTION 1500	-	STANDARD FORMS
SECTION 1600	-	REFERENCES

PURPOSE

The purpose of this Manual is to ensure consistency in analysis, planning and design of projects with flood control and drainage components within the Jurisdictional Entities (Reno, Sparks and Washoe County). This Manual is a single reference for policies and criteria relating to drainage design and hydrology for the jurisdictional entities. The adoption of this Manual by the Jurisdictional Entities will aid in both the regulation of future development within the region, as well as floodplain management within the region.

REVISIONS

This Manual has been prepared using current state-of-the-art technology and procedures. Due to the dynamic nature of urban storm drainage, amendments and revisions will be required from time to time as technology advances the state-of-the-art and experience is gained from the use of this Manual. It is envisioned that updates will occur at a minimum of every 3 years from the published date.

Users of this Manual are encouraged by the Jurisdictional Entities to submit any comments concerning the content or application of this Manual. Comments should be directed to:

City of Reno

Deputy Director of Community Development and Engineering
775-334-2063

City of Sparks

Engineering Manager of Community Development
775-353-2371

or

Public Works Director
775-353-2300

Washoe County

Public Works Director
775-328-2040

The entire Manual is available to download from the Washoe County website: www.washoecounty.us and a hardcopy is available for inspection at:

Washoe County Public Works Department, Engineering Division
1001 East Ninth Street, Second Floor
Reno, Nevada

Several publications referenced in the Manual may be found on the following websites:

- Truckee Meadows Construction Site Best Management Practices Handbook
www.ci.reno.nv.us/pub_works/stormwater
- Truckee Meadows Structural Controls Design Manual
www.ci.reno.nv.us/pub_works/stormwater

The City of Reno, the City of Sparks and Washoe County, for the unincorporated area, have requirements in addition to those presented in this Manual. These requirements may be found at the following websites:

- City of Reno, Nevada www.ci.reno.nv.us
- City of Sparks, Nevada www.ci.sparks.nv.us
- Unincorporated Washoe County, Nevada www.washoecounty.us

All Manual users are encouraged to periodically check the Washoe County website www.washoecounty.us for updates and amendments to this Manual.

ACKNOWLEDGEMENTS

Washoe County and WRC Engineering, Inc. wish to acknowledge and thank all individuals and committee members who provided technical review of the draft standards and criteria during the revision of this Manual. The review process for the 2009 Manual began in August 2005 and was finalized in the spring of 2009. We wish to specifically acknowledge the contributions of the following members of the Technical Review Committee who provided specific input to the Manual. Listed below are committee members and their titles at the time of their participation:

Washoe County	Jeanne Ruefer, Water Resource Planning Manager Paul Urban, P.E., Flood Control Manager Jim Smitherman, Water Resources Program Manager Kristine Klein, P.E., Public Works James Shaffer, Environmental Health Services Division Warren Call, P.E., Regional Transportation Commission Brenda Lee, P.E., Regional Transportation Commission
City of Reno	Glen B. Daily, P.E., Public Works Terri Svetich, P.E., Public Works Joseph Coudriet, P.E., Public Works Kerri Williams-Lanza, P.E., Public Works Al Pelly, P.E., Community Development
City of Sparks	Shawn Gooch, P.E. Public Works Janelle Thomas, P.E., Public Works
Nevada Division of Water Resources	Robert Martinez, P.E., Engineering and Dam Safety Michael Anderson, P.E., Engineering and Dam Safety Kim Groenewold, Floodplain Management
Nevada Department of Transportation	Amir Soltani, P.E., Chief Hydraulic Engineer Paul Frost, P.E., Hydraulic Engineer
Kennedy/Jenks Consultants	Chris Conway, representing the Engineering Community
Nimbus Engineers	Peggy Bowker, P.E., representing the Engineering Community

Alan J. Leak, P.E., Project Manager, President, WRC Engineering, Inc. and staff contributed to the preparation and completion of this 2008 Manual.

Washoe County and WRC Engineering, Inc. wish to acknowledge and thank all individuals and committee members who provided technical review during the preparation of the original 1996 Manual.

Original 1996 Manual Team

Washoe County	David T. Price Leonard Crowe Kris Klein Kirk Nichols
Consulting Engineers Council of NV	Peter Etchart, SEA Engineering
City of Reno	Bob Gottsacker Glen Daily
Natural Resources Conservation Service (NRCS)	John McClung
American Society of Civil Engineers	Mark Forest, Harding Lawson Alpha
Desert Research Institute	John Fordham
Nevada Department of Transportation	Amir Soltani
City of Carson City	Jay Aldean Tim Homann

The 1996 Manual was prepared by WRC Engineering, Inc.:

A.S. "Andy" Andrews - Principal-In-Charge
Alan J. Leak - Project Manager

The following individuals prepared selected sections of the 1996 Manual for WRC Engineering, Inc.:

Charles MacQuaire - Lumos and Associates, Inc.
Michael K. Mansfield - Attorney-at-Law

**PUBLIC WORKS
DEPARTMENT**
1 East 1st Street, 8th Floor
PO Box 1900
Reno, NV 89505

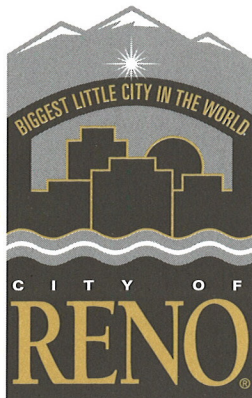

May 28, 2009

Jim Smitherman
Water Resources Program Manager
Department of Water Resources
4930 Energy Way
Reno, NV 89502

Dear Mr. Smitherman:

This letter is being provided, as requested, to show support for the use of (upon completion) the final draft of the Truckee Meadows Regional Drainage Manual that is currently being prepared by the Manual Review Committee.

The City of Reno Public Works supports the work done by the Technical Review Committee in preparing the Truckee Meadows Regional Drainage Manual for use by the Jurisdictional Entities. The City of Reno Public Works provides an endorsement for the use of this manual by making reference to it in Chapter II of the latest revision of the City of Reno Public Works Design Manual.

Sincerely,

A handwritten signature in blue ink that reads "Neil Mann". The signature is fluid and cursive, with a long horizontal stroke at the end.

Neil Mann, P.E.
City of Reno, Public Works Director

NM:jc



PUBLIC WORKS DEPARTMENT

June 11, 2009

Mr. Jim Smitherman
Water Resources Program Manager
Department of Water Resources
4930 Energy Way
Reno, NV 89502

RE: Truckee Meadows Regional Drainage Manual

Dear Mr. Smitherman:

This letter is being provided to support the use of the final draft of the Truckee Meadows Regional Drainage Manual for development of drainage studies within the City of Sparks, as prepared and funded by the Regional Water Planning Commission.

The City of Sparks Public Works Department supports the work done by the Technical Review Committee in preparing the Truckee Meadows Regional Drainage Manual for use by the Jurisdictional Entities. I would like to extend my deepest appreciation to the Committee for the hard work and dedication toward the completion of this drainage manual for the region.

Sincerely,

A handwritten signature in blue ink that reads "Wayne A. Seidel".

Wayne A. Seidel, P.E.
Sparks Public Works Director

Cc: Shaun Carey, City Manager
Randy Mellinger, Assistant City Manager
Neil Krutz, Community Development Director
JoAnn Meacham, Utility Manager
Janelle Thomas, Civil Engineer



WASHOE COUNTY

Department of Public Works
"Dedicated to Excellence in Public Service"

Dan St. John, Public Works Director

1001 East 9th Street PO Box 11130 Reno, Nevada 89520 Telephone: (775) 328-2040 Fax: (775) 328-3699

INTEROFFICE MEMORANDUM

DATE: February 11, 2009
TO: Jim Smitherman, Water Resources Program Manager
FROM: David T. Price, P.E., County Engineer *DTP*
SUBJECT: Truckee Meadows Regional Drainage Manual (TMRDM)

Jim,

As you requested I have prepared the following statement concerning Washoe County's position on future use of the final draft of the TMRDM that is currently being prepared by the Manual Review Committee.

Washoe County supports the work done by the Technical Review Committee in preparing the Drainage Manual for use by the Jurisdictional Entities. Washoe County's intent is to adopt the Manual by reference in the Department of Community Development Code Section 110.420 (drainage).

DTP/ke

SECTION 200 - GENERAL PROVISIONS

TABLE OF CONTENTS

	<u>Page</u>
SECTION 200 - GENERAL PROVISIONS	200
201 TITLE	201
202 ADOPTION AUTHORITY	201
203 JURISDICTION	201
204 ENFORCEMENT RESPONSIBILITY	201
205 VARIANCE PROCEDURES	201
206 INTERPRETATION	202
207 REVIEW AND APPROVAL	202
208 IMPLEMENTATION	202
208.1 DEVELOPMENT OF THE MANUAL	202
208.2 UPDATES	202
208.3 RECONCILIATION OF PRE- AND POST-MANUAL STUDIES	203
209 ACRONYMS	203

SECTION 200

GENERAL PROVISIONS

201 TITLE

These criteria and design standards with all future amendments and revisions shall be known as the "Washoe County Hydrologic Criteria and Drainage Design Manual" (herein referred to as the Manual).

202 ADOPTION AUTHORITY

Nevada Revised Statute (NRS) 278.326 authorizes the adoption of ordinances that specify improvements that must be made.

The appropriate local codes for the Jurisdictional Entities (the City of Reno, the City of Sparks and Washoe County) establish guidelines and requirements for development of properties within areas subject to flooding, and set standards for development of drainage and flood control facilities within the respective jurisdictions.

203 JURISDICTION

These criteria and design standards shall apply to all unincorporated areas within the boundaries of Washoe County excluding the Pyramid Lake Indian Reservation, and the Reno Sparks Indian Colony. In addition, this Manual also applies to the incorporated areas of the Cities of Reno and Sparks upon adoption.

204 ENFORCEMENT RESPONSIBILITY

The Jurisdictional Entities are each charged with enforcement of the Manual for all Drainage and Flood Control Facilities within their respective jurisdictional boundaries.

205 VARIANCE PROCEDURES

Variations to this Manual may be requested for the following reasons:

1. Unusual situations where strict compliance with the Manual may not act to protect the public health and safety.
2. Unusual situations which require additional analysis outside the scope of this Manual for which the additional analysis shows that strict compliance with the Manual may not act to protect the public health and safety.
3. Unusual hydrologic and/or hydraulic conditions which cannot be adequately addressed by strict compliance with the Manual.

Conditions which are created by improper site planning (i.e. lack of adequate space allocations) shall not be considered as grounds for a variance request.

If the subdivider (developer, builder, etc.) believes that a variance to the minimum standards in this Manual is warranted based on the reasons listed above they may request a variance from the minimum standards.

206 INTERPRETATION

In the interpretation and application of the provisions of this Manual, the following shall govern:

1. The provisions shall be regarded as the minimum requirements for the protection of the public health, safety, comfort, convenience, welfare, property, and commerce of the residents of Washoe County and the Jurisdictional Entities. This Manual shall therefore be regarded as remedial and shall be liberally construed to further its underlying purposes.
2. Examples in the Manual do not reflect actual design scenarios, and are intentionally simplistic. They provide a minimal amount of guidance for a limited number of the equations in the Manual, but they are not intended to represent final design level calculations. It is ultimately the responsibility of the designer to select and implement design methodologies that are appropriate to each project.
3. Whenever a provision of this Manual or any provisions in any law, ordinance, resolutions, rule, or regulation of any kind, contain any restrictions covering any of the same subject matter, whichever restrictions are more restrictive or impose higher standards of requirements shall govern.

207 REVIEW AND APPROVAL

All drainage plans, reports, construction drawings and specifications shall be reviewed in accordance with the provisions of this Manual. This review and approval shall not relieve the owner, engineer, or designer from responsibility of ensuring that the calculations, plans, specifications, and construction drawings are in compliance with the provisions of this Manual.

The owner, developer, engineer, and designer must also understand that the Jurisdictional Entities do not and will not assume liability for the drainage facilities designed and/or certified by the engineer. In addition, the Jurisdictional Entities cannot guarantee that drainage design review and approval will absolve the owner, developer, engineer, designer, and/or their successors and/or assigns of future liability for improper design.

208 IMPLEMENTATION

208.1 DEVELOPMENT OF THE MANUAL

The Jurisdictional Entities developed this Manual for use by consulting engineers, as well as their own use. This Manual shall be used for the development and design of all Drainage and Flood Control Facilities.

208.2 UPDATES

The Manual will be updated from time to time as determined to be necessary by the Jurisdictional Entities. The process by which these updates will be accomplished will be dependent upon the nature of the update and will be determined by the Jurisdictional Entities. The Jurisdictional Entities may also add requirements for use in their local jurisdiction, which are in addition to the requirements stated herein. It is envisioned that updates will occur at a minimum of every 3 years from the published date.

208.3 RECONCILIATION OF PRE- AND POST-MANUAL STUDIES

1. Developments for which the technical drainage reports or construction drawings have been approved prior to implementation of this Manual are exempt from the provisions of this updated version of the Manual.
2. Developments for which a conceptual drainage report has been approved prior to implementation of this Manual are exempt from the provisions of this updated version of the Manual if a technical drainage report and/or analysis is submitted for review within 180 days of the implementation of this updated version of Manual.
3. Developments for which drainage reports have not been submitted by the time of implementation of this Manual shall be analyzed in conformance with the provisions of this updated version of Manual.

209 ACRONYMS

The following acronyms are used within the contents of this Manual.

CAP	Corrugated Aluminum Pipe
CAPA	Corrugated Aluminum Pipe Arch
CEC	Consulting Engineers Council
CLOMR	Conditional Letter of Map Revision
CMP	Corrugated Metal Pipe
CMPA	Corrugated Metal Pipe Arch
CSP	Corrugated Steel Pipe
CSPA	Corrugated Steel Pipe Arch
EGL	Energy Grade Line
EPA	Environmental Protection Agency
FEMA	Federal Emergency Management Agency
HDPE	High Density Polyethylene
HDS	Hydraulic Design Series
HEC	Hydraulic Engineering Circular or Hydrologic Engineering Center
HERCP	Horizontal Elliptical Reinforced Concrete Pipe
HGL	Hydraulic Grade Line
LOMR	Letter of Map Revision
MAJOR	100-Year Storm Event
MINOR	5-Year Storm Event
NDEP	Nevada Division of Environmental Protection
NDOT	Nevada Department of Transportation
NFIP	National Flood Insurance Program

NOAA	National Oceanic and Atmospheric Administration
NPS	Non-point Source
NPDES	National Pollutant Discharge Elimination System
NRS	Nevada Revised Statutes
NWS	National Weather Service
PE	Professional Engineer Licensed by the State of Nevada
PMF	Probable Maximum Flood
PVC	Polyvinyl Chloride
RCBC	Reinforced Concrete Box Culvert
RCP	Reinforced Concrete Pipe
RGF	Regional Growth Factor
ROW	Right-of-Way
SCS	Soil Conservation Service
SSPFS	Southwest Semiarid Precipitation Frequency Study
SM	Square Miles
SPP	Structural Plate Pipe
SWPPP	Storm Water Pollution Prevention Plan
TR	Technical Release
TAC	Technical Advisory Committee
TRC	Technical Review Committee
USACE	United States Army Corps of Engineers
USBR	United States Bureau of Reclamation
USGS	United States Geological Survey
USLE	Universal Soil Loss Equation

SECTION 300 - DRAINAGE POLICY

TABLE OF CONTENTS

	<u>Page</u>
301 STATUTORY AUTHORITY	301
302 BASIC PRINCIPLES	302
302.1 DRAINAGE PLANNING AND REQUIRED SPACE	302
302.2 MULTI-PURPOSE RESOURCE	303
302.3 WATER RIGHTS	303
302.4 JURISDICTIONAL COOPERATION	303
303 REGIONAL AND LOCAL PLANNING.....	303
303.1 REASONABLE USE RULE	303
303.2 REGIONAL MASTER PLANNING.....	304
303.3 LOCAL MASTER PLANNING.....	304
303.4 DRAINAGE IMPROVEMENTS	304
303.5 DRAINAGE PLANNING SUBMITTAL AND REVIEW.....	305
303.6 FLOOD PLAIN MANAGEMENT.....	305
303.7 STORM RUNOFF DETENTION.....	306
303.8 STORM RUNOFF RETENTION.....	307
303.9 WATER QUALITY AND CONSTRUCTION ACTIVITIES.....	307
303.10 DRAINAGE FACILITIES MAINTENANCE	308
304 TECHNICAL CRITERIA	308
304.1 STORM WATER MANAGEMENT TECHNOLOGY.....	308
304.2 DESIGN STORM EVENTS	309
304.3 STORM RUNOFF DETERMINATION	310
304.4 STREETS.....	310
304.5 CULVERTS AND BRIDGES	311
304.6 FLOODPROOFING	312
304.7 ALLUVIAL FANS	312
305 IRRIGATION FACILITIES.....	312
305.1 DRAINAGE INTERACTION.....	312
305.2 IRRIGATION DITCHES.....	312
306 PRESERVATION OF NATURAL DRAINAGEWAYS.....	313

SECTION 300 DRAINAGE POLICY

301 STATUTORY AUTHORITY

In urban areas it is necessary to provide an adequate drainage system in order to preserve and promote the public health, safety, welfare, and economic well being of the region. Drainage is a regional feature that affects all governmental jurisdictions and all parcels of property. This characteristic of drainage requires coordination between different entities and cooperation from both the public and private sectors.

NRS 278.026 to 278.029, inclusive, have allowed in Washoe County the creation of the Truckee Meadows Regional Planning Commission and a Regional Governing Board. The Regional Planning Commission shall develop a comprehensive regional plan that includes, among other things, flood control facilities. The Regional Planning Commission may designate certain areas in the comprehensive regional plan as joint planning areas, thus allowing the County and the affected cities to jointly adopt a master plan for the areas so designated. The Truckee Meadows Regional Planning Commission has developed the Truckee Meadows Regional Plan. This plan has been adopted by the Regional Planning Governing Board.

Chapter 531 of the Statutes of Nevada 2007 created the Western Regional Water Commission (WRWC) and the Northern Nevada Water Planning Commission (NNWPC). The NNWPC is responsible for developing and updating the Comprehensive Regional Water Management Plan (Plan). The Plan provides for the region's current and future water supply, water quality, wastewater, storm water drainage, and flood control needs. The Plan covers an area of about 1,200 square miles of Southern Washoe County and includes the Cities of Reno and Sparks. This Manual provides the technical basis for implementation of the storm water drainage and flood control aspects of the Plan. The Jurisdictional Entities are also subject to local requirements in addition to this Manual, as outlined in the following table.

Table 301 - Pertinent Drainage Codes for Each of the Jurisdictional Entities

Jurisdiction	Reference	Entitled	Description
Unincorporated Washoe County	110 Development Code, Article 416	Flood Hazards	FEMA flood requirements
Unincorporated Washoe County	110 Development Code, Article 418	Significant Hydrologic Resources	Establishes setbacks from select waterways and regulates the uses in those setbacks.
Unincorporated Washoe County	110 Development Code, Article 420	Storm Drainage Standards	Current policies and technical design criteria
Unincorporated Washoe County	Ordinance 1223	Storm Water Discharge Ordinance	Regulates storm water discharge procedures
City of Reno	12.04.010* Article VI of the Reno Administrative Code	Standard Specifications for Public Works Construction	Adopts the "Standard Specifications for Public Works Construction" published by the RTC (a.k.a. "The Orange Book")

Jurisdiction	Reference	Entitled	Description
City of Reno	12.16* Article IV of the Reno Administrative Code	Storm Water Management and Discharge Control	Regulates storm water discharge procedures
City of Reno	18.12.701** Article VII of the Land Development Code	Streets	Adoption of "City of Reno Public Works Design Manual" which contains current storm drainage policies and technical design criteria in Chapter 2
City of Reno	18.12.1701** Article XVII of the Land Development Code	Flood Hazard Areas	FEMA Flood Requirements
City of Reno	18.12.1801** Article XVIII of the Land Development Code	Wetlands and Stream Environment Protection Standards	Establishes regulations pertaining to wetlands and stream environments
City of Reno	18.12.1901** Article XIX of the Land Development Code	Drainage Way Protection Standards	Establishes setbacks from select waterways and regulates the uses in those setbacks
City of Sparks	Sparks Municipal Code, Title 15, Chapter 15.11	Flood Plain Management	FEMA Flood Requirements
City of Sparks	Sparks Municipal Code, Title 17, Chapter 17.16, Section 17.16.140	Drainage	Subdivision drainage requirements

* All 12.XX.XXX items of the Reno Administrative Code fall under "Title 12 Public Works and Utilities".
 **All 18.XX.XXX items of the Reno Administrative Code fall under "Title 18 Annexation and Land Development" and are referred to as "Land Development Code".

302 BASIC PRINCIPLES

When planning drainage facilities, certain underlying principles provide direction for the effort. These principles are made operational through a set of policy statements. The application of the policy is in turn facilitated by technical criteria and data. When considered in a comprehensive manner, on a regional and local level with public and private involvement, drainage facilities can be provided in developing areas in a manner that will provide the flood protection required by the governing policy.

302.1 DRAINAGE PLANNING AND REQUIRED SPACE

The storm water drainage system is an integral part of the total urbanization process. The planning of drainage facilities must be included in the urbanization process. The first step is to include drainage planning with all regional and local development master plans.

Drainage systems require space to accommodate their conveyance and storage functions. When the space requirements are considered, the provision for adequate drainage becomes a competing use for space along with other land uses. If adequate provision is not made in a land use plan for the drainage requirements, storm water runoff will conflict with other land uses and will result in water damages, and will impair or even disrupt the functioning of other urban systems.

THE POLICY OF THE JURISDICTIONAL ENTITIES SHALL BE TO CONSIDER STORM WATER DRAINAGE AN INTEGRAL PART OF THE OVERALL URBAN SYSTEM, AND REQUIRE THAT ALL DEVELOPMENTS PROVIDE STORM DRAINAGE PLANNING THAT INCLUDES THE ALLOCATION OF SPACE FOR DRAINAGE FACILITY CONSTRUCTION AND MAINTENANCE, WHICH MAY ENTAIL THE DEDICATION OF RIGHT-OF-WAY AND/OR EASEMENTS.

302.2 MULTI-PURPOSE RESOURCE

Storm water runoff is an integral part of Washoe County's surface and groundwater resources. This resource has the potential of being utilized for different beneficial uses. These uses, however, must be compatible with adjacent land uses and applicable State Water Laws.

THE POLICY OF THE JURISDICTIONAL ENTITIES SHALL BE TO CONSIDER STORM WATER RUNOFF AS AN INTEGRAL PART OF THE AREA'S SURFACE AND GROUNDWATER RESOURCES AND RECOGNIZE ITS POTENTIAL FOR OTHER USES.

302.3 WATER RIGHTS

A drainage design must be planned and constructed with proper recognition given to the existing vested water rights and applicable water laws. When the drainage system interferes with existing water rights, the value and use of the water rights are affected.

THE POLICY OF THE JURISDICTIONAL ENTITIES SHALL BE TO RECOGNIZE THE EXISTENCE OF VESTED WATER RIGHTS AND TO ABIDE BY ANY AGREEMENTS IN WHICH THE JURISDICTIONAL ENTITY HAS RELINQUISHED ITS RIGHTS TO APPROPRIATE UNAPPROPRIATED WATER IN THE TRUCKEE RIVER BASIN.

302.4 JURISDICTIONAL COOPERATION

Since drainage considerations and problems are regional in nature, and do not respect jurisdictional boundaries, drainage planning must emphasize regional jurisdictional cooperation, unified standards, and similar drainage requirements in accomplishing the goals.

THE POLICY OF THE JURISDICTIONAL ENTITIES SHALL BE TO PURSUE A JURISDICTIONALLY UNIFIED DRAINAGE EFFORT TO PROMOTE AN INTEGRATED COMPREHENSIVE REGIONAL DRAINAGE PLAN.

303 REGIONAL AND LOCAL PLANNING

303.1 REASONABLE USE RULE

Drainage Law (Section 400 of this Manual) recognizes that downstream properties should not be unreasonably burdened with increased flow rates or unreasonable changes in manner of flow from upstream properties. The law also recognizes that drainage problems should not be transferred from one basin to another (basin transfers). However, drainage law also acknowledges that downstream properties cannot block natural runoff through their site and must accept runoff from upstream properties.

The "Reasonable Use Rule" is defined for drainage planning purposes as permitting the use of an economic and hydraulically efficient drainage system which is demonstrated not to adversely impact

adjacent and downstream properties within reason. This "Reasonable Use of Drainage" therefore allows development to occur while preserving the rights of adjacent property owners.

THE POLICY OF THE JURISDICTIONAL ENTITIES REGARDING THE "REASONABLE USE RULE" IS TO:

- 1. LIMIT THE RATE OF FLOW FROM DEVELOPING PROPERTIES TO THEIR PRE-DEVELOPMENT CONDITION FLOW RATES. THE JURISDICTIONAL ENTITY WOULD CONSIDER PLANS TO ACCOMMODATE THIS LIMITATION BY CONSTRUCTION OF LOCAL ON-SITE FACILITIES OR REGIONAL FACILITIES.**
- 2. TRANSITION FLOWS FROM DEVELOPING PROPERTIES TO THEIR PREDEVELOPMENT PATHS ON DOWNSTREAM PROPERTIES.**
- 3. MAINTAIN FLOWS IN THEIR NATURAL DRAINAGE BASINS.**

303.2 REGIONAL MASTER PLANNING

Washoe County has prepared a conceptual level Flood Control Master Plan. The next phase of the flood control master planning is to develop a detailed regional master plan, which will be adopted by the jurisdictional entities. All regional facilities, with or without a regional master plan, must be so designated by the jurisdictional entities.

THE POLICY OF THE JURISDICTIONAL ENTITIES SHALL BE TO DEVELOP AND ADOPT A REGIONAL FLOOD CONTROL MASTER PLAN, AND REGULATE IN A MANNER CONSISTENT WITH SUCH PLAN. THE REGIONAL PLAN SHALL INCLUDE PLANNING COMPLETED OR UNDERTAKEN BY THE JURISDICTIONAL ENTITIES AND DEVELOPERS. THE JURISDICTIONAL ENTITIES RECOGNIZE THE NEED TO REVIEW THE PLAN ANNUALLY AND UPDATE IT NOT LESS THAN EVERY 5 YEARS.

303.3 LOCAL MASTER PLANNING

Local Flood Control Facilities, as planned by the jurisdictional entities and developers, are an integral part of the total drainage system required to preserve and promote the general health, welfare, and economic well being of the area. **Any facility that generates benefits exclusively to the benefit of the local entity, or is not designated as a regional facility, shall be considered a local facility.**

THE POLICY OF THE JURISDICTIONAL ENTITIES SHALL BE TO DEVELOP FLOOD CONTROL FACILITIES WHICH ARE COMPATIBLE WITH THE WASHOE COUNTY REGIONAL FLOOD CONTROL MASTER PLAN.

303.4 DRAINAGE IMPROVEMENTS

Drainage improvements include those in the Washoe County Regional Flood Control Master Plan, new development drainage plans, and basin management plans. The Local Flood Control Facilities consist of curb and gutter, inlets and storm sewers, culverts, bridges, swales, ditches, channels, detention areas, and other drainage facilities required to convey the minor and major storm runoff to its ultimate major drainageway. These Local Flood Control Facilities are further defined as on-site or off-site (private) facilities and off-site (public) facilities. The on-site and off-site (private) facilities serve a specific development and are privately owned and maintained. The off-site (public) facilities are facilities which are dedicated to the public and are publicly maintained. These off-site (public) facilities may actually be constructed within the specific development to pass through flow from upstream properties. The major drainageway Flood Control Facilities consist of channels, storm

drains, bridges, detention areas, and other facilities which carry runoff from on-site and off-site facilities to an ultimate outfall location. The management of all privately maintained facilities must be acceptable to the jurisdictional entities.

When capital improvement plans identify that drainage improvements are justified, NRS 278B provides the mechanism for funding the required improvements. The funding for public improvements which serve only a single development shall be obtained from that development. This funding is provided by having these public improvements designed and constructed by the subject development.

THE POLICY OF THE JURISDICTIONAL ENTITIES SHALL BE THAT ALL NEW DEVELOPMENT PLAN, DESIGN, CONSTRUCT, AND MAINTAIN THE REQUIRED DRAINAGE IMPROVEMENTS IN ACCORDANCE WITH THE FOLLOWING:

1. **Local On-Site and Off-Site (Private) Flood Control Facilities.**
2. **Local Off-Site (Public) Flood Control Facilities are required to provide adequate conveyance capacity from the Local On-Site (Private) Flood Control Facilities to the Regional Flood Control Facilities or for pass through of upstream off-site runoff. Oversizing of the Local (Public) Off-Site Flood Control Facilities to accommodate future development may be required by the jurisdictional entities. The jurisdictional entities may require payment to a local (Public) off-site facilities fund in lieu of construction of these facilities by the developer.**
3. **Regional Flood Control Facilities passing through or directly adjacent to the subject development. The jurisdictional entities may participate in funding of these regional improvements if the improvements are designed, constructed and implemented by the jurisdictional entities, and in accordance with the Regional Master Plan and this Manual.**
4. **Regional facilities shall be designed to accommodate multi-purpose uses.**
5. **Maintenance shall be in accordance with Section 303.10 of this Manual.**

303.5 DRAINAGE PLANNING SUBMITTAL AND REVIEW

Review and acceptance of drainage plans, studies, and construction drawings and specifications by the jurisdictional entities is required to obtain a final drainage system which is consistent and integrated in analysis, design, and level of protection. The degree of review depends on the complexity of the drainage improvement under consideration.

THE POLICY OF THE JURISDICTIONAL ENTITIES IS TO REQUIRE THAT ALL DRAINAGE PLANS, STUDIES, AND CONSTRUCTION DOCUMENTS BE SUBMITTED FOR REVIEW AND ACCEPTANCE BY THE APPROPRIATE JURISDICTIONAL ENTITY AND BE CONSISTENT WITH ANY APPLICABLE BASIN MANAGEMENT PLAN AND REGIONAL MASTER PLAN.

State Agencies shall consider and, when applicable, comply with the jurisdictional entities' Master Plan when planning and designing their flood control facilities.

303.6 FLOOD PLAIN MANAGEMENT

The jurisdictional entities' appropriate local codes establish guidelines and requirements for development of properties within areas subject to flooding. The purpose of flood plain management is

to provide the guidance, conditions, and restrictions for development in flood plain areas while protecting the public's health, safety, welfare, and property from danger and damage.

To provide impetus for proper flood plain management, the United States government, acting through the Federal Emergency Management Agency's (FEMA) National Flood Insurance Program (NFIP), has established regulations for development in flood plain areas. Compliance with these regulations allows property owners to obtain lower cost flood insurance premiums and/or eliminates the requirement for the owner to obtain flood insurance as a condition for obtaining government supported loans. Therefore, there is a benefit to Washoe County population for remaining in compliance with the NFIP's regulations, and further allows the jurisdictional entities to maintain eligibility for federal disaster relief funds.

THE POLICY OF THE JURISDICTIONAL ENTITIES SHALL BE TO REGULATE FLOOD PLAINS IN ACCORDANCE WITH THE PROVISIONS OF THE JURISDICTIONAL ENTITIES' DEVELOPMENT CODE AND THE REGULATIONS OF THE NATIONAL FLOOD INSURANCE PROGRAM (NFIP).

303.7 STORM RUNOFF DETENTION

Detention is considered a viable method to reduce urban drainage costs. Temporarily detaining storm runoff can significantly reduce downstream flood hazards as well as reduce pipe and channel sizes in urban areas. Storage also provides for sediment and debris collection, which helps to maintain water quality in downstream channels and streams. However, detention may not be necessary where downstream drainage facilities in their original or previously improved condition are adequate in capacity to carry flows from fully developed upstream areas without negatively impacting downstream properties.

THE POLICY OF THE JURISDICTIONAL ENTITIES SHALL BE TO REQUIRE LOCAL DETENTION STORAGE FOR NEW DEVELOPMENTS TO LIMIT PEAK FLOWS FROM BOTH A 5-YEAR STORM (Q_5) AND A 100-YEAR STORM (Q_{100}) TO THEIR PRE-DEVELOPMENT CONDITIONS.

THE CAPACITY OF DOWNSTREAM CONVEYANCE SYSTEMS SHALL BE ANALYZED IN ACCORDANCE WITH THIS MANUAL AND SHALL BE BASED ON RUNOFF FROM THE DEVELOPMENT AS FULLY IMPROVED. LOCAL DETENTION IS ALSO REQUIRED WHEN DESIGNATED IN MASTER PLANS TO REDUCE THE PEAK RUNOFF RATE IN REGIONAL FACILITIES.

EXEMPTIONS TO THE DETENTION POLICY MAY BE GRANTED BY THE JURISDICTIONAL ENTITIES FOR THE FOLLOWING:

- 1. DEVELOPMENTS OF LESS THAN 2 ACRES WITH AN IMPERVIOUS DENSITY OF 50% OR LESS.**
- 2. ADDITIONS TO BUILDINGS PROVIDED THE IMPERVIOUS DENSITY OF THE ENTIRE PROPERTY DOES NOT INCREASE BY MORE THAN 10% OR THE TOTAL IMPERVIOUS AREA DOES NOT INCREASE BY MORE THAN ONE ACRE, WHICHEVER IS LESS.**
- 3. DEVELOPMENTS WHICH DISCHARGE DIRECTLY TO A REGIONAL FLOOD CONTROL FACILITY PROVIDED THE REGIONAL FACILITY IS COMPLETED PER THE ADOPTED MASTER PLAN.**
- 4. LOCATIONS WHERE A LOCAL DETENTION FACILITY IS PLANNED TO SERVE SEVERAL DEVELOPMENTS. FOR THIS EXEMPTION, THE**

JURISDICTIONAL ENTITY MAY REQUIRE PAYMENT TO A LOCAL DETENTION FACILITIES FUND IN LIEU OF CONSTRUCTION OF THE DETENTION FACILITY BY THE DEVELOPER.

5. **UPGRADING OF DOWNSTREAM FACILITIES TO ACCOMMODATE THE INCREASED FLOW RATE.**
6. **WHERE THE DOWNSTREAM CAPACITIES ARE ADEQUATE TO CARRY UP TO 100-YEAR FLOWS.**
7. **CASES THAT PRESENT AN ADVERSE IMPACT TO THE CRITICAL FLOOD POOL, OR TO EXISTING OR PROPOSED DOWNSTREAM REGIONAL CONVEYANCE FACILITIES.**

ALL EXEMPTIONS ARE SUBJECT TO APPROVAL BY THE JURISDICTIONAL ENTITIES.

303.8 STORM RUNOFF RETENTION

Storm Runoff retention has been used to eliminate the need for constructing outlet structures and for ease of construction. However, problems with past retention basins from soil expansion, siltation, and lack of infiltration capacity have created a nuisance to the general public. Further, runoff retention has the potential of depriving downstream water rights of their legal right to the retained water. Each potential site will have different site constraints which will require individual evaluation of suitability for retention purposes at said site.

THE POLICY OF THE JURISDICTIONAL ENTITIES SHALL BE TO MINIMIZE THE USE OF RETENTION FACILITIES, EXCEPT WHERE SIGNIFICANT ENVIRONMENTAL, RECREATIONAL OR RECHARGE BENEFITS ARE APPARENT. STANDARDS FOR DESIGN OF SUCH FACILITIES WILL BE ESTABLISHED BY THE JURISDICTIONAL ENTITIES ON A SITE BY SITE BASIS.

303.9 WATER QUALITY AND CONSTRUCTION ACTIVITIES

A number of studies by the Environmental Protection Agency (EPA) and others have shown that site disturbances due to construction and resulting urbanization decreases the quality of runoff from the natural conditions. The jurisdictional entities recognize that drainage facilities which enhance water quality may be needed in the future; and measures, methods of operation or construction practices are needed to control degradation of water quality. The Nevada Division of Environmental Protection (NDEP) in conjunction with the Jurisdictional Entities has jurisdiction over construction project storm water pollution prevention plans for sites that are one acre and larger, while the local jurisdiction has jurisdiction over sites that are smaller than one acre.

THE POLICY OF THE JURISDICTIONAL ENTITIES SHALL BE TO REQUIRE THE DESIGN OF DRAINAGE FACILITIES AND OTHER MEASURES WHICH ENHANCE THE QUALITY OF STORM RUNOFF. THESE STORM WATER QUALITY IMPROVEMENTS SHALL BE DESIGNED BY FOLLOWING THE GUIDELINES AND REQUIREMENTS OF THE LATEST EDITION OF THE "TRUCKEE MEADOWS STRUCTURAL CONTROLS DESIGN MANUAL". THE JURISDICTIONAL ENTITIES AND STATE NPDES STORM WATER DISCHARGE PERMIT PROGRAMS REQUIRE THAT STORM WATER POLLUTION PREVENTION PLANS (SWPPP) FOR CONSTRUCTION ACTIVITIES BE PREPARED AND IMPLEMENTED. THESE PLANS SHALL BE PREPARED USING THE LATEST EDITION OF THE "TRUCKEE MEADOWS CONSTRUCTION SITE BEST MANAGEMENT PRACTICES HANDBOOK".

303.10 DRAINAGE FACILITIES MAINTENANCE

An important part of all storm drainage facilities is the continued maintenance of the facilities to ensure they will function as designed. Maintenance of detention facilities involves removal of debris and sediment. Such tasks are necessary to preclude the facility from becoming a health hazard and to retain the effectiveness of the detention basin. Sediment and debris must also be periodically removed from channels and storm sewers. Trash rack and street inlets must be regularly cleared of debris to maintain system capacity. Channel bank erosion, damage to drop structures, crushing of pipe inlets and outlets, and deterioration to the facilities must be repaired to avoid reduced conveyance capability, unsightliness, and ultimate failure.

THE POLICY OF THE JURISDICTIONAL ENTITIES SHALL BE TO REQUIRE THAT ALL DRAINAGE FACILITIES BE DESIGNED TO MINIMIZE FACILITY MAINTENANCE AS WELL AS TO PROVIDE EASE OF MAINTENANCE AND INCLUDE MAINTENANCE ACCESS TO THE ENTIRE DRAINAGE FACILITY. A MINIMUM 15 FOOT WIDE DRAINAGE EASEMENT SHALL BE PROVIDED FOR ALL PUBLICLY AND PRIVATELY MAINTAINED DRAINAGE FACILITIES.

THE POLICY OF THE JURISDICTIONAL ENTITIES IS TO REQUIRE THE PROPERTY OWNER OR DEVELOPER TO PROVIDE AN ACCEPTABLE MAINTENANCE PLAN AND PERPETUAL FUNDING FOR MAINTENANCE OF ALL PRIVATELY OWNED OR OTHER NON-JURISDICTIONAL MAINTAINED ON-SITE DETENTION BASINS AS WELL AS OFF-SITE DRAINAGE FACILITIES INCLUDING, BUT NOT LIMITED TO, INLETS, PIPES, CHANNELS, AND DETENTION BASINS, UNLESS MODIFIED BY SEPARATE AGREEMENT. SHOULD THE PROPERTY OWNER OR DEVELOPER FAIL TO ADEQUATELY MAINTAIN SAID FACILITIES, THE JURISDICTIONAL ENTITY SHALL BE GIVEN THE RIGHT TO ENTER SAID PROPERTY, UPON PROPER NOTICE, FOR THE PURPOSES OF MAINTENANCE. ALL SUCH MAINTENANCE COSTS, NOT COVERED BY THE FUNDING PROVIDED, SHALL BE ASSESSED AGAINST THE OWNER. THE JURISDICTIONAL ENTITIES SHALL APPROVE THE TYPE OF FUNDING, MAINTENANCE AND THE SCHEDULES ASSOCIATED WITH SUCH WORK.

THE POLICY OF THE JURISDICTIONAL ENTITIES SHALL BE TO ENSURE THAT ALL REGIONAL OR LOCAL FLOOD CONTROL FACILITIES ARE PROPERLY MAINTAINED, WHETHER THEY ARE PUBLICLY OR PRIVATELY OWNED. THE JURISDICTIONAL ENTITIES MAY REQUIRE THAT A FUNDING MECHANISM BE ESTABLISHED. IN ADDITION, THE JURISDICTIONAL ENTITIES MAY HAVE SPECIFIC DESIGN REQUIREMENTS FOR PROJECTS OR OTHER WORK AFFECTING REGIONAL OR LOCAL FLOOD CONTROL FACILITIES WHERE SUCH FACILITIES:

- 1. WILL BE UPGRADED OR MODIFIED AS PART OF A PROJECT,**
- 2. WILL BE SUBJECT TO CHANGES IN THE VOLUME OR NATURE OF FLOWS PRESENT, INCLUDING SEDIMENT, DUE TO A PROJECT,**
- 3. ARE DETERMINED BY THE JURISDICTIONAL ENTITY TO BE SIGNIFICANT TO A PROJECT.**

304 TECHNICAL CRITERIA

304.1 STORM WATER MANAGEMENT TECHNOLOGY

The information presented in this Manual represents the current state-of-the-art in storm water management planning and design. However, the dynamic nature of storm water runoff technology, information, and criteria will continue to advance the state-of-the-art of storm water management.

Therefore, this Manual should be periodically updated to account for advances made in the storm water management field.

THE POLICY OF THE JURISDICTIONAL ENTITIES SHALL BE TO KEEP ABREAST OF THE STATE-OF-THE-ART IN STORM WATER MANAGEMENT AND AMEND AND/OR MODIFY THESE CRITERIA AS NEW TECHNOLOGY IS DEVELOPED AND EXPERIENCE GAINED IN THE USE OF THESE CRITERIA.

304.2 DESIGN STORM EVENTS

The jurisdictional entities have determined that drainage facilities should, as a minimum, be designed based on runoff from the Minor storm event and a Major storm event.

THE POLICY OF THE JURISDICTIONAL ENTITIES SHALL BE TO REQUIRE THAT ALL NEW DEVELOPMENT INCLUDE, AS A MINIMUM, THE PLANNING, DESIGN, AND CONSTRUCTION OF DRAINAGE FACILITIES BASED ON THE FOLLOWING CRITERIA:

TYPE OF FACILITY	DESIGN CRITERIA	USE OF RATIONAL METHOD ALLOWED?
DETENTION	MAINTAIN PREDEVELOPMENT CONDITIONS FOR MAJOR AND MINOR STORM: ADDRESS OVERFLOW. SEE 303.7	
LOCAL STORM DRAIN	MINOR STORM - GRAVITY FLOW. MAJOR STORM – PRESSURE FLOW. SEE 902.1	YES
REGIONAL/FLOOD-CONTROL STORM DRAIN OR SYSTEMS	MAJOR STORM. SEE 901	CONSULT JURISDICTIONAL ENTITY.
CONVEYANCE IN STREET SECTION CHANNELS	MAJOR AND MINOR STORM. SEE 304.4	YES
CULVERTS AND BRIDGES	MAJOR STORM. MAJOR STORM; POSSIBLE OVERFLOW SECTION. SEE 304.5	YES CULVERTS: YES BRIDGES: CONSULT JURISDICTIONAL ENTITY.
CLOSED BASIN	SEE 709.2	NOT FOR VOLUME CALCULATIONS

THE MINOR STORM EVENT SHALL HAVE A RECURRENCE INTERVAL OF 5 YEARS, WHILE THE MAJOR STORM EVENT SHALL HAVE A RECURRENCE INTERVAL OF 100 YEARS.

304.3 STORM RUNOFF DETERMINATION

The storm runoff peak, volume, and timing provide the basis for all planning, design, and construction of drainage facilities. The best method for determining storm runoff is to measure the runoff from a flood with a known intensity and recurrence interval. Since this approach is not practical in the Washoe County area due to lack of availability of long term rainfall/runoff data, various analytical methods have been developed which predict the storm runoff from preselected hydrologic conditions (independent of chance). These methods are referred to as deterministic models.

THE POLICY OF THE JURISDICTIONAL ENTITIES SHALL BE TO REQUIRE THE DETERMINATION OF STORM RUNOFF (RATES AND VOLUMES) IN ACCORDANCE WITH THE FOLLOWING:

CONTRIBUTING BASIN AREA	COMPUTATION PROCEDURE
A ≤ 100 ACRES	RATIONAL FORMULA, SCS HEC-1 OR HEC-HMS (SCS UNIT HYDROGRAPH OR KINEMATIC WAVE)
10 S.M. > A > 100 ACRES	SCS HEC-1 OR HEC-HMS (SCS UNIT HYDROGRAPH OR KINEMATIC WAVE)
A > 10 S.M.	SCS HEC-1 OR HEC-HMS WITH COMPARISON TO PEAK FLOWS GENERATED BY A STATISTICAL ANALYSIS OR RUNOFF RECORDS WITHIN THE SAME OR ADJACENT DRAINAGE BASIN

ALL STORM DRAIN PIPE SYSTEMS WITH A CONTRIBUTING AREA OF ≤ 100 ACRES SHALL BE DESIGNED USING THE RATIONAL FORMULA.

ANY EXCEPTIONS TO THESE PROCEDURES MUST BE APPROVED BY THE PUBLIC WORKS DEPARTMENT OF THE APPROPRIATE JURISDICTIONAL ENTITY PRIOR TO THEIR SUBMITTAL TO THE LOCAL JURISDICTION.

304.4 STREETS

The use of streets to convey storm runoff interferes with the primary function of the street for transportation purposes. Streets are, however, an important component in the storm drainage system due to their large storm runoff carrying capacity obtained for little or no drainage related costs. In order to balance these two competing street uses, limits on the street carrying capacity are required based on the classification of the street related to emergency usage during flood events.

THE POLICY OF THE JURISDICTIONAL ENTITIES SHALL BE TO LIMIT FLOODING OF STREETS TO THE FOLLOWING:

1. **MINOR ON-SITE STORM EVENT (Q₅)**
 - A. **Maximum velocity times depth will be 6 ft²/sec (Abt, S.R., et al and AWRA, 1989).**
 - B. **Runoff in excess of street capacity shall be piped.**
 - C. **Maximum limits of street inundation:**

Local	12 foot width dry centered
Collector	18 foot width dry centered

Arterial 48 foot width dry centered
Dry widths exclude all medians and center left turn lanes

2. MAJOR ON-SITE STORM EVENT (Q₁₀₀)

- A. Contained within street right-of-way.**
 - B. Maximum velocity times depth will be 8 ft²/sec (Abt, S.R., et al, 1989)**
 - C. Maximum depth will be 1 foot at the gutter flowline.**
 - D. Maximum limits of street inundation:**

Local	Street flooded
Collector	1 lane (12 feet) dry centered
Arterial	1 lane (12 feet) dry each direction 24 foot width dry centered
- Dry widths exclude all medians and center left turn lanes**

3. OFF-SITE MINOR AND MAJOR STORM EVENTS SHALL BE DIVERTED

- A. Diverted around or piped/channeled through development.**
- B. The construction in special flood hazard areas as defined by NFIP and areas of interim delineation shall be completed in accordance with the Local Jurisdictional Development Code.**
- C. Flows must return to the predevelopment drainage path after exiting development.**

4. STREETS WHICH INTERSECT STATE HIGHWAYS: Where local, collector, or arterial streets intersect State Highways, the criteria of the Nevada Department of Transportation shall be followed for design of storm drains and inlets at said intersections.

304.5 CULVERTS AND BRIDGES

Culverts and bridges are required where natural or manmade channels are crossed by roads and streets. The amount of channel flow which crosses over the road should be minimized to protect the road embankment and pavement from erosion damage as well as to protect vehicles and pedestrians from dangerous flow depths and velocities.

THE POLICY OF THE JURISDICTIONAL ENTITIES SHALL BE TO REQUIRE CULVERT / BRIDGE CROSSINGS OF STREETS WITHIN THE FOLLOWING LIMITATIONS:

<u>Right-Of-Way Width</u>	<u>Minimum Capacity (Recurrence Interval)</u>
Major and Minor Arterial Highways/Greater than or equal to 80 feet	100-year (No Overflow)
Collector and Local Streets/Less than 80 feet	100-Year (See Note)

Note: A dipped overflow section may be allowed by the jurisdictional entities if the maximum velocity does not exceed 6 feet per second and the maximum depth does not exceed 0.5 feet at the street crown. As a minimum, where the existing channel is incapable of passing the 100-year flow, the culvert or bridge shall pass the existing channel capacity.

304.6 FLOODPROOFING

Floodproofing can be defined as those measures which reduce the potential for flood damages to properties within a flood plain. The floodproofing measures can range from elevating structures to intentional flooding of non-critical building spaces (i.e., basement) to minimize structural damages.

THE POLICY OF THE JURISDICTIONAL ENTITIES SHALL BE TO ALLOW THE FLOODPROOFING OF EXISTING COMMERCIAL STRUCTURES LOCATED WITHIN A DESIGNATED FLOOD PLAIN AREA WHICH ARE NOT BUILT IN CONFORMANCE TO THE ADOPTED FLOOD PLAIN REGULATIONS. ALL SUCH FLOODPROOFING SHALL COMPLY WITH PROVISIONS OF THE JURISDICTIONAL ENTITY CODE AND FEMA FLOODPROOFING REGULATIONS.

304.7 ALLUVIAL FANS

Alluvial Fans consisting of sand and fine sediment are subject to radical changes in shape, direction, depth, and flow carrying capacity during storm events. These changes increase the potential flood hazards of developing on alluvial fan areas and require additional analysis and design to provide safe and effective facilities to accommodate these hazards.

THE POLICY OF THE JURISDICTIONAL ENTITIES SHALL BE TO REQUIRE DEVELOPMENT ON ACTIVE ALLUVIAL FANS TO COMPLY WITH THE JURISDICTIONAL ENTITY CODE.

305 IRRIGATION FACILITIES

305.1 DRAINAGE INTERACTION

There are a number of irrigation ditches and reservoirs in the Washoe County area. These ditches and reservoirs have historically intercepted the storm runoff from the rural and agricultural type basins, generally without major problems. With urbanization of the basins, however, the storm runoff has increased in rate, quantity and frequency, as well as changing in water quality. In urbanized areas, the irrigation facilities can no longer be utilized indiscriminately to convey storm runoff, and therefore policies must be established to achieve compatibility between urbanization and the irrigation facilities.

In evaluating the interaction of irrigation ditches with a major drainageway for the purpose of basin delineation, the ditch should not be utilized as a basin boundary due to the limited flow capacity of the ditch. The ditches will generally be flowing full or near full during major storms and, therefore, the tributary basin runoff would flow across the ditch.

THE POLICY OF THE JURISDICTIONAL ENTITIES SHALL BE TO REQUIRE DRAINAGE ANALYSIS TO ASSUME THAT AN IRRIGATION DITCH DOES NOT INTERCEPT THE STORM RUNOFF FROM THE UPPER BASIN AND THAT THE UPPER BASIN IS TRIBUTARY TO THE BASIN AREA DOWNSTREAM OF THE DITCH.

305.2 IRRIGATION DITCHES

Irrigation ditches are designed with flat slopes and limited carrying capacity, which decreases in the downstream direction. As a general rule, irrigation ditches cannot be used as an outfall point for the storm drainage system because of these physical limitations. In addition, certain ditches are abandoned after urbanization and therefore could not be successfully utilized for storm drainage. Therefore, post-development sheet flow to an irrigation ditch shall not exceed pre-development sheet flow.

THE POLICY OF THE JURISDICTIONAL ENTITIES IS TO PROHIBIT THE USE OF IRRIGATION DITCHES AS STORM DRAINAGE FACILITIES.

306 PRESERVATION OF NATURAL DRAINAGEWAYS

Natural drainageways are considered an important element that contributes to the image and livability in an urban environment. Their value extends beyond that of conveying flood water, to their use as trail and open space corridors, and to maintain natural vegetation and wildlife habitat to the greatest degree possible.

THE POLICY OF THE JURISDICTIONAL ENTITIES IS TO ENSURE THAT DEVELOPMENT OF PROPERTY SHALL NOT ADVERSELY AFFECT ANY NATURAL DRAINAGE FACILITY OR NATURAL WATER COURSE, AND SHALL BE SUBJECT TO THE FOLLOWING PROVISIONS:

- 1. Natural drainageways shall remain in as near to a natural state as is practicable, with any modification proposed, including any erosion mitigating measures, addressed in the Drainage Report and drainage plans; and**
- 2. When the flows, velocity or side slope as determined by the Drainage Report indicates a hazard, the applicant shall provide fencing in accordance with jurisdictional entity code.**

References

Abt, S.R., et al, 1989, Human Stability in a High Flood Hazard Zone, American Water Resources Association, Water Resources Bulletin, Vol. 25, No. 4, August 1989.

SECTION 400 - DRAINAGE LAW

TABLE OF CONTENTS

	<u>Page</u>
401 INTRODUCTION	401
402 HISTORICAL EVOLUTION OF SURFACE WATER DRAINAGE LAW.....	401
402.1 THE COMMON ENEMY DOCTRINE	401
402.2 CIVIL LAW RULE	402
402.3 REASONABLE USE RULE	402
403 NEVADA DRAINAGE LAW	403
403.1 CIVIL LAW RULE	403
403.2 REASONABLE USE RULE	404
403.3 SURFACE WATERS - PRIVATE DEVELOPMENT	406
404 SURFACE WATERS - GOVERNMENTAL ENTITY LIABILITY	410
404.1 SOVEREIGN IMMUNITY	410
404.2 NRS 41.032 - DISCRETIONARY IMMUNITY.....	411
404.3 NRS 41.033 - FAILURE TO INSPECT	412
404.4 LIMITATION OF TORT DAMAGE AWARDS	412
404.5 INVERSE CONDEMNATION -EMINENT DOMAIN.....	413

SECTION 400

DRAINAGE LAW

401 INTRODUCTION

The materials contained in this chapter are not intended to be an exhaustive or up-to-date presentation of each area of law which is discussed. The purpose is to familiarize the design professionals with these areas to enable them to better perform engineering duties and tasks. These materials should not be used in place of a consultation with an attorney and no liability is being assumed with respect to the use of these materials for such purpose.

An important lesson which has been learned in Southern Nevada is that water does not respect arbitrary jurisdictional boundaries. Water does not respect the various rights and liabilities of adjacent land owners as it flows through depressions, gullies, and washes. However, engineers are presented with the enormous task of attempting to control the drainage of water while at the same time maintaining the integrity of natural flow paths and existing legal relationships arising from land ownership. The goal of maintaining both natural flow paths and existing legal relationships is not easily achieved. However, this goal can be more easily achieved if the engineer is familiar with the basic legal framework against which legal relationships will be adjudicated.

This section discusses the historical evolution of water drainage law in Nevada. Unlike other states such as California and Colorado, there is not a great body of Nevada case law which discusses every identifiable issue with respect to water drainage law. There are many gray areas in Nevada law, but the engineer can avoid major legal obstacles by being more familiar with those cases which have been expressly decided by the Nevada Supreme Court. Relevant statutes will also be discussed.

402 HISTORICAL EVOLUTION OF SURFACE WATER DRAINAGE LAW

Prior to a specific discussion of Nevada law, it is important for the engineer to be aware of the development of the historical principles and theories involved in drainage law. There are three common early doctrines which were followed in the United States: the common enemy doctrine, civil law rule, and the rule of reasonable use. Each theory will be briefly examined prior to an in depth analysis of Nevada law.

402.1 THE COMMON ENEMY DOCTRINE

The common enemy doctrine is a harsh rule which is still followed in some states. The common enemy doctrine has not been specifically recognized by the Nevada Supreme Court.

Stated in its extreme form, the common enemy doctrine provides that as an incident to property use each landowner has an unqualified right, by operations on the land, to fight off surface waters as necessary without being required to take into account the consequences to other land owners, who have the duty and right to protect themselves as best they can (See, 93 ALR 3d 1193).

Surface water was thus regarded as a common enemy which each property owner could fight off or control by any means such as retention, diversion, repulsion or altered conveyance. Thus, there was no cause of action even if some injury occurred to the adjoining parcel.

All jurisdictions originally following this harsh rule have either modified the rule or adopted the civil law rule or reasonable use. Rule 5 **Water and Water Rights**, Sections 450.6.451 (RE Clark Ed. 1972).

As previously mentioned, the Nevada Supreme Court has not specifically recognized or adopted this theory.

402.2 CIVIL LAW RULE

Courts later recognized the rule of water drainage law which is basically diametrically opposed to the common enemy doctrine. The civil law rule recognizes a natural servitude for natural drainage between adjoining lands, so that the lower owner must accept the surface water which naturally drains onto its land, but on the other hand, the upper owner has no right to change the natural system of drainage to increase the burden on the lower parcel. This rule caused problems with allowing development because virtually almost any development has a tendency to increase the flow either in quantity or velocity. According to the civil law rule, if the quantity or velocity of water flow were increased, the natural flow on the downstream property would be changed and would be in violation of the civil law rule. Thus, with the evolution of drainage law the courts sought to modify the law to consider the competing interests of adjoining land owners and allocate the burden of risk associated with development.

The civil law rule analyzes drainage problems in terms of property law concepts such as servitudes and easements. It did not consider tort law analysis of what is "reasonable".

The Nevada Supreme Court specifically recognized the civil law rule as early as 1885 in the case of **Boyton v. Longley**, 19 Nev. 69, 6 Pac. 437 (1885). This case will be discussed in detail in the analysis of Nevada drainage law.

402.3 REASONABLE USE RULE

The rule of reasonable use was developed as an alternative between the civil law rule and the common enemy doctrine. The courts attempted to balance the hardships created in attempting to control surface waters and relevant factors in the relationship between the competing rights/liabilities of adjoining land owners. The rule was apparently developed to provide flexibility in avoiding harsh results which often occurred in applying both the common enemy doctrine and the civil law rule to various factual situations.

Under the reasonable use rule, a property owner can legally make reasonable use of its land, even though the flow of surface waters is altered and causes some harm to others. However, liability occurs when the property owners' harmful interference with the flow of surface water is "unreasonable". A balancing test is utilized to determine whether a landowner's use of his property is unreasonable. The analysis involves three basic questions: (1) Was there reasonable necessity for the property owner to alter the drainage to make use of his land? (2) Was the alteration done in a reasonable manner? (3) Does the utility of the actor's conduct reasonably outweigh the gravity of harm to others? See, Restatement Torts, 822-831, 833 (1939).

The Nevada Supreme Court has recognized consideration of at least five factors (see discussion on factors in Section 403.2) in determining whether a property owner's conduct was reasonable. As one can see from this analysis, it becomes very difficult to predict how a jury would rule in relation to any particular set of facts because the standard for determination is reasonableness, and each jury will have its own standard for determining reasonable conduct.

The reasonable use rule does not utilize property law concepts of servitude and easement. It substitutes a tort analysis of "reasonable" conduct. The positive aspect of this rule is that it accommodates development and allows for alterations of surface flow if done in a responsible manner. The negative aspect of this rule is the uncertainty created by the vague standard regarding "reasonable" conduct. One engineer's "reasonable" design for handling surface waters may be perceived by a different engineer in a court of law as "unreasonable".

403 NEVADA DRAINAGE LAW

The Supreme Court of Nevada initially adopted the civil law rule of drainage in 1885. The civil law rule was later changed when the Nevada Supreme Court adopted the reasonable use rule for surface water drainage in 1980. However, it is important for the engineer to be familiar with both cases in order to understand the evolution of Nevada Drainage Law and its underlying public policy considerations.

403.1 CIVIL LAW RULE

In 1885 the Nevada Supreme Court was presented with a novel question. Can an upper landowner drain artificially collected waters onto its neighbor's lower parcel? The question had never been presented before because most property owners usually complained of lack of water rather than an excess of water.

In **Boyton v. Longley**, 19 Nev. 69, 6 Pac. 437 (1885) an upper land owner used an irrigation ditch to collect water from the Truckee River and irrigate his farm. The irrigation water naturally flowed onto an adjacent parcel. The lower land owner sued to recover damages for his land and crops allegedly caused by the waste water.

The upper landowner made several arguments as follows: irrigation was necessary to cultivate his land, the lower land owned a servitude to the upper parcel to receive water which naturally flowed on to it; he had been irrigating his land for five years, and therefore had obtained a prescriptive easement across the lower piece of land. The lower land owner argued there was not a natural right to discharge water from artificial sources.

In ruling in favor of the lower land owner, the Nevada Supreme Court noted as follows:

"...As to the flow of water caused by the fall of rain, the melting of snow, or natural drainage of the ground, the prevailing doctrine is that when two tracts of land are adjacent and one is lower than the other, the owner of the upper tract has an easement in the lower land to the extent of the water naturally flowing from the upper land to and upon the lower tract, and that damage that may be occasioned to the lower land thereby is damnum absque injuria (injury without damage). Water seeks its level and naturally flows from a higher to a lower plain; hence the lower surface, or inferior surface, or superior heritage, is this: that it must receive the water that naturally falls on and flows from the level. The proprietors of the lower land cannot complain of this - this expression of the law - only applies to waters which flow naturally from springs, from storms of rain or snow, or the natural moisture of land. Wherever courts have had occasion to discuss this question they have generally declared that the servitude of the lower land cannot be augmented, or made more burdensome by the acts of industry or man." 19 Nev. at 69, 72-73.

The court observed that in order to cultivate their respective lands, both parties had to obtain irrigation water by bringing it from points remote and distant from their lands. Without the "reasonable use" of the water, the lands were comparatively worthless.

The Nevada Supreme Court held that the upper land owner, while having the unqualified right to make reasonable use of the water for irrigation, must use, manage, and control the water as to not injure an adjacent parcel. Central to the court's holding is the concept that a land owner should not be permitted to make its land more valuable by an act which renders the land of a lower landowner less valuable. This policy consideration would later be utilized by the Nevada Supreme Court almost 95 years later when the reasonable use rule was adopted.

Thus, until the reasonable use rule was adopted in 1980, Nevada Drainage Law consisted of a property law analysis of natural easements for upper parcels to drain water over lower parcels.

403.2 REASONABLE USE RULE

Approximately 95 years passed in Nevada before the Nevada Supreme Court was presented with the opportunity to change drainage law in Nevada. The court adopted the reasonable use rule in 1980 when presented with a modern factual situation which opened the door for Nevada to join the majority of jurisdictions in the western states by adopting the reasonable use rule. The case in which the reasonable use rule was adopted was controversial not only when it was decided, but remains somewhat controversial for all of the questions it does not answer.

The Nevada Supreme Court changed Nevada drainage law in **County of Clark v. Powers**, 96 Nev. 497, 611 P.2d 1072 (1980). Land owners had filed an action against the County and various developers because their activities allegedly had altered the drainage of surface waters in their area. The plaintiffs settled with the individual developers prior to trial, and proceeded to trial against the County and the County Flood Control District under theories of inverse condemnation, nuisance, and trespass. The trial court adopted the reasonable use rule and entered an award for the plaintiffs.

The Nevada Supreme Court found that during the 1950's and early 1960's, the plaintiffs had acquired their parcels and developed them for residential use. Prior to major development in the area, the land immediately west of the two plaintiffs' parcels was sufficiently porous to absorb and dissipate most rain waters. Heavy rains, however, would collect in the low surrounding areas and would follow the natural terrain entering the plaintiffs' properties at the approximate border between the two properties. These waters would flow, if at all, at a slow velocity and would be naturally dissipated and absorbed. Flooding was rare. The "ephemeral stream" on the plaintiffs' property paralleled a wash which ran to the south of the plaintiffs' parcel.

The Court found that starting in 1967 the development of the lands west of the plaintiffs' parcel resulted in the alteration, diversion, channeling and acceleration of rain, nuisance, and flood waters on to respondents' properties. The court found the County had actively participated in the development of these lands, both by its own planning, design, engineering, and construction activities and by its adoption of the similar activities of various private developers as part of the County's Master Plan for the drainage and flood control of the area.

The facts as determined at trial established various roads and intersections had been elevated, waters were collected and diverted from a grocery store site, and channeled to a drainage pipe maintained by the County. Similarly, the streets, curbs, and gutters were specifically designed to divert and channel waters onto the plaintiffs' parcels which normally would have drained to the wash. The court held that the cumulative effect of the development activities was to increase and accelerate the flow of waters through the ephemeral stream between the plaintiffs' parcels, to divert waters normally draining into

the wash onto the plaintiffs' properties, and to alter and divert the natural course of the ephemeral stream. The property was subjected to temporary but frequent and inevitable flooding.

The County argued that the civil law rule should be maintained. The Nevada Supreme Court felt that the question of which law to apply to surface water drainage entailed a judgment concerning the proper allocation of costs incident in the transformation of rural or semi-rural areas into urban and suburban communities. In making its judgment the court identified three central principles from prior decisions: one, the law of water rights must be flexible, taking notice of the varying needs of various localities; two, a landowner may make reasonable use of its land as long as he does not injure his neighbor; and three, a land owner should not be permitted to make its land more valuable at the expense of the estate of a lower landowner.

The court found that the civil law rule was ill-suited to the complexities of urban growth and expansion and that the reasonable use rule was more predictable and suited to modern development. The court held that in effecting a reasonable use of land for legitimate purpose, a landowner or user, acting in good faith, may drain surface waters and cast them on a neighbor's land if:

- 1) The injurious flow of water is reasonably necessary for drainage;
- 2) Reasonable care is taken to avoid unnecessary injury;
- 3) The benefit to the drained land outweighs the gravity of harm inflicted upon the flooded land;
- 4) The drainage is accompanied, where practicable, by the reasonable improvement and aiding of normal and natural systems of drainage in accordance with their reasonable carrying capacity; and
- 5) Where no natural systems of drainage are available, the drainage is accomplished by the use of a reasonable, artificial system of drainage.

The reasonable use rule was adopted by the court because it felt that the economic costs incident to the expulsion of surface waters in the transformation of rural and semi-rural areas into urban and suburban communities should not be borne solely by adjoining landowners. Rather, landowners, developers, and local officials, should take into account the costs of development of the community prior to the implementation of their plans. The court found that absent such prior planning, the reasonable use rule allows for a more equitable allocation of the incidental economic costs than did the civil law rule.

The County also argued it had statutory immunity for damages which were caused by "urbanization". The Nevada Supreme Court rejected the concept of limited sovereign immunity, and held as follows:

"we...chose to follow the view, adopted in a majority of jurisdictions, that a governmental entity's substantial involvement in the development of private lands which unreasonably injures the property of others is actionable". 96 Nev. a 505.

The Nevada Revised Statutes, which confer immunity from suit for discretionary acts of County employees, were not argued at the trial court level and therefore were specifically not considered on appeal. It remains an open question regarding the effect discretionary immunity might have played in this case. Similarly, the factual situation included both the acts of private developers and the county. It is therefore impossible to determine whether the court focused its decision regarding County liability on the fact that a County-constructed and maintained drainage pipe was related to plaintiffs flood problems.

Although the **Powers** case changed Nevada law, it leaves many questions unanswered such as: (1) Is the governmental entity liable for mere approval of a private development? (2) What constitutes "substantial involvement" in the development of private land? (3) Is a governmental entity liable if it

fails to detect design or construction deficiencies in a private drainage control design? (4) Is a governmental entity liable for privately designed flood control improvements which are later dedicated to the entity?

The **Powers** case is the controlling legal precedent in this state. Engineers should be aware of the balancing test set forth in the decision, as well as the underlying factual situation. The balancing test should be considered when an engineer is designing or approving alternate methods of handling water drainage. As previously mentioned, one engineer's "reasonable" drainage approach could be a juror's "unreasonable" diversion.

403.3 SURFACE WATERS - PRIVATE DEVELOPMENT

Engineers and developers working in the private sector are presented with similar liability exposure as governmental entities, but do not enjoy the same statutory protections. A brief discussion of each liability theory is important for the engineer to have a sense of the potential exposure he or she faces when proceeding with a design project.

403.3.1 NEGLIGENCE

Negligence has been defined by Black's Law Dictionary as "the omission to do something which a reasonable man, guided by those ordinary considerations which ordinarily regulate human affairs, would do, or the doing of something which a reasonable and prudent man would not do".

Placing the negligence definition into an engineering context, the reasonable and prudent man standard becomes a reasonable professional and prudent professional standard. Thus, a professional engineer who fails to act within the standard of care of his engineering profession may be held liable for negligence. The applicable standard of care is established in court by expert testimony.

The concept of negligence is composed of the traditional elements of duty, breach of the duty, the breach resulting in the proximate cause of damage, or injury. **Prosser**, Torts 143 (4th Ed. 1971). Nevada courts and courts across the nation have broadly interpreted the duty element as a duty being owed to all persons who may foreseeably be affected by the work being performed.

In order for the engineer to determine if he faces potential negligence exposure, it is helpful to analyze the project and its relation to the engineering activities which are being performed. The engineer should attempt to determine what the standard of care in his profession is in relationship to the particular engineering task being performed and then make a realistic evaluation as to whether or not the services rendered would meet that standard. For example, using the Rational Method for a watershed which exceeds the size set forth in the manual, rather than the HEC-1 computer model required by this manual, may fall below the standard of care and could result in potential liability. The engineer should always strive to use the best information available and also strive to use methods which are state of the art and widely accepted by the engineering profession.

Complying with legally required procedures (i.e. contained in this manual) has been held by the courts to be a **minimum** standard of care.

Unfortunately, an engineer cannot always be guaranteed that by merely following the computer models and design procedures contained in this manual he will be insulated from negligence liability. It is possible that in a particular area of design the engineer's standard of care could require a higher standard of engineering practice. However, following the requirements of this manual will help to substantially establish that an engineer has met the accepted standard of care.

403.3.2 BREACH OF EXPRESS/IMPLIED WARRANTY

This liability theory can be based on either an implied warranty or an express warranty. Under this particular theory of liability an engineer does not face the same exposure as a developer who actually sells a finished product.

The courts have generally held that an implied warranty normally requires privity of contract between the person bringing the action and the party who allegedly breached the implied warranty. An implied warranty only relates to the product and may not be imputed to one who has provided services as opposed to the product. Thus, a private engineer who has designed plans does not face the same liability exposure as a developer who has sold a completed product.

403.3.3 FRAUD/MISREPRESENTATION

Fraud is a much less commonly-pled liability theory because it is much harder to prove. The court requires "clear and convincing" evidence that fraudulent conduct has occurred.

Fraud in the general sense is deemed to be any conduct which is calculated to deceive another person or entity and results in damage.

The essential elements required to sustain a fraud action are the representations made as a statement of fact (non genuine) which was untrue and known to be untrue by the party making it, or recklessly made; that the statement was made with intent to deceive and for the purpose of inducing the other party to act upon it, and the person did in fact rely on it and was induced to act to his detriment. Am.Jur. 2d, Fraud & Deceit, Sections 2, 12.

An example of fraudulent conduct would be an engineer or developer telling a potential home purchaser that the home was not located in a flood plain when the engineer/developer knew for a fact that the statement was false. If the purchaser relies on that representation and purchases a home in the subdivision, then a potential case of fraud exists.

403.3.4 TRESPASS

Trespass is an injury to possession. It is an intrusion which invades a person's protected interest in exclusive possession. A trespass action requires active conduct on the part of the wrongdoer. Liability can be imposed for intentional, negligent or ultrahazardous activity. The only "intent" required is that the act constituting the trespass is voluntarily done. An act may constitute a trespass despite the fact that its consequences were unintended. 75 Am.Jur.2d, Trespass, Section 8.

In general, one is subject to liability for trespass to real property if one intentionally enters land in the possession of another or causes a thing or force to do so. A landowner who sets in motion a force which, in the usual course of events, will damage the property of another is guilty of trespass on such property. **Burt v. Beautiful Savior Lutheran Church**, 809 P.2d 1064 (Colo.Ap. 1990).

Nevada has defined trespass as an injury to an estate, or use thereof, by one who is a stranger to the title of the injured property. **Price v. Ward**, 25 Nev. 203, 58 Pac. 849 (1899).

An example of this liability theory would be damage to real property caused by waters escaping from a drainage channel or damaging a subdivision as a result of an improperly designed drainage system. The damage occurs when the water flows on the person's property and in turn damages the real property, personal property, and possessory interest of the landowner. Such damage easily occurs once water begins to flow onto a property and into the front door of someone's home. The landowner need not prove that the engineer or developer intentionally flooded the property, but merely that the

act of designing and constructing the flood control improvement were done voluntarily. As previously noted, the liability for trespass can be based on negligent conduct.

Flooding of a person's property because of improper construction of highway embankments constitutes trespass. **Viestenz v. Arthur TP**, 54 N.W. 2d. 572 (ND 1952). Where the defendant's affirmative act results in the flooding of the plaintiff's land and the destruction of crops, the defendant has constituted trespass. **Western Union Tel. Co. v. Bush**, 89 S.W.2d 723 (Ark. 1935). However, floods resulting solely from a severe storm do not constitute trespass. **Hughes v. King's County**, 714 P.2d 316, (Wash.Ap. 1986).

Pursuant to the trespass liability theory, damages generally constitute the difference in value of the land both before and after the act. Damages can also include the loss of use of the land, discomfort and annoyance to the property owner, cost of repair, and lost crops.

403.3.5 NUISANCE

The "nuisance" liability theory applies to that class of wrongs that is covered by the unreasonable, unwarrantable, or unlawful use by a person of his property, or from his improper, indecent or unlawful conduct, which operates as an obstruction or injury to the right of another or to the public, and producing such material annoyance, inconvenience, discomfort or hurt that the law will presume consequential damage. **Bliss v. Grayson**, 24 Nev.422, 56 Pac. 231 (1899).

The term "nuisance" is incapable of an exact and exhaustive definition which will fit all cases because the factual situations are seldom alike. Nevertheless, "nuisance" has been defined as a distinct civil wrong, and is used to describe the wrongful invasion of a legal right or interest. "Nuisance" includes everything that endangers life, health, or obstructs the reasonable and comfortable use of property. 58 Am.Jur. 2d, Nuisance, Section 1.

Nuisance and trespass are analogous in some respects. However, there is a distinction between them, the difference being that a trespass is an invasion of the person's interest in the exclusive possession of his land (as by entry on it) while a nuisance is an interference with the use and enjoyment of the land, and does not require interference with the possession. The requisites that an interference be substantial and unreasonable, in order to constitute a nuisance, have been said to distinguish an action for nuisance from that of trespass. In this regard, an action for trespass can be maintained without a showing of damage because it is the unauthorized entry upon the land that creates the trespass and the presumed damage.

A claim of nuisance is more than a claim of negligence. Negligent acts do not in themselves constitute a nuisance; rather, negligence is merely one type of conduct upon which liability for nuisance may be based.

This liability theory primarily involves the annoyance and inconvenience which people experience once their property has been flooded. The flood clean-up process and associated odors, filth, and insect infestation would fall within this theory. In many ways, this theory closely tracks claims for emotional distress and can provide dramatic testimony for a jury. Even something as minor as increased flow in an irrigation ditch has been deemed a nuisance in Nevada. **Thomas v. Blaisdell**, 25 Nev. 223, 58 Pac. 903 (1899).

403.3.6 STRICT LIABILITY

Nevada has recognized that an end user of a "product" has established a cause of action in strict liability against a manufacturer or distributor when "his injury is caused by a defect in the product, and

[the user proves] that such defect existed when the product left the hands of the defendant". **Shoshone Coca-Cola Bottling v. Dolinski**, 82 Nev. 439, 443, 420 P.2d 855, 858 (1966).

California has applied the strict liability theory to the sale of homes and defective lots. The Nevada Supreme Court noted in **Elley v. Steven**, 104 Nev.Adv.Op. 62, N.2 (1988) that courts are divided about whether a home is a product under strict liability theory. In that case the Nevada Supreme Court was presented with this issue but was able to decide the case without ruling on the applicability of the strict liability theory. As the law currently stands in Nevada, the strict liability theory does not apply to homes. However, this theory could be extended to a situation where a "product" is sold by someone in the regular course of its business.

403.3.7 PUNITIVE DAMAGES

The above liability theories can support both an award of compensatory damages and punitive damages. Compensatory damages are to compensate a person for specific damages such as property repair or replacement costs. However, the private developer faces a possible award of punitive damages which can be unrelated to the actual damages suffered by the landowner.

NRS 42.010 provides as follows:

"In an action for the breach of an obligation not arising from contact, where the defendant: (1) has been guilty of oppression, fraud or malice, expressly implied; or (2) caused an injury by the operation of a motor vehicle in violation of NRS 484.379 or 484.3795 after willfully consuming or using alcohol or another substance, knowing that he would thereafter operate the motor vehicle.

The plaintiff in addition to actual damages, may recover damages for the sake of example and by way of punishing the defendant."

The concept of punitive damages rests upon a presumed public policy to punish a wrongdoer for his act and to deter others from acting in similar fashion. The punitive damage allowance should be in an amount that will promote the public interest without financially annihilating the defendant. **Nevada Cement Company v. Lemier**, 89 Nev. 447, 514 P.2d 1180 (1973).

Since the purpose of punitive damages is to punish and deter culpable conduct, the award lies in the discretion of the court or jury and need not bear a fixed relationship to the compensatory damages awarded. **Randano v. Turk**, 86 Nev. 123, 466 P.2d 218 (1970).

The "malice" contemplated in NRS 42.010 is malice in fact and which the malice is established. Malice in fact sufficient to support an award of damages may be established by a showing that the wrongful conduct was willful, intentional and done in reckless disregard of its possible results. **Nevada Credit Rating Bureau, Inc. v. Williams**, 88 Nev. 601, 503 P.2d 9 (1972).

In **Village Development Company v. Filice**, 90 Nev. 305 P.2d 83 (1974), the Nevada Supreme Court was presented with a case involving a claim for damages arising from the destruction of a home constructed in an undisclosed flood plain and the subsequent claim for punitive damages. The lot purchaser brought an action to recover damages from the developer of a lot which was situated in an undisclosed flood plain of a mountain stream. The District Court awarded compensatory and punitive damages and the developer appealed. The Nevada Supreme Court found the developer was aware that a stream which crossed the plaintiff's lot usually was quite narrow but varied radically under various storm conditions of given return frequencies. Despite knowledge of the developer's officers regarding the extent of the flood plain, the developer did not impose any building restriction other than requiring

that building plans be submitted to an architectural control committee. Knowing of the flood hazard, the developer assumed the plaintiff would build on the highest possible site on the lot, but never advised the lot purchasers of its thoughts regarding a property building site. In short, the court found that the corporation's highest management personnel failed to warn of the danger although they well knew the plaintiffs were planning to build in the flood plain. Plans were submitted to the architectural control committee and approved without warning.

The court held that there was ample evidence to support a jury instruction regarding negligence and that the resulting award under that theory was proper. After carefully reviewing the record, the court found that although there was ample evidence of negligence and unconscionable irresponsibility, there was insufficient evidence to support a finding of "oppression, fraud or malice express or implied". The court noted it had previously sustained punitive damage awards when the evidence showed the wrong was willful. Here, the evidence was insufficient to meet the requirement that more must be shown than malice in law, and that there should be substantial evidence of malice in fact.

The above case indicates how the private developer can face punitive damage exposure. Although in the case above the developer escaped punitive damage exposure, it could easily have faced punitive exposure if representations had been made to the purchaser such as the property was not located in the flood plain, or that flooding was not likely in that area. If an area is located in a flood plain that fact should be fully disclosed to the purchaser and proper engineering procedures consistent with the standard of care should be followed.

404 SURFACE WATERS - GOVERNMENTAL ENTITY LIABILITY

The liability of a governmental entity with respect to surface waters is treated differently in some respects than the liability of a private developer even though the same liability theories previously discussed can be asserted. The state legislature has conferred various statutory defenses, immunities and damage limitations in view of the burden regarding land development which has been placed upon the governmental entities. Governmental entity tort liability is controlled by Chapter 41 of the Nevada Revised Statutes which was adopted in 1965.

404.1 SOVEREIGN IMMUNITY

The principle of sovereign immunity can be traced back to ancient times in England when a person could not sue the King. This concept has carried through common law and has appeared in statutory provisions in most states. NRS 41.031 contains a waiver of sovereign immunity which is expressly limited by several other statutes containing specific defenses. The purpose of the limited waiver of sovereign immunity is to compensate the victims of governmental negligence in circumstances like those in which victims of private negligence would be compensated. **Harrigan v. City of Reno**, 86 Nev. 678, 475 P.2d 94 (1970).

The legislative intent in enacting NRS 41.031 was to waive the immunity of governmental units and agencies from liability for injuries caused by their negligent conduct, thus putting them on equal footing with private persons committing torts. **Jimenez v. State**, 98 Nev. 204, 644 P.2d 1023 (1982).

In close cases where the issue of whether the allegations of conduct fall within the parameters of a waiver of sovereign immunity, courts must favor a waiver of immunity; only when it is concluded that a discretionary act alone is involved, will the court find immunity. **Hagblom v. State Director of Motor Vehicles**, 93 Nev. 599, 571 P.2d 1172 (1977). NRS 41.031 initially provided for a special claims procedure when a person wanted to sue the state. However, the Nevada Supreme Court eliminated this requirement in 1973.

404.2 NRS 41.032 - DISCRETIONARY IMMUNITY

NRS 41.032 provides that no action may be brought under the limited waiver of immunity statute or against an officer or employee of the state or any of its agencies or political subdivision which is based upon the following:

- a. An act or omission of an officer or employee, exercising due care, in the execution of a statute or regulation, whether or not such statute or regulation is valid, if the statute or regulation has not been declared invalid by a court of competent jurisdiction; or
- b. Based upon the exercise of performance or the failure to exercise or perform a discretionary function or duty on the part of the state or any of its agencies or political subdivision or any officer or employee of any of these, whether or not the discretion involved is abused.

The discretionary function immunity initially was a very strong defense for governmental agencies. However, over the years various interpretations of the statute by the Nevada Supreme Court have eroded its effectiveness.

The Nevada Supreme Court has analyzed discretionary immunity in terms of the type of functions the governmental entity is performing at the time. The governmental (discretionary) function is the initial decision to act. A discretionary function can be categorized as a decision to build a freeway, flood control channel, or parking structure. Once the discretionary decision to act has been made, then the governmental entity shifts into the operational function which usually involves construction and design. The governmental entity is obligated to use due care when acting in the operational function area.

The discretionary immunity cases can generally be divided into the following areas: road/street, police protection, and miscellaneous. One case from each area will briefly be discussed to give the engineer a sense of the analysis which is engaged in by the Supreme Court.

In the case of **State v. Webster**, 88 Nev. 690, 504 P.2d 1316 (1972), horses wandered onto a frontage road and then onto a newly constructed controlled access freeway near Carson City. An accident later resulted when a car struck the horses. The plaintiffs sued the State on the theory that the state was negligent for not providing a fence to keep animals off the freeway. The Nevada Supreme Court held that the governmental (discretionary) function was the decision to build a controlled access freeway, rather than continuing an old two lane highway. Once the discretionary decision regarding construction was made, the State was obligated to use due care to make the freeway meet standards of reasonable safety. The court held the State was negligent for failing to install a cattle guard.

In **Parker v. Mineral County**, 102 Nev.Ad.Op. 131 (1986), a person cutting firewood saw another person lying on the side of a rural road who apparently needed help. After the person on the ground had refused assistance, the firewood cutter reported the incident to a Sheriff's Deputy who said they would take care of the situation. No one responded to the report and the person by the side of the road later died of exposure. The police department was sued for failure to respond to the call. The Nevada Supreme Court, in upholding a ruling in favor of Mineral County Sheriff's Department, held that personal deliberation, decision and judgment are the requirement of a discretionary act. In deciding not to respond to the call the County officials exercised their personal judgment as to how their limited resources should be utilized to best promote the public good. Such a decision could not be second guessed by the court.

In **Esmeralda County v. Grogan**, 94 Nev. 923 (1978) the Nevada Supreme Court held that the decision to grant, revoke, or withhold a liquor license is a discretionary act.

404.3 NRS 41.033 - FAILURE TO INSPECT

NRS 41.033 provides that an action may not be brought against the state under the waiver of sovereign immunity or against an officer or an employee of the state based upon the following:

- a. Failure to inspect any building, structure or vehicle, or to inspect the construction of any street, public highway or other public work to determine any hazards, deficiencies or other matters, whether or not there is a duty to inspect; and
- b. Failure to discover such hazard, deficiency or other matter, whether or not an inspection is made.

An initial reading of this statute would seem to confirm broad protection for the governmental entity. However, subsequent interpretations of this statute by the Nevada Supreme Court eroded its effectiveness.

The protection provided by this statute can only be obtained if the government entity does not have actual notice of a hazard or dangerous condition. For instance, in **Crucil v. Carson City**, 95 Nev. 583, 600 P.2d 216 (1979) it was held that where the city allegedly had knowledge of a downed stop sign in an intersection and failed to act reasonably after discovering it, that NRS 41.033 did not provide immunity against such suit.

The state's protection under NRS 41.033 can also be altered by contract. In 1975 the City of North Las Vegas was sued when a person was electrocuted while working on a billboard and touched a high voltage line. Approximately 20 years before the accident the City had signed a franchise agreement with Nevada Power in which the City agreed to inspect the power lines in return for a certain percentage of the gross revenues attributable to the citizens of North Las Vegas. The court held the agreement imposed a contractual duty to inspect the power lines which superseded any protection provided by NRS 41.033.

In **Butler v. Bogdanovich**, 101 Nev. 499 (1985) a person built a home that was inspected and approved by the County. Several years later the plaintiffs purchased the home and found approximately 25 substantial building code violations and sued the County. The Nevada Supreme Court held that if the County had knowledge of the defects, the County owed a duty to the plaintiffs to take action as a result of the discovery of the deficiencies. The court held sovereign immunity would not bar actions based upon a public entity's failure to act reasonably after learning of a hazard. This case highlights the effect of actual notice eliminating certain sovereign immunity defenses.

404.4 LIMITATION OF TORT DAMAGE AWARDS

NRS 41.035 generally provides two important limitations on the types of damage claims which can be awarded against a governmental entity.

The first limitation on damages awards limits a person's recovery in tort against a governmental entity to a maximum of \$50,000. The stated damage limitation applies to an individual for each cause of action which may be asserted against the state, regardless of how many actions he or she may have, even if more than one action arose from a single event. **State v. Webster** 88 Nev. 690, 504 P.2d 1316 (1972).

The second important damage limitation prevents an award of punitive damages against the state. This is a very important distinction between governmental and private liability. A private developer may be held liable in punitive damages which can range far in excess of any compensatory damages which are awarded to a plaintiff, while a governmental entity is protected from such damages.

However, governmental entities can be sued in inverse condemnation while a private developer is protected from such an action.

404.5 INVERSE CONDEMNATION -EMINENT DOMAIN

The subject of eminent domain is extremely complex. However, a brief overview of this area is necessary for the engineer.

Article 1, Section 8 of the Nevada State Constitution provides in pertinent part that private property shall not be taken for public use without just compensation having been first made or secured, except in cases of war, riot, fire, or great public peril, in which case compensation will be made later. Private property cannot be taken for a private use and can only be taken for a public use by a specific act of the governmental entity.

Eminent domain and inverse condemnation are basically the same concept but from a different perspective. If a governmental entity needs to obtain land for the construction of a flood control project, then the land is obtained by filing an eminent domain proceeding in which the land is condemned and the landowner is paid "just compensation" for the land. If a landowner claims that his property has been taken for public use without just compensation being first made, then an inverse condemnation action is filed by the landowner seeking compensation from the governmental entity for the land.

Chapter 37 of the Nevada Revised Statutes governs eminent domain actions. Specifically, NRS 37.010(3) and (5) provide that the right of eminent domain may be exercised for the public purpose of "draining any county" or "for draining and reclaiming lands". Thus, obtaining property for flood control purposes has been specifically recognized by state statutes. Chapter 37 contains the statutes governing the acquisition and valuation process.

Chapters 340 and 342 of the Nevada Revised Statutes contain additional information regarding eminent domain procedures and acquisition of real property. Of particular interest is NRS 342.280 which provides that no public body shall intentionally make it necessary for an owner to institute legal proceedings to prove the fact of the taking of his real property.

The Courts have generally upheld the concept that drainage improvements are public purposes. A public drainage ditch has been held to be for a public purpose under eminent domain, and therefore required compensation for private property taken or damaged in the construction thereof. **Eminent Domain**, 26 Am.Jur.2d Section 44. The courts quite generally have come to consider drainage district acts with favor as being for public purpose, whether exercised for the benefit of public health or for the reclamation or utilization of lands for agricultural purposes.

The Nevada Supreme Court specifically recognized the inverse condemnation theory in **County of Clark v. Powers**, supra. In that case the plaintiffs' properties were repeatedly flooded as a result of development activities of upstream developers. The court found the property no longer had a practical use other than as a flood control channel. The court noted in a footnote on page 501 of the decision as follows:

"It has long been established that a taking occurs where real estate is actively invaded by superinduced additions of water...so as to effectively destroy or impair its usefulness", **Pumpelly v. Green Bay Company**, 80 U.S. (13 Wall.) 166, 181, (1871), and the result is no different when property is subjected to intermittent, but inevitable flooding which causes substantial injury. **United States v. Cress**, 243 U.S. 316, 328 (1917).

Thus, private property which is subject to intermittent but inevitable flooding can be "taken" as a result of governmental flood control projects. However, each of the cases is highly dependent upon its factual situation. Inverse condemnation liability extends to "just compensation" for the highest and best use of the property. The previously mentioned \$50,000 damage limitation applies only to tort actions and does not apply to inverse condemnation actions. Additionally, the sovereign immunity defenses such as discretionary immunity, and failure to inspect immunity, are not available to the governmental entity because the right to just compensation for private property taken for a public use cannot be abridged or impaired by statute. Alper v. Clark County, 93 Nev. 569, 571 P.2d 810 (1977) cert. denied, 436 U.S. 905, 98 S.Ct. 2235, 56 L.Ed. 2d 402 (1978).

SECTION 500 - DRAINAGE PLANNING AND SUBMITTAL

TABLE OF CONTENTS

	<u>Page</u>
501 PURPOSE.....	501
502 REQUIRED DRAINAGE REPORT SUBMITTALS	501
502.1 GENERAL.....	501
502.2 SUBMITTALS.....	502
502.3 EXEMPTIONS	502
502.4 DRAINAGE MASTER PLANS	503
503 CONCEPTUAL DRAINAGE REPORT.....	503
503.1 REPORT CONTENTS.....	503
503.2 DRAINAGE PLAN	504
504 TECHNICAL DRAINAGE REPORT.....	505
504.1 REPORT CONTENTS.....	505
504.2 DRAINAGE PLAN	509
504.3 CALCULATIONS EXEMPTION	510
504.4 IMPROVEMENT PLANS.....	510
505 TECHNICAL DRAINAGE REPORT ADDENDUM	510
506 IMPROVEMENT PLANS	511
507 REQUIREMENTS FOR A FLOOD PLAIN STUDY.....	511
507.1 OUTLINE FOR A FLOOD PLAIN STUDY	512
507.2 FEMA DESIGNATED FLOOD PLAINS	512

SECTION 500

DRAINAGE PLANNING AND SUBMITTAL

501 PURPOSE

The purpose of a Drainage Report is to present conceptual or technical information to demonstrate that proposed drainage designs will adequately detain and convey design-storm runoff in accordance with the policies and standards set forth in this Manual. The goal of Drainage Report Submittal Standards is to obtain consistency in information, analysis content, and presentation to minimize time and effort needed to prepare and review the proposed drainage design.

Drainage Reports will be reviewed for compliance and consistency with the drainage policies and design standards established in this Manual. These policies and standards establish the minimum requirements for drainage analysis and design. The design engineer is ultimately responsible for the drainage facilities design and determining if drainage facilities which exceed the standards established herein are necessary to fully protect the proposed project and citizens from drainage and flood hazards.

By reviewing and accepting drainage designs for given developments, the Jurisdictional Entities will not assume liability for improper drainage design nor guarantee that drainage design reviews will absolve the developer or designer of future liability for improper design.

502 REQUIRED DRAINAGE REPORT SUBMITTALS

502.1 GENERAL

The Jurisdictional Entities utilize two types of Drainage Reports for the drainage submittal and review process: the Conceptual Drainage Report and the Technical Drainage Report.

The Conceptual Drainage Report is a condensed report which conceptually addresses drainage problems and proposed solutions. This conceptual report provides the Jurisdictional Entities information needed to enable a general review of drainage conditions at a site, and an evaluation of the feasibility and adequacy of the storm drainage systems proposed in concept. The Conceptual Drainage Report is also used to identify drainage easements and, at a conceptual level, evaluate their adequacy for proposed uses. For large projects that will be constructed in phases, the Conceptual Drainage Report can act as a local master plan and provide a basis for the design of future phased development. With respect to larger projects for which final designs will be immediately pursued, the Conceptual Drainage Report can provide a means for the submittal of conceptual designs for approval prior to the development of the more detailed Technical Drainage Report typically required for such projects. In certain cases, the Conceptual Drainage Report may be used to demonstrate that a proposed project will have little or no impact on downstream properties and drainage structures, and that further drainage analysis is not warranted.

The Technical Drainage Report provides detailed hydrologic and hydraulic analyses used for the design of proposed drainage facilities per the guidelines and standards set forth in this Manual. This report also presents drawings depicting drainage easement boundaries, layout of drainage facilities, grading plans and special details required for proposed drainage structures. The information presented in the Technical Drainage Report should be of sufficient detail and comprehensiveness to enable the reviewing agencies to determine that all storm drainage designs proposed in the report will perform the intended purposes adequately and in conformance with the applicable design criteria.

In addition to the Technical Drainage Report, an Addendum to the report will be required if, during final design or development of the construction drawings, design changes require modification of the hydrologic or hydraulic analyses presented in the Technical Drainage Report. The Addendum should present a discussion of the cause for changes, a description of the changes, and complete computations and other backup data used for developing the design modifications. Revised designs at a level of detail compatible with the Technical Drainage Report previously submitted and approved should also be included in the Addendum.

502.2 SUBMITTALS

In order to standardize the drainage submittal and review process, the Drainage Report submittal requirements for all land development processes, land disturbance projects and improvement projects are presented in Table 501.

The submittal requirements are tailored to provide the minimum amount of information necessary for each development process and size of development, or type and size of land disturbance or improvement project. The approval of a drainage report and accompanying proposed designs does not, however, relieve the design engineer of the responsibility to provide a correct and safe drainage design nor the developer to properly construct the designed drainage facilities.

All submitted reports should be clearly and cleanly reproduced. Photostatic copies of charts, tables, nomographs, calculations, or any other referenced material should be legible. Washed out, blurred, or unreadable portions of the report are unacceptable and will warrant resubmittal of the report. Drainage Plans submitted with reports should be clearly legible with appropriate symbols used to identify all relevant drainage structures. Where spreadsheets are used, formulas shall be provided.

A checklist of required items for each drainage report type is presented on the "Drainage Submittal Checklist" (Standard Form 1/Section 1500). This checklist will be used by the Jurisdictional Entities to initially determine if the minimum submittal requirements have been met. If the submittal does not meet the minimum requirements, the submittal will be returned to the submitting party with the deficiencies noted. These deficiencies must be corrected and resubmitted before the submittal will be accepted for review.

502.3 EXEMPTIONS

Exemptions to the Drainage Report Submittal Requirements may be granted by the Jurisdictional Entities for just cause. Those processes/projects which can clearly demonstrate, without detailed analysis, that no adverse impacts will result to the on-site and downstream drainage systems may be exempted from submitting a Conceptual or Technical Drainage Report. Certain items of the submittal requirements may be waived if it is clearly demonstrated to and agreed by the Jurisdictional Entity, prior to submittal of the report for review, that the subject information is not needed to fulfill the intent of the report. Requests to the Jurisdictional Entities for such exemption or waiver shall be made in writing. For approved requests, the Jurisdictional Entities shall provide to the requesting party a written confirmation of the exemption or waiver granted. If such exemption or waiver is so granted, the project developer will be required to submit a statement by a Nevada Registered Civil Engineer stating that the proposed project fully meets the policy, analysis and design requirements of this Manual.

502.4 DRAINAGE MASTER PLANS

Submittal requirements for drainage master plans may require Conceptual Drainage Reports, Technical Drainage Reports, or both. It is recommended that, during the conceptual development of a drainage master plan, a meeting should be held between the developer, the Jurisdictional Entity, and, if applicable, any regional agencies to identify major issues that may affect proposed master-planned drainage facilities.

Discussion with the Jurisdictional Entity should be held to determine what level of analysis will be appropriate for the proposed drainage master plan. Particular attention will need to be given to project phasing, compatibility with adjacent existing or proposed local and regional drainage systems, and compatibility with existing master plan analyses. The master plan drainage report submittal should provide a comprehensive discussion of all relevant issues that affect the design and implementation of the subject local and regional drainage facilities.

503 CONCEPTUAL DRAINAGE REPORT

A Conceptual Drainage Report is a condensed report which conceptually describes existing and proposed drainage conditions and facilities. The purpose of the Conceptual Drainage Report is described above in Section 502. The Conceptual Drainage Report shall contain a brief narrative letter, a calculation appendix (if applicable), and a drainage plan in accordance with the following outline. The report should include the information described in the outline as appropriate.

503.1 REPORT CONTENTS

- I. Title Page
 - A. Project Name and Type of Study
 - B. Preparer's Name, Firm, and Date
 - C. Professional Engineer's Seal and Signature

- II. Introduction
 - A. Location of project by street location, assessor's parcel number(s), and ¼ Section, Section, Township and Range
 - B. Description of Project
 - C. Existing Site Conditions
 - D. Description of readily available previous studies and relevant Master Plans including full references (if applicable)

- III. Existing and Proposed Hydrology
 - A. Discuss existing and proposed drainage basin boundaries
 - B. Present existing and proposed minor and major storm flow calculations
 - C. Discuss existing drainage problems (if applicable)

- IV. Proposed Drainage Facilities
 - A. Discuss routing of flow in and/or around site and location of drainage facilities
 - B. Discuss need for detention and requirements per Section 303.7 of this Manual
 - C. Discuss proposed flood plain modifications (if applicable) and need for FEMA approval

- D. Discuss outfall system and anticipated phasing for relevant future facilities proposed by others (if applicable)
- V. Conclusions
 - A. Compliance with all Manual policies and requirements
 - B. Requested Manual exemptions
 - C. Ability to provide emergency all weather access
 - D. Compliance with flood plain/flood hazard regulations
 - E. Discuss effect of development on off-site flow rates, volumes, patterns and impact to all adjacent and downstream properties and drainageways
- VI. Exhibits and Figures
 - A. General Location Map (8½" x 11" is suggested)
 - B. Off-site Basin Map (with topographic information at suitable scale)
 - C. Drainage Plan (see Section 503.2)
- VII. Calculations Appendix
 - A. Runoff calculations
 - B. Street and drainage facility capacity calculations
 - C. Detention calculations (if applicable)
 - D. Copies of all tables, charts, etc. used for calculations with source noted

503.2 DRAINAGE PLAN

An 8 ½" x 11" or larger legible drainage plan which covers the development area addressing existing and proposed conditions shall be submitted and bound with the Conceptual Drainage Report. As a minimum, the plan shall:

1. Locate and label development boundary
2. Locate and label adjacent streets
3. Locate and label known 100-year flood plains
4. Locate and label existing and planned regional and local off-site drainage facilities
5. Locate and label proposed on-site drainage facilities including the necessary detention area
6. Show flow paths
7. Identify design inflow points and design outflow points and corresponding minor and major storm flow rates
8. Show drainage basin boundaries and basin labels
9. Provide adequate information to identify proposed land cover types within project area
10. Identify drainage basin areas, runoff coefficients (existing and proposed) and curve numbers as applicable
11. Identify all drainage easements

12. Show existing and proposed grading topographic contours 100 feet past the property line. (Spot elevations in lieu of topography past the property line may be used only upon prior approval of the Jurisdictional Entity.)

Note: The Drainage Plan stated above is preferred; however, multiple exhibits containing the same information may be submitted.

504 TECHNICAL DRAINAGE REPORT

The Technical Drainage Report discusses at a detailed level the existing site hydrologic conditions and the proposed drainage design to accommodate or modify these site drainage conditions in the final development plan for the site. The Technical Drainage Report addresses both on-site and off-site drainage analyses and improvements required for compliance with the policies and criteria set forth in this Manual.

The Technical Drainage Report shall be in accordance with the following outline and contain the applicable information listed.

504.1 REPORT CONTENTS

- I. Title Page. The title page of the Drainage Report shall contain the following:
 - A. Project Name
 - B. Preparer's Name, Firm and Date
 - C. Professional Engineer's Seal and Signature
- II. Introduction. The introduction of the Drainage Report shall include, at a minimum, the following:
 - A. Identification of street location, Assessor's parcel number(s), section reference, and adjacent developments
 - B. General description of existing site conditions
 1. Topography, ground cover, soils, etc.
 2. Existing drainage and irrigation facilities
 3. Existing flood hazards (Flood plains, alluvial fans, etc.)
 - C. General description of proposed project
- III. Previous Studies

This section should provide a description of all previous studies readily available and relevant to the proposed project. Include all drainage reports, master plans and flood hazard studies, and discuss their relevance to the project. Provide full reference for all information sources.
- IV. Hydrologic and Hydraulic Analysis
 - A. Describe method used for runoff computations
 - B. Discuss design storm intensities or depths for 5- and 100-year storms
 - C. Describe method used to determine hydrologic parameters, and include reference to the appendix containing hydrologic computations. Include appropriate geotechnical information if used to support the hydraulic design (i.e. natural channels).

- D. Describe methods used for hydraulic computations. Discuss typical parameters used, and include reference to the appendix containing hydraulic computations. Include appropriate geotechnical information if used to support the hydraulic design (i.e. natural channels).
- E. All computer programs used for modeling shall be identified including version and release number. Include input and output file printouts in the appendix.
- V. Historic Drainage System. The Drainage Report shall provide sufficient information, including text and maps where possible, to describe the historic drainage system. This information shall include:
 - A. Major basins (100 acres or more), including relationship to major drainage facilities, and major basin drainage characteristics (topography, runoff, cover, use, erosion).
 - B. Sub-basin and site drainage, including 5-year and 100-year storm flows for each sub-basin affecting the site, existing drainage patterns, channeled or overland flow, points of entrance and discharge, flood hazard areas, and other drainage related features. A map showing off-site basins shall also be included. All items listed in Subsections A and B may be presented on a map or drawing.
 - C. Discussion of hydrologic and hydraulic analysis results for existing drainage conditions and facilities, including those items on drawings and maps not discussed elsewhere. Discussion shall include flow rates and paths, drainage facilities, irrigation ditches, impact of site runoff on adjacent properties, and any other relevant information.
- VI. Proposed Drainage System. As a minimum, the following information regarding the proposed drainage system shall be provided in the Drainage Report. Maps shall be used to complement and clarify the description where appropriate.
 - A. Description of major basins and tributary sub-basins. Refer reader to appropriate figures or drawings.
 - B. Results of hydrologic and hydraulic analyses. Include summary tables if needed to facilitate discussion of results. Refer reader to the appropriate appendix, if applicable.
 - C. Description of the proposed storm drainage system to manage design storm runoff. Discussion should include management of off-site runoff tributary to the project site, on-site flows, and anticipated phasing of future downstream facilities that comprise the off-site drainage system for the proposed project. Identify any interim facilities that need to be constructed, and the authority under which such facilities will be constructed, until permanent off-site drainage facilities are in place. The intent of the off-site facilities information is to permit the reviewing agencies to determine the impacts of proposed development on off-site facilities and property prior to the construction of permanent off-site local or regional drainage systems. Discuss capacity of system to pass both the minor and major storm design flows within and through the development.
 - D. Discussion of potential for and risk of sediment inflow and debris flow into the proposed drainage facilities.
 - E. Discussion of Water Quality Structural Controls. This discussion shall include:
 - 1. Site design planning efforts for water quality enhancement
 - 2. Design and sizing calculations for flow-based storm water treatment facilities

3. Design and sizing calculations for volume-based storm water treatment facilities
 4. Design and sizing calculations for water quality diversion and release structures
 5. Water quality volumes required and provided
 - F. Discussion of detention requirements for the 5- and 100-year storms per Section 303.7 of this Manual. For proposed detention facilities the following information shall be provided:
 1. Volume required and provided for zero increase in peak flows
 2. Release rates and methods
 3. Passage of runoff from storms exceeding the 5-year up to the 100-year storm
 4. Emergency overflow provisions which will not cause a direct impact to neighboring sites
 5. A detailed description of downstream constraints and mitigation recommendations
 6. Description of detention areas and proposed multiple uses, as applicable. Identify maximum ponding depths for design storms. Refer reader to appropriate calculations appendix.
 - G. Discussion of compatibility of proposed design with previous studies. Provide justification of deviation from any design constraints recommended or imposed by previous studies or master plans.
 - H. Discussion of any drainage easements or rights-of-way relevant to the project. For drainage easements dedicated as part of the project, the report should identify the parties subject to the agreements and the form of conveyance of said easements (i.e., final plat, separate deed, etc.).
 - I. Identification of parties and/or entities responsible for maintenance of the private and/or public drainage systems constructed as part of the proposed project. Provide an operations and maintenance manual for all private drainage systems to be recorded as a CCR attachment. The report should identify any agreements that define such maintenance responsibilities.
- VII. Where the proposed development is located within a special flood hazard area or critical flood storage area as defined in the appropriate local code, sufficient information shall be provided for the following:
- A. Evaluation of the impacts of proposed development on the flood hazard area within the project area and with respect to adjacent properties. If specific analysis was performed for flood hazard area consideration, include description of analysis and pertinent backup data and calculations as applicable.
 - B. Identification of floodproofing or other protective measures for improvements to be constructed in the flood hazard area.
 - C. Description of impact of the flood plain on the proposed storm drainage system(s).
 - D. Discussion of compliance with FEMA requirements for Conditional Letter of Map Revision (CLOMR) / Letter of Map Revision (LOMR) submittal, if applicable. Include reference to all CLOMR/LOMR's submitted to FEMA for this project.
 - E. Discuss compliance with the appropriate local code.

- VIII. Conclusions. This section shall discuss the impacts of the proposed drainage system improvements, including:
- A. Compliance with all Manual policies and requirements
 - B. Requested Manual exemptions
 - C. Compliance with State and Federal Regulations
 - D. Compliance with local flood plain/flood hazard regulations
 - E. Benefits provided by the proposed facilities to off-site systems
 - F. Adverse effects to off-site systems and mitigation measures for these effects
 - H. Ability to provide emergency all weather access
- IX. References. Include references for all sources of information used in report.
- X. Drainage Report Appendices. The Drainage Report shall include the following information in the Appendices.
- A. Site Location Map. Site location may be on a USGS map, at a scale appropriate to show relation of site to major drainage basins and sub-basins; flood hazard areas and 100-year flood plains, if applicable; and off-site flows through project.
 - B. Computations. Hydrologic and hydraulic computations including:
 - 1. Hydrologic and hydraulic parameter determination and source references
 - 2. Off-site and on-site historic runoff
 - 3. Off-site and on-site proposed-development runoff
 - 4. Street capacity calculations identifying depth and velocity for minor and major design storms
 - 5. Inlet and catch basin capacity calculations
 - 6. Open channel calculations with depth, velocity, HGL, and freeboard provided for minor and major design storms
 - 7. Detention volumes and release rates for the design storms. Copies of all tables, figures, charts, equations, etc. used for the analyses (with references)
 - 8. Storm drain hydraulic grade line (HGL) calculations for minor and major design storms
 - 9. Design calculations for all hydraulic structures
 - 10. Copies of all equations, tables, figures, charts, etc. used for the analyses (with references)
 - 11. Basin schematic showing connectivity between sub-basins, flow conveyance elements, and other pertinent modeling nodes
 - 12. Capacity analysis of off-site facilities
 - 13. Geotechnical information (as needed to support hydraulic design assumptions)
 - C. Drawings and Figures. Include Drainage Plan per Section 504.2 and any other figures developed for the report.

504.2 DRAINAGE PLAN

A detailed drainage plan(s) that addresses existing and proposed conditions for the subject site shall be submitted with the Technical Drainage Report. The plan(s) shall be on a 24" x 36" drawing at an appropriate legible scale (a scale of 1" = 50 to 1" = 500 is recommended). The following information shall be shown on this drawing, except that the off-site drainage basin boundaries may be shown at an appropriate legible scale on an exhibit.

1. Property lines (existing and proposed) and streets (roads) including right-of-way widths within 100 feet of the property.
2. Existing contours and proposed elevations sufficient to analyze drainage patterns extending a minimum of 100 feet outside of property lines.
3. Existing drainage facilities and structures, including ditches, storm sewers, channels, street flow directions, and culverts. All pertinent information such as material, size, shape, slope, and location shall also be included.
4. Limits of existing flood plains based on Flood Insurance Rate Maps, if available. Also, existing flood plains based on best available data (existing flood plain studies) should be shown where available.
5. Proposed on-site drainage basin boundaries with appropriate basin labels. Include off-site basin boundary intersections with on-site basin boundaries if not shown elsewhere. Label all design points.
6. Proposed future on-site and off-site flow directions and paths
7. Proposed street and ditch flow paths and slopes
8. Proposed storm drain locations, type, size, and slope. Include inlet types, sizes and locations, and manhole locations.
9. Proposed channel alignment with typical cross section. Include major storm flow limits.
10. Proposed culvert locations, type, size, and slope
11. Proposed On-site Drainage System outlet(s) to the Off-site Drainage System
12. Proposed Off-site Drainage System from site to Major Drainage System
13. Detention/retention facilities and related structures. Indicate extent and depth of ponding for design storms.
14. Miscellaneous proposed drainage facilities (e.g. hydraulic structures, erosion protection, etc.)
15. Details for special structures (e.g. detention pond outlets, overflow spillways, erosion protection, storm water quality improvements, etc.)
16. Table of minor and major storm peak flows including tributary area at critical design points and Rational Method design data (where used)
17. All Drainage and maintenance easement widths and boundaries
18. Labels of all inlets and manholes to correspond to tabular number system
19. Table of pipe sizes, grades, velocities, peak flows, and HGL
20. Legend for all symbols used on drawing
21. Reference to benchmark and USGS datum
22. Scale, North Arrow, Title Block, Professional Engineers Signature, Seal, Date

504.3 CALCULATIONS EXEMPTION

The report requirements for a Technical Drainage Report may be reduced at the request of the applicant or local entity, pending approval of the Jurisdictional Entities, if there is uncertainty over the final characteristics of the proposed drainage facilities. In such cases, the Technical Drainage Report shall identify all areas where the uncertainty exists and explain why final characteristics can not be presently determined. Hydrologic and hydraulic calculations based upon assumptions may then be provided with less detail. The Jurisdictional Entity may tentatively approve such interim reports based on design assumptions. The relevant analyses and designs shall be completed in the appropriate detail as part of the Technical Drainage Report Addendum which will be required to be submitted at the time of or prior to submittal of the final Improvement Plans. The Technical Drainage Report and Addendum will need to have final approval from the Jurisdictional Entity before the Improvement Plans can be approved.

504.4 IMPROVEMENT PLANS

Improvement Plans are desired but not required to be submitted with the Technical Drainage Report. However, profiles of storm sewers with HGLs and EGLs may be required for adequate review if required by the Jurisdictional Entity.

505 TECHNICAL DRAINAGE REPORT ADDENDUM

The purpose of the Technical Drainage Report Addendum is to provide all detailed hydrologic and hydraulic calculations which were not mentioned in the Technical Drainage Report requirements, or to present analysis and design changes made subsequent to the submittal and approval of a Technical Drainage Report. This addendum shall be prepared as required by the Jurisdictional Entity in accordance with the following outline and contain the applicable information listed:

- I. Title Page
 - A. Project Name, Type of Study, Study Date
 - B. Preparer's Name, Firm and Date
 - C. Professional Engineer's Seal and Signature
- II. Introduction. Discussion of the reason for submitting the Addendum and overview of the Addendum contents.
- III. Hydrologic and Hydraulic Analysis. Provide revised or additional analysis per the Technical Drainage Report requirements.
- IV. Conclusion. Present a summary of the information or modifications presented in this Addendum.
- V. References. Provide a list of all references used for the Addendum.
- VI. Appendices.
 - A. Include all relevant calculations, equations and models.
 - B. Include a revised Drainage Plan per the requirements of the Technical Drainage Report. The revised plan should contain all needed information to provide a replacement for the plan submitted with the original Technical Drainage Report.

506 IMPROVEMENT PLANS

Where drainage improvements are to be constructed, the final construction plans shall be submitted for approval. Approval of the final construction plans by the Jurisdictional Entity is a condition of issuing construction permits. The plans for the drainage improvements will include:

1. Storm sewers, inlets, outlets and manholes with pertinent elevations, dimensions, type, and horizontal control indicated
2. Culverts, end sections, and inlet/outlet protection with dimensions, type, elevations, and horizontal control indicated
3. Channels, ditches, and swales (including side/rear yard swales) with lengths, widths, cross-sections, grades and erosion control (i.e. riprap, concrete, grout) indicated
4. Checks, channel drops, erosion control facilities
5. Detention pond grading, low-flow channels, outlets, and landscaping
6. Other drainage related structures and facilities (including underdrains and sump pump lines)
7. EGLs and HGLs for minor (storm sewer) and major (channels) storm runoff
8. Maintenance access considerations
9. Overlot grading and erosion and sedimentation control facilities
10. Drainage easements and rights-of-way with horizontal distance to improvements
11. Drainage plan attached for information only

The information required for the plans shall be in accordance with sound engineering principles, this Manual, the Jurisdictional Entity's Development Code, and the uniform Standard Drawings and Standard Specifications for Public Works Construction. Construction documents shall include geometric, dimensional, structural, foundation, bedding, hydraulic, landscaping, and other details as needed to construct the drainage facility. The approved Drainage Plan shall be included as part of the construction documents for all facilities affected by the drainage plan. Construction plans shall be signed and sealed by a licensed professional engineer as being in accordance with the approved drainage report/drawings.

507 REQUIREMENTS FOR A FLOOD PLAIN STUDY

A study may be required at the discretion of the Jurisdictional Entity to ensure that property being developed is actually outside of a 100-year flood plain or is to be removed from the flood plain, that property removed from the flood plain and other properties that share frontage along the flood plain will not be adversely impacted, that the channel alignment will be stable and will not be subject to erosion which may threaten property, that sufficient conveyance capacity is maintained, and that the Jurisdictional Entity will comply with the requirements of FEMA for administering a flood plain management program. A Flood Plain Study is typically required for designating a flood plain for drainageways (as identified by the Jurisdictional Entity) where one has not been established or for modification of an existing flood plain that is delineated in a flood plain delineation study or on a FEMA Flood Insurance Rate Map (FIRM). Requirements for development in and adjacent to a drainageway vary by jurisdiction

The effort necessary for a Flood Plain Study is dependent upon the amount of information previously generated, the potential for impact on adjacent properties, the magnitude of flow in the channel, the

size of the area affected, the need for channel stabilization, and the sediment transport and fluvial morphological aspects of the stream. Flood Plain Studies are required for the following activities:

1. As an initial feasibility study to determine the potential utilization of a site with flood plain impacts.
2. To support a zoning case for establishment of a flood plain area for drainages that have not had the 100-year flood plain delineated.
3. To support a zoning case where a zone will be modified from an existing flood plain designation.
4. With a Conceptual and/or Technical Drainage Report where flood plain modifications are proposed.
5. For other agencies constructing highways, bridges, or other improvements which affect a FEMA designated flood plain.

507.1 OUTLINE FOR A FLOOD PLAIN STUDY

A Flood Plain Study must address the following points through actual analysis or through reference to adopted drainage master plans:

1. A description of the flood plain area (i.e. vegetation, condition, slope constrictions)
2. A description of the contributing drainage basin(s)
3. Identification of applicable flood plain studies and or Flood Insurance Studies with analysis of the applicability of data to the subject area
4. Hydrologic analysis
5. Characteristics of the proposed channel including but not limited to slope, roughness, depth, velocity, Froude number, centerline alignment and stationing, and cross sections. Existing topographic maps may be utilized if they are field verified to determine if changes have occurred. The profile and plan shall be given for existing conditions and for the proposed channel alignment including the cross section locations.
6. A description of the method of hydraulic analysis and its application in the study
7. Identification and discussion of all input parameters and basis for input parameters
8. Discussion of the results and conclusions of the hydraulic analysis. This shall include a narrative summary of the results as well as comprehensive output data.
9. The delineation of the existing and proposed 100-year flood plain and water surface profile. Include cross-section locations.
10. A description of impacts on other property owners along the flood plain
11. A conceptual design for the channel including embankment protection, drop structures, culverts, bridges, and the hardened low-flow channel
12. If appropriate, an analysis of sediment transport and fluvial morphology

507.2 FEMA DESIGNATED FLOOD PLAINS

In order for the Jurisdictional Entity to participate in the National Flood Insurance Program that is administered by FEMA, the Jurisdictional Entity must conduct a flood plain management program that complies with FEMA requirements. Thus all Flood Plain Studies that propose to change a FEMA

designated flood plain must address compliance with the FEMA requirements for the project. This includes federal regulations published in 44CFR Part 65 on technical and submittal requirements for a Letter of Map Revision.

The Jurisdictional Entity is required to make submittals for map revisions to FEMA for projects which propose floodway revisions and for developments which desire a change in the flood plain boundaries. For these cases, the applicant shall prepare the FEMA submittal packages and provide the FEMA review fee. The Flood Plain Study shall include a proposed schedule for obtaining a Letter of Map Revision for the project. The schedule shall include anticipated dates for:

- a. Submittal of the Conditional Letter of Map Revision FEMA submittal package to the Jurisdictional Entity for review.
- b. Submittal of the Conditional Letter of Map Revision submittal package to FEMA from the Jurisdictional Entity. A minimum 30-day review time is required for the Jurisdictional Entity to review the submittal.
- c. Issuance by FEMA of a Conditional Letter of Map Revision. FEMA approval is required before the Jurisdictional Entity issues permits for construction for areas within a flood plain.
- d. Submittal of a draft FEMA submittal package including as-built data for the Letter of Map Revision for review by the Jurisdictional Entity.
- e. The submittal of the Letter of Map Revision submittal package to FEMA by the Jurisdictional Entity. A minimum 30-day review time is required for the Jurisdictional Entity's review of the submittal.
- f. Issuance by FEMA of a Letter of Map Revision. FEMA approval is required before the Jurisdictional Entity grants final acceptance of public improvements in a subdivision.

The report should be prepared using the drawing size, map scale, and engineer certification requirements that are given for the Technical Drainage Report.

1. A pre-application consultation with the Jurisdictional Entity is suggested of all applicants for these processes. Information gained at said consultations may allow the Jurisdictional Entity to focus the applicant on those areas of significant drainage concerns, thus potentially lessening the applicant's time for submittal and subsequent revisions.
2. For all applications which include proposed modifications to areas within a designated 100-year flood plain, a Flood Plain Report shall also be submitted or incorporated into the Conceptual and/or Technical Drainage Report.
3. For all applications which include proposed modifications to a natural drainageway for which a 100-year flood plain has not been designated, a Flood Plain Report shall also be submitted or incorporated into the Conceptual and/or Technical Drainage Report.
4. If drainage improvements are required to be constructed as part of this project, a Technical Drainage Report and Improvement Plan will be required to be submitted for said drainage improvements.
5. Comments received on the Conceptual Drainage Report during the tentative review process shall be addressed in the Technical Drainage Report.
6. If not waived per the result of a pre-application consultation, a Conceptual Drainage Report will be required if:

- a) Amendment area is within a 100-year flood plain, or
 - b) Amendment area housing/development density will increase over that already included in the plan.
7. No submittals are required if lot is part of an approved subdivision, parcel map, or map of division into large parcels. A Technical Drainage Report is required if a grading permit is required.
8. A Conceptual Drainage Report may be allowed for areas with minimal drainage impacts upon prior approval of the Jurisdictional Entity.

REQUIRED DRAINAGE REPORT SUBMITTALS

TYPE OF PROCESS/PROJECT	DRAINAGE REPORT REQUIREMENT	COMMENTS
Rezoning	May be required in special cases	1, 2, 3
Tentative Map of Division into Large Parcels	Required by condition	1, 2, 3, 4
Tentative Parcel Map	Required by condition	1, 2, 3, 4
Subdivision Map <ul style="list-style-type: none"> • Tentative • Final 	Conceptual Technical	1, 2, 3 5, 8
Grading Permit <ul style="list-style-type: none"> • For grading of subdivision and parcel map areas prior to final approval and for all other grading activities 	Technical	1, 2, 3, 4, 8
Public Works Projects	Technical	1, 2, 3, 8
Special Use Permit	Conceptual	1, 2, 3, 4
Plan Amendment	See Comments	1, 6
Site Plan Review <ul style="list-style-type: none"> • Single Family • All Other 	See Comments Technical	7 1, 2, 3, 8

COMMENTS

1. A pre-application consultation with appropriate Jurisdictional Entity is suggested of all applicants for these processes. Information gained at said consultations may allow the Jurisdictional Entity to focus the applicant on those areas of significant drainage concerns, thus potentially lessening the applicant's time for submittal and subsequent revisions.
2. For all applications which include proposed modifications to areas within a designated 100-year flood plain, a Flood Plain Report shall also be submitted or incorporated into the Conceptual and/or Technical Drainage Report.
3. For all applications which include proposed modifications to a natural drainageway for which a 100-year flood plain has not been designated, a Flood Plain Report shall also be submitted or incorporated into the Conceptual and/or Technical Drainage Report.
4. If drainage improvements are required to be constructed as part of this project, a Technical Drainage Report and Improvement Plans will be required to be submitted with the development application.
5. Comments received on the Conceptual Drainage Report during the tentative review process shall be addressed in the Technical Drainage Report.
6. If not waived per the result of a pre-application consultation, a Conceptual Drainage Report will be required if:
 - a) Amendment area is within a 100-year flood plain, or
 - b) Amendment area housing/development density will increase over that already included in the plan.
7. No submittals required if lot is part of an approved subdivision, parcel map, or map of division into large parcels. A Technical Drainage Report is required if a grading permit is required.
8. A Conceptual Drainage Report may be allowed for areas with minimal drainage impacts upon prior approval of the Jurisdictional Entity.

VERSION: April 30, 2009

REFERENCE:

TABLE
501

WTC ENGINEERING INC

SECTION 600 - RAINFALL

TABLE OF CONTENTS

	<u>Page</u>
601 INTRODUCTION	601
602 RAINFALL	601
602.1 RAINFALL FOR CITY OF RENO AND UNINCORPORATED WASHOE COUNTY	601
602.2 RAINFALL FOR CITY OF SPARKS.....	601
603 RAINFALL DISTRIBUTION FOR SCS UNIT HYDROGRAPH METHOD.....	601
603.1 RAINFALL DEPTH - DURATION – FREQUENCY SOURCE	601
603.2 RAINFALL DEPTHS FOR DURATIONS FROM 5 MINUTES TO 24 HOURS	601
603.3 DEPTH-AREA REDUCTION FACTORS.....	602
604 RAINFALL DISTRIBUTION FOR RATIONAL METHOD.....	602
604.1 RAINFALL REGIONS FOR RATIONAL METHOD.....	602
604.2 TIME-INTENSITY-FREQUENCY CURVES IN REGION 1.....	603
604.3 TIME-INTENSITY-FREQUENCY CURVES IN REGION 2.....	603
604.4 TIME-INTENSITY-FREQUENCY CURVES IN REGION 3.....	603

LIST OF TABLES

601	CITY OF SPARKS RAINFALL DEPTH-DURATION-FREQUENCY DATA, REGION 1
602	CITY OF SPARKS RAINFALL DEPTH-DURATION-FREQUENCY DATA, REGION 2
603	CITY OF SPARKS RAINFALL DEPTH-DURATION-FREQUENCY DATA, REGION 3

LIST OF FIGURES

601	CITY OF SPARKS REGION BOUNDARIES
602	CITY OF SPARKS RAINFALL INTENSITY DURATION FREQUENCY CURVE, REGION 1
603	CITY OF SPARKS RAINFALL INTENSITY DURATION FREQUENCY CURVE, REGION 2
604	CITY OF SPARKS RAINFALL INTENSITY DURATION FREQUENCY CURVE, REGION 3
605	CITY OF SPARKS DEPTH-AREA REDUCTION CURVE
606	EXAMPLE: HEC-1 INPUT AND OUTPUT FOR BASIN A

SECTION 600

RAINFALL

601 INTRODUCTION

Presented in this section is the design rainfall data for the Minor and Major storm events as designated in Section 304.2. This data is used to determine storm runoff in conjunction with the runoff models designated in Section 304.3. All hydrologic analysis within the jurisdiction of this Manual shall utilize the rainfall data presented herein for calculating storm runoff.

The methodology used to generate the rainfall data will depend on the size of the drainage basin to be studied. The Rational Method for determining runoff is widely accepted as providing a sufficient level of detail for generating runoff from relatively small basins (area ≤ 100 acres). The Rational Method utilizes rainfall data in the form of time-intensity-frequency curves.

Since the assumptions used in the Rational Method become less valid over larger areas, larger basins (area ≥ 100 acres) require a more rigorous analysis to generate runoff data. The HEC-1 or HEC-HMS computer model developed by the U.S. Army Corps of Engineers is a commonly used model that generates storm runoff (USACE, 1990A). The rainfall data used in this model will be a centrally distributed storm event with depths at time intervals of 5 minutes, 15 minutes, 60 minutes, 2 hours, 3 hours, 6 hours, 12 hours, and 24 hours.

602 RAINFALL

602.1 RAINFALL FOR CITY OF RENO AND UNINCORPORATED WASHOE COUNTY

NOAA Atlas 14 (at www.nws.noaa.gov/ohd/hdsc/) is to be used for rainfall in the City of Reno and the unincorporated areas of Washoe County. A 24-hr storm duration shall be the standard design storm duration for hydrologic methods other than the Rational Method.

602.2 RAINFALL FOR CITY OF SPARKS

The remainder of Section 600 is based on the National Weather Service's Southwest Semiarid Precipitation Frequency Study (SSPFS, 1997), and is for use in the City of Sparks.

603 RAINFALL DISTRIBUTION FOR SCS UNIT HYDROGRAPH METHOD

603.1 RAINFALL DEPTH - DURATION – FREQUENCY SOURCE

The National Weather Service's Southwest Semiarid Precipitation Frequency Study (SSPFS, 1997) has developed six (6) rainfall depth maps for the 1-, 6-, and 24-hour storm durations for the 2-, and 100-year recurrence frequency. Maps were utilized to develop the rainfall for the three regions in the City of Sparks and are included at the end of this Section.

603.2 RAINFALL DEPTHS FOR DURATIONS FROM 5 MINUTES TO 24 HOURS

The City of Sparks has been divided into three (3) regions based on the National Weather Service's Southwest Semiarid Precipitation Frequency Study (SSPFS, 1997). These regions are shown in Figure

601. Contributing “watersheds” may be located within more than one region. In this instance, each sub-basin will reflect the region in which it is located. For sub-basins located within more than one region, the region in which the majority of the sub-basin lies will be used.

The rainfall distribution for a 24-hour storm at time intervals of 5 minutes, 15 minutes, 1 hour, 2 hours, 3 hours, 6 hours, 12 hours, and 24 hours for the desired recurrence frequency will be used in HEC-1 or HEC-HMS models. The rainfall distribution is centered around the midpoint of the design storm (time = 12 hours). These rainfall values are input into the HEC-1 or HEC-HMS program using the PH record. When using the PH record in conjunction with the JR record for watersheds that are more than 2 square miles in total area, a value of 0.001 should be input into Field 2 to prevent the program from using an internal point rainfall reduction adjustment (see Section 606.3). A sample HEC-1 input and output that uses a tabulation interval of 5 minutes and 300 hydrograph ordinates is shown in Figure 606 shows a tabulation interval of 5 minutes and 300 hydrograph ordinates. For smaller basins, a tabulation interval of 2 to 3 minutes will be used.

603.3 DEPTH-AREA REDUCTION FACTORS

The SSPFS precipitation depths are related to rainfall frequency at an isolated point. Storms, however, cause rainfall to occur over extensive areas simultaneously, with more intense rainfall typically occurring near the center of the storm. Standard precipitation analysis methods require adjusting point precipitation depths downward in order to estimate the average depth of rainfall over the entire storm area. This is normally performed using depth-area reduction curves relating point precipitation reduction factor to drainage basin area and duration.

For watersheds that are less than 2 square miles in total area, Figure 605 shows that the depth-area reduction is less than 1% and is not significant. In this case, a 0 may be entered in Field 2 of the JR card to default to using the basin area to compute the reduction of point rainfall depths. For watersheds that are greater than 2 square miles in total area, Figure 605 provides the depth-area reduction curve for the 24-hour storm event (NOAA, 1973). Depth-area values are input to the HEC-1 or HEC-HMS program using the JR record. The peak flow value at a given point should be determined using the depth-area value for the total watershed area tributary to the subject point of interest.

The ability of the thunderstorm generating mechanisms (i.e. available moisture, strong convective currents, etc.) to sustain a thunderstorm greater than 200 square miles is greatly reduced. Therefore, only a portion of an entire drainage basin could be subject to precipitation from the thunderstorm event. Analysis of this effect on runoff peaks and volumes is complicated by the necessity to determine the "storm centering" which produces the greatest peak flow and/or volume at the selected design point. Thus, in order to obtain a consistent method of analysis for drainage basins larger than 200 square miles, the designer shall consult with the Jurisdictional Entity to determine the appropriate method of analysis for the specific location and basin under consideration.

604 RAINFALL DISTRIBUTION FOR RATIONAL METHOD

604.1 RAINFALL REGIONS FOR RATIONAL METHOD

A review of the isopluvial maps generated by the SSPFS indicates that, for the Rational Method analysis, the City of Sparks can be divided into three rainfall zones. Within each zone, the precipitation values were similar for the various return periods and duration storms. Rainfall depths and intensities for these regions are shown in Tables 601 through 603.

If more than 50 percent of the basin lies in a given region, the rainfall data for that region shall be used. Basin area refers to the actual basin or sub-basin for which storm runoff information is being calculated and not necessarily the entire watershed area.

604.2 TIME-INTENSITY-FREQUENCY CURVES IN REGION 1

Within Region 1, the rainfall time-intensity-frequency curves used in the Rational Method are assumed to be identical throughout the zone. The curves are shown in Figure 602, and tabulated in Table 601.

604.3 TIME-INTENSITY-FREQUENCY CURVES IN REGION 2

Within Region 2, the rainfall time-intensity-frequency curves used in the Rational Method are assumed to be identical throughout the zone. The curves are shown in Figure 603, and tabulated on Table 602.

604.4 TIME-INTENSITY-FREQUENCY CURVES IN REGION 3

Within Region 3, the rainfall time-intensity-frequency curves used in the Rational Method are assumed to be identical throughout the zone. The curves are shown in Figure 604, and tabulated on Table 603.

References

SSPFS, 1997 - *Precipitation Frequency Study of the United States*, (NOAA Atlas 14, Volume 1 - Semi-Arid Southwest United States [Draft Maps], April 1997).

**CITY OF SPARKS
RAINFALL DEPTH - DURATION - FREQUENCY DATA
REGION 1**

DEPTH (inches)

Return Period (Yr.)	5 min	10 min	15 min	30 min	1 hr	2 hr	3 hr	6 hr	12 hr	24 hr
2 yr	0.11	0.16	0.20	0.27	0.33	0.44	0.52	0.70	0.88	1.06
5 yr	0.15	0.22	0.27	0.37	0.45	0.59	0.69	0.91	1.13	1.36
10 yr	0.19	0.28	0.34	0.47	0.57	0.72	0.83	1.06	1.33	1.59
25 yr	0.25	0.38	0.46	0.63	0.77	0.92	1.03	1.27	1.58	1.90
50 yr	0.32	0.47	0.58	0.79	0.96	1.10	1.21	1.43	1.78	2.13
100 yr	0.39	0.59	0.72	0.98	1.19	1.31	1.40	1.58	1.97	2.35

INTENSITY (in/hr)

Return Period (Yr.)	5 min	10 min	15 min	30 min	1 hr	2 hr	3 hr	6 hr	12 hr	24 hr
2 yr	1.31	0.97	0.79	0.54	0.33	0.22	0.17	0.12	0.07	0.04
5 yr	1.78	1.32	1.08	0.74	0.45	0.29	0.23	0.15	0.09	0.06
10 yr	2.25	1.67	1.36	0.93	0.57	0.36	0.28	0.18	0.11	0.07
25 yr	3.03	2.25	1.84	1.26	0.77	0.46	0.34	0.21	0.13	0.08
50 yr	3.80	2.82	2.30	1.57	0.96	0.55	0.40	0.24	0.15	0.09
100 yr	4.73	3.51	2.87	1.96	1.19	0.66	0.47	0.26	0.16	0.10

VERSION: April 30, 2009	REFERENCE: NOAA Semi-arid Precipitation Study - Nevada, 1997	TABLE 601
WTC ENGINEERING, INC.		

**CITY OF SPARKS
RAINFALL DEPTH - DURATION - FREQUENCY DATA
REGION 2**

DEPTH (inches)

Return Period (Yr.)	5 min	10 min	15 min	30 min	1 hr	2 hr	3 hr	6 hr	12 hr	24 hr
2 yr	0.12	0.17	0.21	0.29	0.35	0.45	0.53	0.70	0.88	1.06
5 yr	0.16	0.23	0.29	0.39	0.48	0.61	0.70	0.91	1.13	1.36
10 yr	0.20	0.29	0.36	0.49	0.60	0.74	0.85	1.06	1.33	1.59
25 yr	0.27	0.40	0.49	0.67	0.81	0.95	1.05	1.27	1.58	1.90
50 yr	0.34	0.50	0.61	0.84	1.02	1.14	1.23	1.43	1.78	2.13
100 yr	0.42	0.62	0.76	1.04	1.27	1.36	1.43	1.58	1.97	2.35

INTENSITY (in/hr)

Return Period (Yr.)	5 min	10 min	15 min	30 min	1 hr	2 hr	3 hr	6 hr	12 hr	24 hr
2 yr	1.39	1.03	0.84	0.57	0.35	0.23	0.18	0.12	0.07	0.04
5 yr	1.88	1.40	1.14	0.78	0.48	0.30	0.23	0.15	0.09	0.06
10 yr	2.38	1.77	1.44	0.99	0.60	0.37	0.28	0.18	0.11	0.07
25 yr	3.22	2.39	1.95	1.33	0.81	0.47	0.35	0.21	0.13	0.08
50 yr	4.03	2.99	2.44	1.67	1.02	0.57	0.41	0.24	0.15	0.09
100 yr	5.02	3.72	3.04	2.08	1.27	0.68	0.48	0.26	0.16	0.10

VERSION: April 30, 2009

WJC ENGINEERING, INC.

REFERENCE:

NOAA Semi-arid Precipitation Study - Nevada, 1997

TABLE
602

**CITY OF SPARKS
RAINFALL DEPTH - DURATION - FREQUENCY DATA
REGION 3**

DEPTH (inches)

Return Period (Yr.)	5 min	10 min	15 min	30 min	1 hr	2 hr	3 hr	6 hr	12 hr	24 hr
2 yr	0.13	0.19	0.23	0.31	0.38	0.48	0.55	0.71	0.89	1.07
5 yr	0.17	0.25	0.31	0.42	0.52	0.64	0.73	0.92	1.15	1.37
10 yr	0.22	0.32	0.39	0.54	0.65	0.78	0.88	1.08	1.34	1.61
25 yr	0.29	0.43	0.53	0.72	0.88	1.00	1.09	1.29	1.60	1.92
50 yr	0.36	0.54	0.66	0.91	1.11	1.21	1.29	1.45	1.80	2.15
100 yr	0.45	0.67	0.83	1.13	1.38	1.44	1.50	1.60	1.99	2.38

INTENSITY (in/hr)

Return Period (Yr.)	5 min	10 min	15 min	30 min	1 hr	2 hr	3 hr	6 hr	12 hr	24 hr
2 yr	1.50	1.12	0.91	0.62	0.38	0.24	0.18	0.12	0.07	0.04
5 yr	2.05	1.52	1.24	0.85	0.52	0.32	0.24	0.15	0.10	0.06
10 yr	2.59	1.92	1.57	1.07	0.65	0.39	0.29	0.18	0.11	0.07
25 yr	3.49	2.59	2.12	1.45	0.88	0.50	0.36	0.21	0.13	0.08
50 yr	4.38	3.25	2.65	1.81	1.11	0.60	0.43	0.24	0.15	0.09
100 yr	5.45	4.04	3.30	2.26	1.38	0.72	0.50	0.27	0.17	0.10

VERSION: April 30, 2009

WTC ENGINEERING, INC.

REFERENCE:

NOAA Semi-arid Precipitation Study - Nevada, 1997

TABLE
603

CITY OF SPARKS - REGION BOUNDARIES

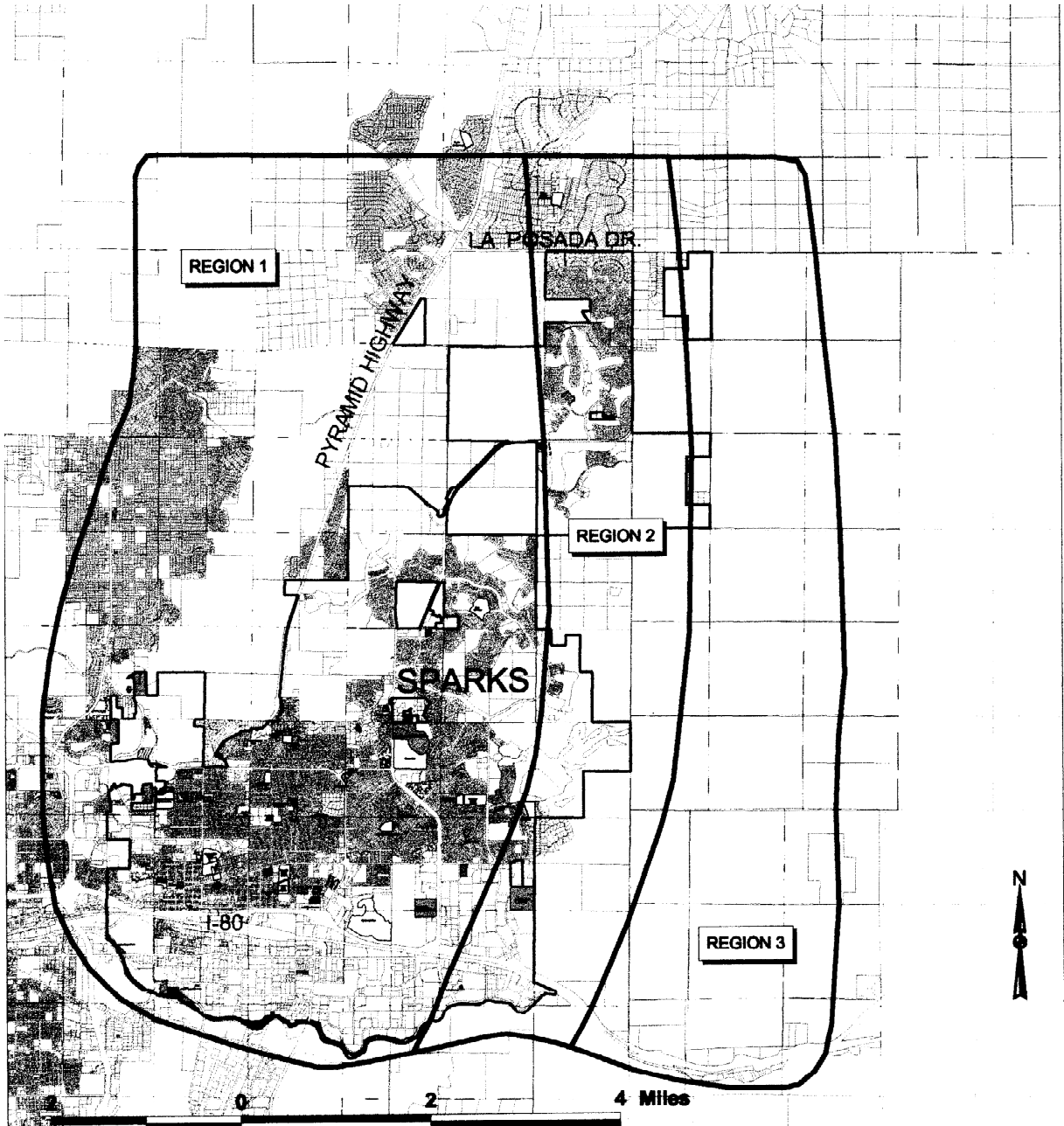

VERSION: April 30, 2009	REFERENCE: NOAA Semi-arid Precipitation Study – Nevada 1997	FIGURE 601
WTC ENGINEERING, INC		

**CITY OF SPARKS
RAINFALL INTENSITY DURATION FREQUENCY CURVE – REGION 1**

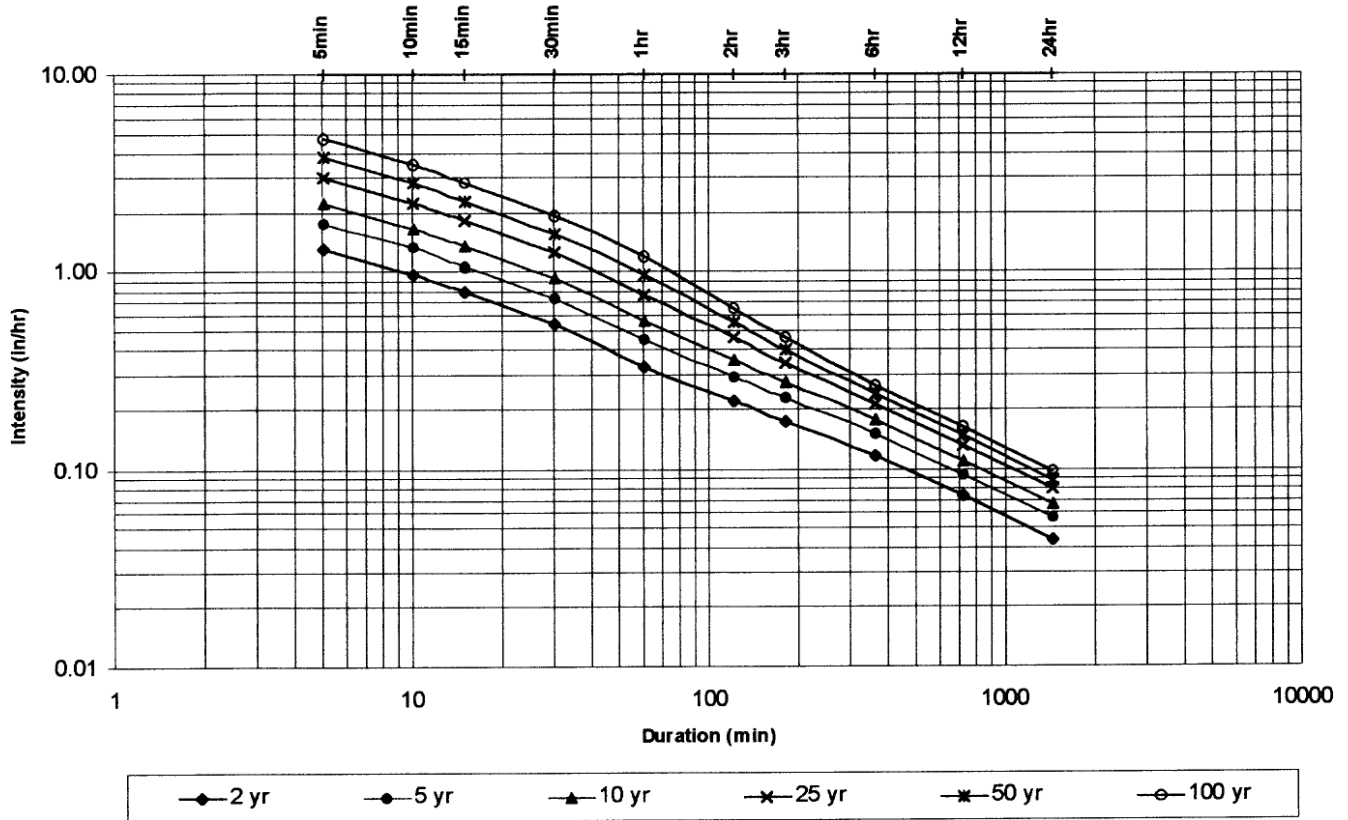

VERSION: April 30, 2009

WTC ENGINEERING, INC.

REFERENCE:
NOAA Semi-arid Precipitation Study –
Nevada 1997

FIGURE
602

**CITY OF SPARKS
RAINFALL INTENSITY DURATION FREQUENCY CURVE – REGION 2**

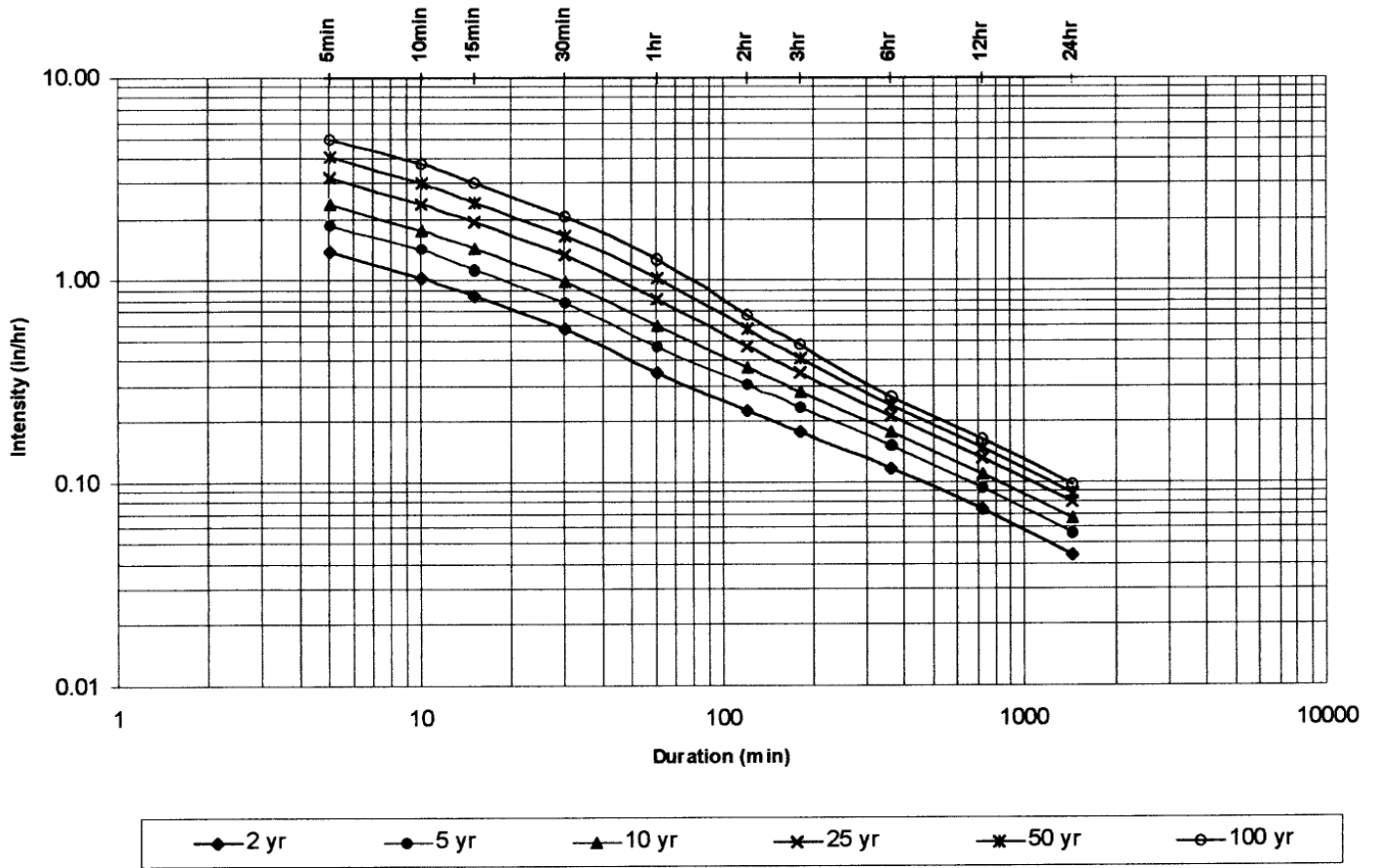

VERSION: April 30, 2009	REFERENCE: NOAA Semi-arid Precipitation Study – Nevada 1997	FIGURE 603
W7C ENGINEERING, INC.		

**CITY OF SPARKS
RAINFALL INTENSITY DURATION FREQUENCY CURVE – REGION 3**

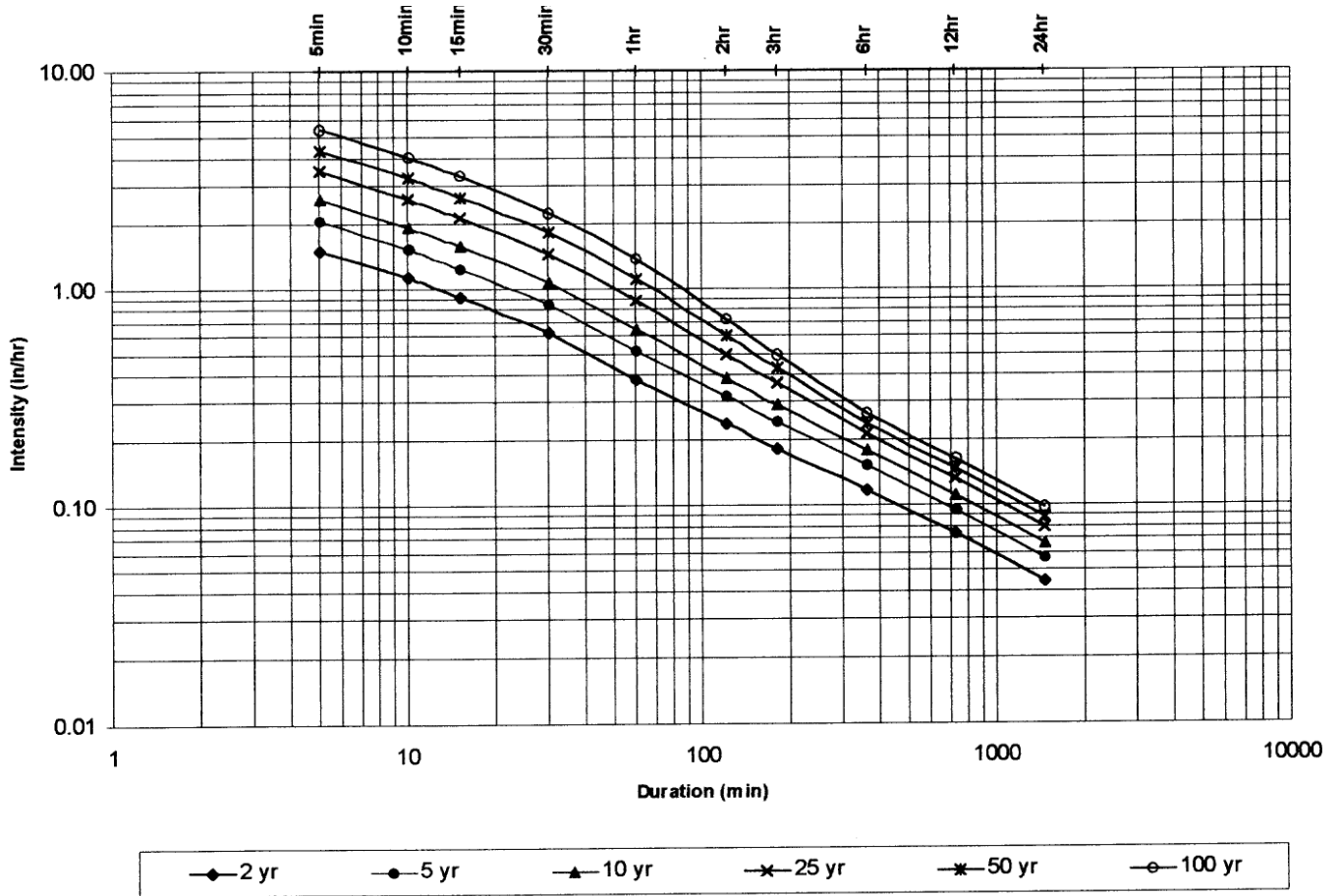

VERSION: April 30, 2009

WTC ENGINEERING, INC.

REFERENCE:
NOAA Semi-arid Precipitation Study –
Nevada 1997

FIGURE
604

CITY OF SPARKS

DEPTH-AREA REDUCTION CURVE

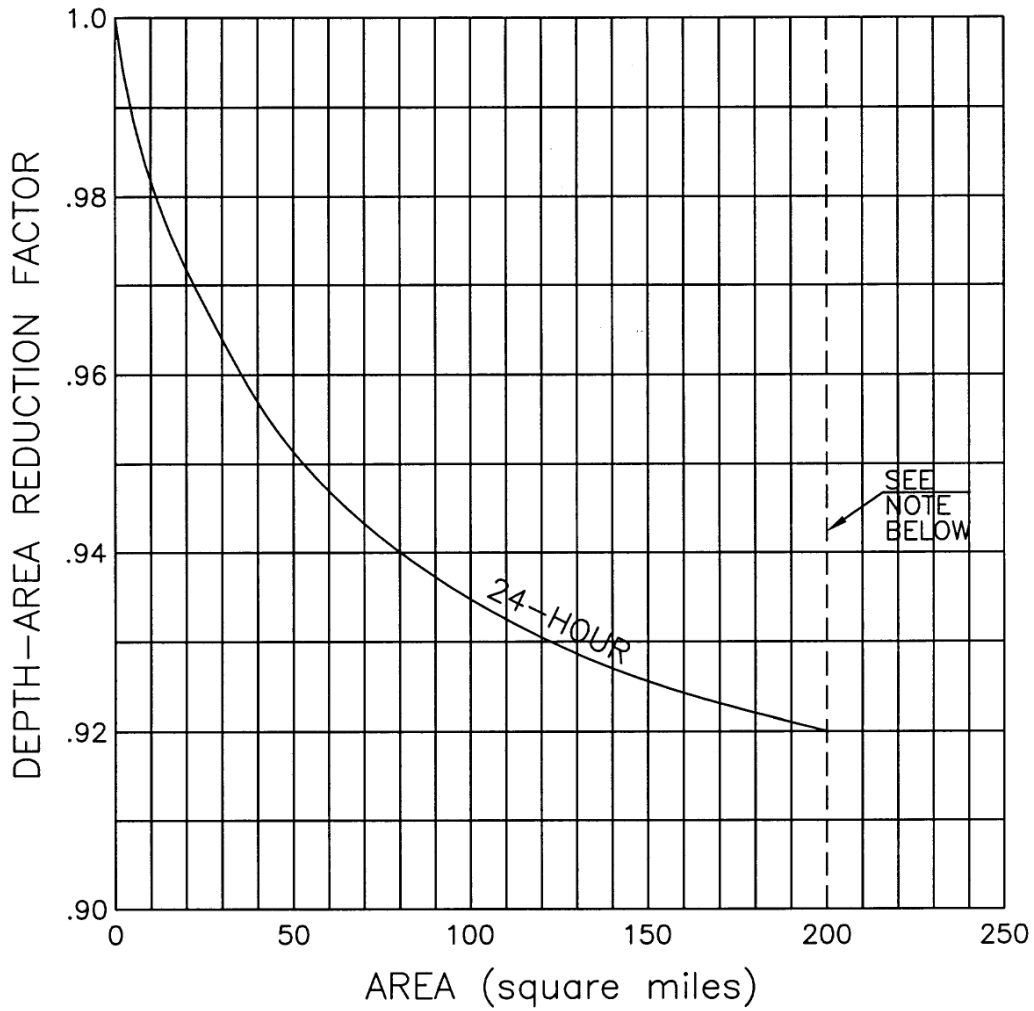

Note: Consult with the Jurisdictional Entity for guidance in using the depth-area reduction factors and storm centering for modeling of drainage areas greater than 200 square miles.

VERSION: April 30, 2009	REFERENCE: U.S. Department of Commerce, NOAA Atlas No. 2, 1973	FIGURE 605
WTC ENGINEERING, INC.		

EXAMPLE: HEC-1 INPUT AND OUTPUT FOR BASIN A

1 HEC-1 INPUT

LINE	ID	1	2	3	4	5	6	7	8	9	10
1	ID	CITY OF SPARKS DRAINAGE CRITERIA MANUAL EXAMPLE									
2	ID	DOE CREEK									
3	ID	24-HR, 100-YEAR EVENT									
4	ID	WRC NEVADA, INC.									
5	IT	5		0		300					
6	IO	2									
7	JR	PREC	.995								
8	KK	A	BASIN A HYDROGRAPH								
9	BA	3.34									
10	LS	0	61								
11	PH		.001	.48	.87	1.45	1.69	1.88	2.26	2.91	3.55
12	UD	2.05									
13	ZZ										

HEC-1 OUTPUT

PEAK FLOW AND STAGE (END-OF-PERIOD) SUMMARY
 FOR MULTIPLE PLAN-RATIO ECONOMIC COMPUTATION
 FLOWS IN CUBIC FEET PER SECOND, AREA IN SQUARE MILES
 TIME TO PEAK IN HOURS

OPERATION	STATION	AREA	PLAN	RATIO 1
				1.00
HYDROGRAPH AT				
+	A	3.34	1	FLOW 191
				TIME 14.58

NORMAL END OF HEC-1

VERSION: April 30, 2009	REFERENCE:	FIGURE
WRC ENGINEERING, INC.	HEC-1	606

SECTION 700 - STORM RUNOFF

TABLE OF CONTENTS

	<u>Page</u>
701 INTRODUCTION	702
701.1 BASIN CHARACTERISTICS	702
702 TIME OF CONCENTRATION	702
702.1 URBANIZED BASINS	703
703 PRECIPITATION LOSSES	704
703.1 INTRODUCTION	704
703.2 SCS CURVE NUMBER METHOD	705
704 RATIONAL FORMULA METHOD	706
704.1 METHODOLOGY	706
704.2 ASSUMPTIONS	707
704.3 LIMITATIONS ON METHODOLOGY	707
704.4 RAINFALL INTENSITY	707
704.5 RUNOFF COEFFICIENT	707
704.6 APPLICATION OF THE RATIONAL FORMULA METHOD	708
704.7 MAJOR STORM ANALYSIS	708
705 SCS UNIT HYDROGRAPH METHOD	708
705.1 METHODOLOGY	708
705.2 ASSUMPTIONS	709
705.3 LAG TIME	709
705.4 UNIT STORM DURATION	710
705.5 SUB-BASIN SIZING	710
706 CHANNEL ROUTING OF HYDROGRAPHS	711
707 RESERVOIR ROUTING OF HYDROGRAPHS	711
707.1 MODIFIED PULS METHOD	712
708 STATISTICAL ANALYSIS	712
709 VOLUME OF RUNOFF AND STORAGE VOLUMES	713
709.1 GENERAL	713
709.2 NORTH VALLEYS (CITY OF RENO AND WASHOE COUNTY ONLY)	713
709.3 FLOOD PLAIN STORAGE WITHIN THE TRUCKEE RIVER WATERSHED	714
710 GREEN AND APMT METHOD (PLACEHOLDER FOR FUTURE SECTION)	714
711 EXAMPLE APPLICATIONS	714
711.1 EXAMPLE: RATIONAL FORMULA METHOD	714
711.2 EXAMPLE: SCS UNIT HYDROGRAPH METHOD	716

LIST OF TABLES

- 701 RATIONAL FORMULA METHOD RUNOFF COEFFICIENTS
- 702 RUNOFF CURVE NUMBERS
- 703 LAG EQUATION ROUGHNESS FACTORS
- 704 EXAMPLE: RATIONAL FORMULA METHOD RESULTS

LIST OF FIGURES

- 701 TRAVEL TIME VELOCITY
- 702 PERCENTAGE OF IMPERVIOUS AREA VS. COMPOSITE CNs FOR GIVEN PERVIOUS AREA CNs
- 703 PROPOSED ROSE SUBDIVISION
- 704 EXAMPLE: HEC-1 INPUT AND OUTPUT DATA FOR BASIN A

SECTION 700

STORM RUNOFF

701 INTRODUCTION

For the area within the jurisdiction of this Manual, two deterministic hydrological models can be used to predict storm runoff (Policy Section 304). These models are the Rational Formula Method and the Soil Conservation Service, U.S. Department of Agriculture (SCS) Unit Hydrograph method. The procedures for using these methods are presented in this section. The Rational Formula Method may be employed without the use of computers. Computer modeling using the U.S. Army Corps of Engineers HEC-1 or HEC-HMS Flood Hydrograph Package or other hydrologic computer modeling programs is required for the SCS method. For certain circumstances, where adequate recorded stream flow data are available and the drainage area is large (> 10 square miles), a statistical analysis may be required to predict the storm runoff peaks or for calibration of deterministic models (see Section 708).

701.1 BASIN CHARACTERISTICS

The basin characteristics needed for the subject runoff computation methods include the drainage area, soil type, the various flow path lengths, slopes, and characteristics (i.e., overland, grassed channel, gutter) and land use types. The drainage basin boundary and area may be determined from available topographic maps or site-specific mapping depending upon the level of detail required. A field investigation is recommended to verify drainage boundaries. The land use and flow path characteristics can be obtained from zoning maps, aerial photographs, field investigations, or detailed topographic maps.

702 TIME OF CONCENTRATION

The definition of the time of concentration, t_c , for the purpose of this Manual, is the time required for water to flow from the hydraulically most distant part of the drainage area to the point under consideration. For the Rational Formula Method, the time of concentration must be estimated so that the average rainfall rate for the corresponding duration can be determined from the rainfall intensity-duration-frequency curves. For the SCS Unit Hydrograph method, the time of concentration is used to determine the time-to-peak, t_p , of the unit hydrograph and subsequently, the peak runoff.

In the past, several different time of concentration equations have been used with the runoff methods discussed in the following sections. However, as both methods have the same definition of the time of concentration, and to promote consistency between the two runoff methods, the time of concentration equations presented in this section shall be used for all watersheds of total area less than one square mile and whose basin slope is less than ten percent. For larger watersheds and for watersheds with basin slopes equal to or greater than ten percent, the basin lag equation shall be used (see Section 705.3).

For urban areas, the time of concentration consists of an inlet time or overland flow time (t_i) plus the time of travel (t_t) in the storm sewer, paved gutter, roadside drainage ditch, or drainage channel. For non-urban areas, the time of concentration consists of an overland flow time (t_i) plus the time of travel in a combined form, such as a small swale, channel, or wash. The latter portion (t_t) of the time of concentration can be estimated from the hydraulic properties of the storm sewer, gutter, swale, ditch, or wash. Inlet time, on the other hand, will vary with surface slope, depression storage, surface cover,

antecedent rainfall, and infiltration capacity of the soil, as well as distance of surface flow. Thus, the time of concentration for both urban and non-urban areas shall be calculated as follows:

$$t_c = t_i + t_t \quad (701)$$

In which t_c = time of concentration (minutes)
 t_i = initial, inlet, or overland flow time (minutes)
 t_t = travel time in the ditch, channel, gutter, storm sewer, etc. (minutes)

To aid in the computation of t_c , Standard Form 2 (see Section - 1500) has been developed to organize the computation. In all drainage studies, t_c calculations should be submitted using Standard Form 2.

The initial or overland flow time, t_i , may be calculated using the following equation:

$$t_i = \frac{1.8 (1.1 - R) L_o^{1/2}}{S^{1/3}} \quad (702)$$

Where t_i = initial or overland flow time (minutes)
 R = flow runoff coefficient
 L_o = length of overland flow (feet, 500 feet maximum)
 S = average overland basin slope (percent)

Equation 702 was originally developed by the Federal Aviation Administration (FAA, 1970) for use with the Rational Formula Method. However, the equation is also valid for computation of the initial or overland flow time for the SCS Unit Hydrograph method using the appropriate flow runoff coefficient.

For the Rational Formula Method, the 5-year runoff coefficient, C_5 , presented in Table 701 shall be used as the flow runoff coefficient, R . For the SCS Unit Hydrograph method, R shall be calculated using the following equation:

$$R = .0132 CN - 0.39 \quad (703)$$

This equation was developed by converting CN factors to typical C_5 runoff coefficients.

The overland flow length, L_o , is generally defined as the length of flow over which the flow characteristics appear as sheet flow or very shallow flow in grassed swales. Changes in land slope, surface characteristics, and small drainage ditches or gullies will tend to force the overland flow into a concentrated flow condition. Thus, the initial flow time would generally end at these locations.

For longer basin lengths, initial or overland flow needs to be considered in combination with the travel time, t_t , which is calculated using the hydraulic properties of the swale, ditch, or channel. For preliminary work, travel time can be estimated with the help of Figure 701 (SCS, 1985). The time of concentration is then the sum of the initial flow time, t_i and the travel time t_t (Equation 701). The minimum t_c in Washoe County for non-urban watersheds shall be 10 minutes.

702.1 URBANIZED BASINS

Overland flow in urbanized basins can occur from the back of the lot to the street, in parking lots, in greenbelt areas, or within park areas. It can be calculated using the procedure described in Section 702 except that the travel time, t_t , to the first design point or inlet is estimated using the "Paved Area (Sheet Flow) & Shallow Gutter Flow" line in Figure 701. The time of concentration for the first design point in an urbanized basin using this procedure should not exceed the time of concentration

calculated using Equation 704, which was developed using rainfall/runoff data collected in urbanized regions (USDCM, 1969).

$$t_c = L/180 + 10 \quad (704)$$

Where t_c = time of concentration at the first design point in an urban watershed (minutes)

L = watershed length (feet)

Equation 704 may result in a lesser time of concentration at the first design point and thus would govern in an urbanized watershed. For subsequent design points, the time of concentration is calculated by accumulating the travel times in downstream reaches. The minimum t_c for urbanized paved areas shall be 5 minutes and 10 minutes for vegetated landscaped areas.

A common mistake in calculating t_c is to assume travel velocities (for t_t) that are too small or not using post development slopes. Another common error is to not analyze the portion of basin which would result in the longest computed time of concentration. This error is most often encountered in long basins, or a basin where the upper portion contains grassy park land and the lower developed urban land. However, a check should be performed to assure that calculated runoff from the total area is not exceeded by calculated runoff from only the urbanized area.

When performing hydrologic calculations for proposed conditions, the overland flow path should be taken perpendicular to the proposed, and not preexisting, contours. Additionally, the time of concentration calculation should utilize the flow path defined by the proposed improvements which act to intercept storm flows.

703 PRECIPITATION LOSSES

Precipitation loss calculations are required for the SCS Unit Hydrograph method. The calculation methodology for precipitation losses within Washoe County is presented in the following section. For the Rational Formula Method, the precipitation losses are not computed separately. Therefore, the following methodology does not apply to the Rational Formula Method.

703.1 INTRODUCTION

Land surface interception, depression storage and infiltration are referred to as precipitation losses. Interception and depression storage are intended to represent the surface storage of water by trees or grass, in local depressions in the ground surface, in cracks and crevices in parking lots or roofs, or in a surface area where water is not free to move as overland flow. Infiltration represents the movement of water to areas beneath the land surface.

Two important factors should be noted about the precipitation loss computations to be used for the SCS Unit Hydrograph methods. First, precipitation which does not contribute to the runoff process is considered to be lost from the system. Second, the equations used to compute the losses do not provide for soil moisture or surface storage recovery.

The precipitation loss component of the SCS Unit Hydrograph method is considered to be sub-basin average (uniformly distributed over an entire sub-basin). In some instances, there are negligible precipitation losses for a portion of a sub-basin. This would be true for an area containing a lake, reservoir or impervious area. In this case, precipitation losses will not be computed for a specified percentage of the area labeled as impervious.

There are several methods that can be used to calculate the precipitation loss. These methods include the Initial and Uniform Loss Rate, Exponential Loss Rate, Holtan Loss Rate, Horton Loss Rate, Green-Ampt and SCS Curve Number method to name a few. The SCS Curve Number method is recommended for the Washoe County area because there is a lack of data for use in other methods and the local consultants are familiar with using this method. In addition, modeling of sample areas within Washoe County has shown that this method will result in reasonable and justifiable runoff rates. The dynamic nature of flood hydrology may show that a different method of computing rainfall loss (i.e. Green-Ampt for example) may be more accurate than the CN method shown herein. However, a change in the loss methodology should only be made upon substantial showing that said method can be supported by available data. In the SCS Curve Number method, an average precipitation loss is determined for a computation interval and subtracted from the rainfall hyetograph. The resulting precipitation excess is used to compute an outflow hydrograph for a sub-basin.

703.2 SCS CURVE NUMBER METHOD

The SCS has instituted a soil classification system for use in Soil Survey maps across the country. Based on experimentation and experience, the agency has been able to relate the drainage characteristics of soil groups to a curve number, CN (SCS, 1985). The SCS provides information on relating soil group type to the curve number as a function of soil cover, land use type and antecedent moisture conditions.

Precipitation loss is calculated based on supplied values of CN and the initial surface moisture storage capacity (IA). CN and IA are related to a total runoff depth for a storm by the following relationships:

$$Q = (P-IA)^2 / ((P-IA) + S) \tag{705}$$

$$S = (1000/CN) - 10 \tag{706}$$

- where Q = Accumulated excess (inches)
- P = Accumulated rainfall depth (inches)
- IA = Initial surface moisture storage capacity (inches)
- S = Currently available soil moisture storage deficit (inches)

For the Washoe County area, IA is calculated by using the following equation:

$$IA = 0.2S \tag{707}$$

This relation is based on empirical evidence established by the Soil Conservation Service and is the default value in the HEC-1 or HEC-HMS program (HEC, 1990).

Since the SCS method gives total excess for a storm (the difference between rainfall and precipitation loss), the incremental excess for a time period is computed as the difference between the accumulated excess at the end of the current period and the accumulated excess at the end of the previous period.

703.2.1 CN DETERMINATION

The SCS Curve Number Method uses a soil cover complex number for computing excess precipitation. The curve number CN is related to hydrologic soil group (A, B, C, or D), land use, treatment class (cover), and antecedent moisture condition. The soil group is determined from published soil maps for the area. These maps are usually published by the SCS. Land use and treatment class are usually determined during investigations in conjunction with aerial photographs. The procedure for determining land use and treatment class is found in Chapter 8 of National

Engineering Handbook, Section 4 (SCS, 1985). The antecedent moisture condition of the watershed is explained as follows:

The amount of rainfall in a period of 5 to 30 days preceding a particular storm is referred to as antecedent rainfall, and the resulting condition of the watershed in regard to potential runoff is referred to as an antecedent moisture condition. In general, the heavier the antecedent rainfall, the greater the direct runoff that occurs from a given storm. The effects of infiltration and evapotranspiration during the antecedent period are also important, as they may increase or lessen the effect of antecedent rainfall. Because of the difficulties of determining antecedent storm conditions from data normally available, the conditions are reduced to three cases, AMC-I, AMC-II and AMC-III.

For the Washoe County area, an AMC-II condition shall be used for determining storm runoff.

Having determined the soil group, land use and treatment class and the antecedent moisture condition, CN values can be determined from Table 702.

There will be areas to which the values in Table 702 do not apply. The percentage of impervious area for the various types of residential areas or the land use condition for the pervious portions may vary from the conditions assumed in Table 702. A curve for each pervious CN can be developed to determine the composite CN for any density of impervious area. Figure 702 has been developed assuming a CN of 98 for the impervious area. The curves in Figure 702 can help in estimating the increase in runoff as more land within a given area is covered with impervious material.

There are a number of methods available for computing the percentage of impervious area in a watershed. Some methods include using U.S. Geological Survey topographic maps, land use maps, aerial photographs, and field reconnaissance. Care must be exercised when using methods based on such parameters as population density, street density, and age of the development as a means of determining the percentage of impervious area. The available data on runoff from urban areas are not yet sufficient to validate widespread use of these methods. Therefore, the CN to be used in the Washoe County area shall be based on Table 702 or Figure 702 in this Manual. A CN computation example is included in Section 711.

704 RATIONAL FORMULA METHOD

For drainage basins that are not complex and have small drainage areas, the design storm runoff may be analyzed using the Rational Formula Method in accordance with Section 304.3. This method was introduced in 1889 and is still being used in many engineering offices in the United States. Even though this method has frequently come under academic criticism for its simplicity, no other practical drainage design method has evolved to such a level of general acceptance by practicing engineers. The Rational Formula Method, when properly understood and applied, can produce satisfactory results for determining peak discharge.

704.1 METHODOLOGY

The Rational Formula Method is based on the formula:

$$Q = CIA \tag{708}$$

Q is defined as the maximum rate of runoff in cubic feet per second (actually, Q has units of acre inches per hour, which is approximately equal to the units of cubic feet per second). C is a runoff coefficient and represents the runoff-producing conditions of the subject land area (see Section 704.5).

I is the average intensity of rainfall in inches per hour for a duration equal to the time of concentration.
A is the contributing basin area in acres.

704.2 ASSUMPTIONS

The basic assumptions made when applying the Rational Formula Method are as follows:

1. The computed maximum rate of runoff to the design point is a function of the average rainfall rate during the time of concentration to that point.
2. The maximum rate of rainfall occurs during the time of concentration, and the design rainfall depth during the time of concentration is converted to the average rainfall intensity for the time of concentration.
3. The maximum runoff rate occurs when the entire area is contributing flow. However, this assumption has been modified from time to time when local rainfall/runoff data was used to improve calculated results.

704.3 LIMITATIONS ON METHODOLOGY

The Rational Formula Method adequately approximates the peak rate of runoff from a rainstorm in a given basin. The critics of the method usually are unsatisfied with the fact that the answers are only approximations. A shortcoming of the Rational Formula Method is that only one point on the runoff hydrograph is computed (the peak runoff rate).

Another disadvantage of the Rational Formula Method is that with typical design procedures one normally assumes that all of the design flow is collected at the design point and that there is no "carry over water" running overland to the next design point. However, this is not the fault of the Rational Formula Method, but of the design procedure. The problem becomes one of routing the surface and subsurface hydrographs which have been separated by the storm sewer system. In general, this sophistication is not warranted and a conservative assumption is made wherein the entire routing occurs through the storm sewer system when this system is present.

704.4 RAINFALL INTENSITY

The rainfall intensity, I, is the average rainfall rate in inches per hour for the period of maximum rainfall of a given frequency having a duration equal to the time of concentration. After the design storm frequency has been selected, a graph should be prepared showing rainfall intensity versus time. Information on local rainfall data is presented in Section 600 of this Manual.

704.5 RUNOFF COEFFICIENT

The runoff coefficient, C, represents the integrated effects of infiltration, evaporation, retention, flow routing, and interception, all which affect the time distribution and peak rate of runoff. Determination of the coefficient requires judgment and understanding on the part of the engineer. Table 701 presents the recommended values of C for the various recurrence frequency storms. The values are presented for different surface characteristics as well as for different aggregate land uses. Variations to these values are subject to the approval of the Jurisdictional Entity.

A composite runoff coefficient is computed on the basis of the percentage of different types of surfaces in the drainage area. For homogeneous developed areas, this procedure is often applied to a typical "sample" area as a guide to selection of reasonable values of the coefficient for an entire area. Suggested coefficients with respect to surface type are also given in Table 701 under the column

labeled "Percent Impervious". Where land use features are mixed, a composite C analysis will result in more accurate results. The runoff coefficients in Table 701 also vary with recurrence frequency.

704.6 APPLICATION OF THE RATIONAL FORMULA METHOD

The first step in applying the Rational Formula Method is to obtain a topographic map and define the boundaries of all the relevant drainage basins. Basins to be defined include all basins tributary to the area of study and sub-basins within the study area. A field check and possibly field surveys should be made for each basin. At this stage of planning, the possibility for the diversion of transbasin waters should be identified.

The major storm drainage basin does not always coincide with the minor storm drainage basin. This is often the case in urban areas where a low flow will stay next to a curb and follow the lowest grade, but when a large flow occurs the water will be deep enough so that part of the water will overflow street crowns and flow into a new sub-basin. An example of how to apply the Rational Formula Method is presented in Section 711.

704.7 MAJOR STORM ANALYSIS

When analyzing the major runoff occurring within an area that has a storm sewer system sized for the minor storm, care must be used when applying the Rational Formula Method. Normal application of the Rational Method assumes that all of the runoff is collected by the storm sewer. For the minor storm design, the time of concentration is dependent upon the flow time in the sewer. However, during the major storm runoff, the sewers will probably be at capacity and would not carry the additional water flowing to the inlets. This additional water then flows overland past the inlets, generally at a lower velocity than the flow in the storm sewers.

If a separate time of concentration analysis is made for the pipe flow and surface flow, a time lag between the surface flow peak and the pipe flow peak will occur. This lag, in effect, will allow the pipe to carry a larger portion of the major storm runoff than would be predicted using the minor storm time of concentration. The basis for this increased benefit is that the excess water from one inlet will flow to the next inlet downhill, using the overland route. If that inlet is also at capacity, the water will often continue on until capacity is available in the storm sewer. The analysis of this aspect of the interaction between the storm sewer system and the major storm runoff is complex. The simplified approach of using the minor storm time of concentration for all frequency analysis is acceptable for use in Washoe County.

705 SCS UNIT HYDROGRAPH METHOD

The SCS Unit Hydrograph method was developed for the SCS by Mr. Victor Mockus. The SCS Unit Hydrograph was derived from a large number of natural unit hydrographs from watersheds varying widely in size and geographic location. The SCS Unit Hydrograph has been in use for many years and has produced satisfactory results for many applications. This method may be used for drainage areas within the Washoe County area in accordance with Section 304.3.

705.1 METHODOLOGY

The SCS Unit Hydrograph method uses the unit hydrograph theory as a basis for runoff computations. The unit hydrograph theory computes rainfall excess hydrographs for a unit amount of rainfall excess applied uniformly over a sub-basin for a given unit of time (or unit duration). The rainfall excess hydrographs are then transformed to a sub-basin hydrograph by superimposing each excess hydrograph lagged by the unit duration.

The shape of the SCS Unit Hydrograph is based on studies of various natural unit hydrographs. The basic governing parameters of this curvilinear hydrograph are as follows:

1. The time-to-peak, T_p , of the unit hydrograph approximately equals 0.2 times the time-of-base, T_b .
2. The point of inflection of the falling leg of the unit hydrograph approximately equals 1.7 times T_p .

For ease of calculation, an equivalent triangular unit hydrograph was derived from the natural curvilinear unit hydrograph. From the triangular unit hydrograph, equations for the peak discharge, Q_p , time-to-peak, T_p , and the time of concentration, t_c were developed based on a single lag factor (TLAG). The discharge hydrograph is then determined for the SCS Unit Hydrograph method based on the storm excess precipitation applied to the unit hydrograph whose parameters are determined by TLAG. TLAG is defined and discussed in Section 705.3.

705.2 ASSUMPTIONS

The basic assumptions made when applying the SCS Unit Hydrograph method (and all other unit hydrograph methods) are as follows:

1. The effects of all physical characteristics of a given drainage basin are reflected in the shape of the storm runoff hydrograph for that basin.
2. At a given point on a stream, discharge ordinates of different unit graphs of the same unit time of rainfall excess are mutually proportional to respective volumes.
3. A hydrograph of storm discharge that would result from a series of bursts of excess rain or from continuous excess rain of variable intensity may be constructed from a series of overlapping unit graphs each resulting from a single increment of excess rain of unit duration.

705.3 LAG TIME

Input data for the Soil Conservation Service dimensionless unit hydrograph method (SCS, 1985) consists of a single parameter, TLAG, which is equal to the lag (in hours) between the center of mass of rainfall excess and the peak of the unit hydrograph. For small drainage basins (less than one square mile) and basin slopes less than ten percent the lag time may be related to the time of concentration, t_c , by the following empirical relationship:

$$TLAG = 0.6 t_c \tag{709}$$

The t_c is computed as presented in Section 702.

For larger drainage basins (greater than one square mile) and basins with a basin slope equal to or greater than ten percent, the lag time (and t_c) is generally governed mostly by the concentrated flow travel time, not the initial overland flow time. In addition, as the basin gets increasingly larger, the average flow velocity (and associated travel time) becomes more difficult to estimate. Therefore, for these basins, the following lag equation is recommended for use in computing TLAG:

$$TLAG = 22.1 K_n (L L_c/S)^{0.5} \tag{710}$$

where K_n = Roughness factor for the basin channels
 L = Length of longest watercourse (miles)

L_c = Length along longest watercourse measured upstream to a point opposite the centroid of the basin (miles)

S = Representative (average) slope of the longest watercourse (feet per mile)

This lag equation is based on the United States Bureau of Reclamation (USBR)'s analysis of the above parameters for several drainage basins in the Southwest desert, Great Basin, and Colorado Plateau area (USBR, 1989). Since the SCS and the USBR define lag differently, this equation was developed by modifying the USBR's S-graph lag equation to correspond to the SCS's definition of the dimensionless unit hydrograph lag equation.

In order to obtain comparable results between the t_c calculation and the TLAG calculation, it is recommended that either method be used as a check of the other method for drainage areas around one square mile in size.

705.3.1 ROUGHNESS FACTOR

The selection of a proper roughness factor for use in the lag time calculation is highly subjective. Therefore, in order to obtain more consistent lag time and runoff analysis results, the roughness factor, K_n , shall be determined using the factors presented in Table 703. These factors are based on roughness factor analysis performed in the Washoe County and Carson City areas, analysis performed for the Sacramento, California area, and by USBR (1989) as compared to the typical watershed channels found in the Washoe County area. The reader is referred to these documents for further discussion on selection of a proper roughness factor.

For partially developed basins, the roughness factor should be interpolated in relationship to the percent of each land use in the basin.

705.4 UNIT STORM DURATION

The minimum unit duration, Δt , is dependent on the time of concentration of a given basin. If the basin is large (i.e., > one square mile), a larger unit duration may be used. If the basin is small (i.e., < one square mile) a smaller unit duration should be used. The unit duration, Δt , should be $\leq .25 T_p$, where T_p is the time-to-peak of the unit hydrograph. For the Washoe County area the typical unit storm duration should be 5 minutes unless conditions warrant otherwise.

705.5 SUB-BASIN SIZING

The determination of the peak rate of runoff at a given design point is affected by the discretization of sub-basins in the subject basin. Typically, the more discrete the analysis of a given basin (more sub-basins), the larger the peak flow rate as compared to analysis of the basin with no sub-basins. Therefore, in order to obtain more consistent results between different designers as well as between different runoff models (i.e. Rational Formula Method vs. SCS method), the following guidelines are recommended for basin discretization:

1. For drainage basins up to 100 acres in size, the maximum sub-basin size should be approximately 20 acres.
2. For drainage basins over 100 acres in size, increasingly larger sub-basins may be used as long as the land use and surface characteristics within each sub-basin are homogeneous. In addition, the sub-basin sizing should be consistent with the level of detail needed to determine peak flow rates at various design points within a given basin.

706 CHANNEL ROUTING OF HYDROGRAPHS

Whenever a large or a non-homogeneous basin is being investigated, the basin should be divided into smaller and more homogeneous sub-basins. The storm hydrograph for each sub-basin can then be calculated using the procedures described in Sections 704 or 705. The user then must route and combine the individual sub-basin hydrographs to develop a storm hydrograph for the entire watershed. There are several methods available for use in channel routing which include:

- a. Muskingum
- b. Convex
- c. Direct Translation
- d. Storage-Discharge (Modified Puls)
- e. Kinematic Wave
- f. Diffusion Wave
- g. Dynamic Wave
- h. Muskingum-Cunge

The two most commonly used routing techniques are the Muskingum-Cunge (an approximate diffusion router) and the Kinematic Wave (a finite-difference technique). Of these, the Muskingum-Cunge is the preferable method for use in Washoe County. The Muskingum-Cunge method provides accurate results over a wide range of flow conditions, where as the Kinematic Wave method should only be used in relatively short reaches such as those encountered in an urban environment. Numerical errors introduced when solving the Kinematic Wave technique may cause a greater attenuation of the peak flow than actually occurs. The Kinematic Wave technique can only be used for specific types of channel shapes (i.e., trapezoidal, rectangular, etc.), but the Muskingum-Cunge technique can be used for channels with standard prismatic shapes or channels with irregular cross section shapes. Since the HEC-1 or HEC-HMS programs compute hydrograph lagging based on internally selected computation interval, the user should always check that the peak generated from the internally selected computation interval are comparable to the result peaks shown in the output at the user determined intervals. In some instances, an error message will occur with the Muskingum-Cunge method, which terminates the program computations. In this instance the Muskingum method should be used.

The reader is referred to the HEC-1 or HEC-HMS User's Manual for details on the development of Muskingum-Cunge and Kinematic Wave techniques and details on the parameters and procedures needed for their use in HEC-1 or HEC-HMS program.

707 RESERVOIR ROUTING OF HYDROGRAPHS

Storage as found in an enlargement of a river or drainage channel and storage in reservoirs may modify the shape of the flood hydrograph. If the reservoir does not have gates, the discharge (D) takes place over an uncontrolled weir or through an uncontrolled orifice in such a way that D is a function of the reservoir level.

Storm runoff detention is required for some new development (Section 303.7) and therefore detention reservoirs will be required (see Section 1300). In some instances, the sizing of the detention storage will be based upon hydrograph storage routing techniques rather than direct calculation of volume and discharge requirements. The methodology for manual computation of reservoir routing is presented in

this section. This method is computerized and is part of the HEC-1 or HEC-HMS program. The input requirements are explained in the HEC-1 or HEC-HMS User's Manual.

707.1 MODIFIED PULS METHOD

The procedure for the original Puls Method was developed in 1928 by L.G. Puls of the U.S. Army Corps of Engineers. The method was modified in 1949 by the Bureau of Reclamation simplifying the computational and graphic requirements. The method is also referred to as the Storage-Indication or Goodrich Reservoir Routing Method. The differences, if any, are mainly in the form of the equation and means of initializing the routing. The procedures presented herein were obtained from Hydrology for Engineers (Linsley, 1975).

The principle of mass continuity for a channel reach can be expressed by the equation:

$$(I-D)t = \Delta S \tag{720}$$

where I is the inflow rate, D is the discharge rate, t is the time interval, and ΔS is the change in storage. If the average rate of flow during a given time period is equal to the average of the flows at the beginning and end of the period, the equation can be expressed as follows:

$$(I_1 + I_2) t/2 - (D_1 + D_2) t/2 = S_2 - S_1 \tag{721}$$

where the subscripts 1 and 2 refer to the beginning and end of time period t. Rearranging the equation gives the following form used for the Modified Puls method:

$$I_1 + I_2 + (2S_1/t - D_1) = (2S_2/t + D_2) \tag{722}$$

Reservoir routing using the Modified Puls method may be analyzed using the HEC-1 or HEC-HMS computer program. The user is referred to the HEC-1 or HEC-HMS documentation for the required input parameters. Other computer programs that use the Modified Puls method may be allowed by the Jurisdictional Entity.

708 STATISTICAL ANALYSIS

For basins larger than 10 square miles, the preferred method to compute flood flows is generally to use actual records of discharges which have been recorded by gaged streams. The reliability of the statistical or regional approach is generally better than the Rational Method, Rainfall-Runoff models, or other deterministic model, provided the period of record is sufficiently long (i.e., 20 years or greater).

Before proceeding with a statistical analysis, the analyst shall contact the Jurisdictional Entity and the USGS to obtain (when available) applicable data, information, other relevant studies, and criteria for evaluation.

In urban hydrology, the preferred statistical approach is limited by: (1) the almost total lack of adequate runoff records in urban areas, (2) the effects of rapid urbanization, and (3) study areas having satisfactory gaging periods usually have records which represent the undeveloped basin condition. Once urbanization occurs, the records representing (non-urban) natural conditions no longer apply to urban conditions. Thus, use of the deterministic methods allowed in the Washoe County area will generally be required for urban or urbanizing areas.

The statistical analysis has the greatest applicability to natural streams where the basins will remain in a natural state. Such streams include those with large basins where the urbanization effect on runoff

will be negligible and on small streams where the basin primarily consists of undevelopable land or land comprising green belt areas.

In the statistical approach to determining the size of flood peaks, the logic involved is that nature over a period of years has defined a flood magnitude-frequency relationship that can be derived by study of actual occurrences. A period of record of a particular basin where the floods have been measured and recorded is considered to be a representative period. Floods that occurred during the period can be assumed to occur in a similar future period, that is, the period may be expected to repeat itself.

The purpose of statistical analysis is to use the recorded runoff events for a given period of record as a means of extrapolating to a longer period of time. For a 25-year period, the largest record flood is generally considered to have a recurrence interval of about 25 years. At the end of this 25 year period, because the period can be assumed to repeat itself, one could expect the largest flood of record to be equaled or exceeded at least one or more times during the next 25 years. For any given year the probability of a flood of any given frequency happening in that year is the same as the probability of it happening in any other year. Thus the 100-year flood has a 1 percent chance of being equaled or exceeded in any given year.

The statistical procedure acceptable for use in the Washoe County area is the one described by the Interagency Advisory Committee (IAC) on Water Data that utilizes the Log Pearson Type III distribution (IAC, 1982). Any independent statistical analysis of records in the Washoe County area should follow the procedure outlined by the IAC.

709 VOLUME OF RUNOFF AND STORAGE VOLUMES

709.1 GENERAL

Until recently, standard of care for hydrologic and hydraulic analysis with respect to development focused largely on peak runoff from a given site, and required the engineer to mitigate increases in peak flows to predevelopment flow rates. Currently, consideration of either flood plain storage or the downstream impact from increases in the total volume of runoff is difficult and time-intensive and is normally considered impractical. There are, however, a few critical areas within the Truckee Meadows region for which consideration of storage volume and runoff volume is considered to be warranted. Though proponents of the no-adverse-impact (NAI) approach to flood plain management would argue that consideration of storage volumes and runoff volumes should be intrinsic to any hydrologic calculation, the Jurisdictional Entities have currently only required such consideration for a few limited areas, which are as follows:

709.2 NORTH VALLEYS (CITY OF RENO AND WASHOE COUNTY ONLY)

Runoff from within the Silver Lake and Swan Lake (aka Lemmon Lake) hydrographic basins will ultimately discharge to the Silver Lake Playa or the Swan Lake Playa, respectively. A detailed hydrologic analysis and resultant water surface elevation (in the playa) produced by the 1% chance precipitation event was the subject of a detailed study performed by Quad Knopf (Refer to: North Valleys Flood Control Hydrologic Analysis and Mitigation Options, Volumes I and II; Quad Knopf, March 30, 2007, prepared for the Washoe County Regional Water Planning Commission and the City of Reno). This study shows that any increases in runoff volume due to development (or loss of flood plain storage due to development) will impact the FEMA regulated water surface elevation in the playas. Future development shall account for the increased volume of runoff generated (within the basin), as well as for flood plain storage volumes within the 100-year flood plain. Development within these basins shall require a hydrology report identifying required mitigation, if any, to maintain the water surface elevations within the playas for the 1% chance event (no net increase allowed). Volumetric analysis is to be based on the 100-year, 10-day storm event, while routing of peak flows

shall be based on the 100-year, 24-hour storm event. See Reno Municipal Code 18.12.1703(g) and Washoe County Development Code Article 416 for restrictions on closed basins. Due to zoning overlays which regulate the proximity of structures and land uses adjacent to the White Lake Playa (Cold Springs Area), it is not anticipated that future development will exacerbate flooding. As such, limitations to volume of runoff are not in force for the White Lake Basin (a closed basin).

709.3 FLOOD PLAIN STORAGE WITHIN THE TRUCKEE RIVER WATERSHED

The Washoe County Comprehensive Regional Water Management Plan 2004-2025 defines the issues and delineates the boundaries with respect to flood plain storage within the Truckee River Watershed. Currently, Washoe County and the City of Reno require all proposed land use changes and proposed projects within the Critical Flood Pool (Zone 1) to be reviewed for their impact on hydrologically connected and downstream properties. See Reno Municipal Code 18.12.605 and Washoe County Development Code Article 416 for limitations on runoff (peak and volume) and loss of flood storage, and for mitigation options.

710 GREEN AND APMT METHOD (placeholder for future section)

711 EXAMPLE APPLICATIONS

711.1 EXAMPLE: RATIONAL FORMULA METHOD

Problem: Determine the 5-year flow at the design points within Rose Subdivision shown in Figure 703. The flow sequence is as follows: Design Point 1 flows to Design Point 2. Design Point 2 flows to Design Point 3. Design Point 5 flows to Design Point 6. Design Points 3 and 6 flow to Design Point 4. Design Point 4 flows into the proposed detention basin represented by Design Point 7 and Design Point 7 finally flows to Design Point 8 located in Doe Creek.

Solution:

Step 1: Estimate the flow runoff coefficients for each sub-basin in Rose Subdivision. Rose Subdivision is a single family residential area with an average lot size of 1/3 acre. The flow runoff coefficient, R, is assumed to be equal to the 5-year runoff coefficient, C₅, which are provided in Table 701.

$$R_A = R_B = R_C = R_D = R_E = R_F = R_G = C_5 = 0.45$$

Step 2: Calculate the initial overland flow time, t_i, for each sub-basin in Rose Subdivision. Assume the lot depth in each sub-basin is 150 feet and slopes at a grade of 1.5% to the street.

$$t_{i_A} = t_{i_B} = t_{i_C} = t_{i_D} = t_{i_E} = t_{i_D} = \frac{1.8(1.1 - R)L^{1/2}}{S^{1/3}} = \frac{1.8(1.1 - 0.45)(150)^{1/2}}{(1.5)^{1/3}} = 12.5 \text{ Minutes}$$

Step 3: Compute the travel time of the runoff in the street gutter to the designated design point using Figure 701. Only the calculation for the travel time to Design Point 1 is shown in the example. The results of the remaining travel time calculations are shown in Table 704.

Assuming the runoff combines and flows down the street at a 2.5% grade, Figure 701 estimates the runoff velocity in the street to be:

$$V_A = 3.4 \text{ feet per second (fps)}$$

The gutter flow length in sub-basin A is:

$$L_A = 900 \text{ feet}$$

and the travel time will be:

$$t_{t_A} = \frac{L}{60V} = \frac{900}{60 * 3.4} = 4.4 \text{ Minutes}$$

- Step 4: Calculate the time of concentration using Equations 701 and 704 at Design Point 1. Select the smaller time delivered by the two equations as the final time of concentration at each design point.

$$t_{c_1} = t_i + t_t = 12.5 + 4.4 = 16.9 \text{ Minutes}$$

$$t_{c_1} = \frac{L}{180} + 10 = \frac{1050}{180} + 10 = 15.8 \text{ Minutes}$$

Since Equation 704 gives the smaller value, the time of concentration at Design Point 1 is:

$$t_{C_1} = 15.8 \text{ Minutes}$$

- Step 5: Estimate the time of concentration at downstream design points. When multiple sub-basins drain to a common design point, continue the time of concentration calculations in the downstream direction. The flow calculated at each design point is used to estimate the flow velocity in the downstream pipe, gutter, swale, or channel.

This flow velocity is then used to calculate the time of travel to the next downstream design point. Table 704 shows the use of Standard Form 2 and presents the results of the remaining calculations to determine the time of concentration at each design point.

- Step 6: Determine the 5-year runoff coefficient (C_5) at each design point from Table 701.

$$C_{5_1} = C_{5_2} = C_{5_3} = C_{5_4} = C_{5_5} = C_{5_6} = C_{5_7} = C_{5_8} = 0.45$$

(Note: A composite runoff coefficient may need to be calculated if the drainage area flowing to the design point contains more than one land use or surface characteristic).

- Step 7: Determine the 5-year rainfall intensity (I_5) at each design point using the time of concentration calculations in Step 4 (and shown in Table 704) and the appropriate rainfall intensity duration frequency curve per Section 600. For this example assume these values:

$$I_{5_1} = 1.23 \text{ Inches/hour}$$

$$I_{5_2} = 1.22 \text{ Inches/hour}$$

$$I_{5_3} = 1.18 \text{ Inches/hour}$$

$$I_{5_4} = 1.16 \text{ Inches/hour}$$

$$I_{5_5} = 1.23 \text{ Inches/hour}$$

$$I_{5_6} = 1.18 \text{ Inches/hour}$$

$$I_{5_7} = 1.14 \text{ Inches/hour}$$

Step 8: Calculate the 5-year peak flow (Q_5) at each design point using Equation 708.

$$Q_{5_1} = C_{5_1} * I_{5_1} * A_1 = 0.45 * 1.23 * 4.13 = 2.3 \text{ cfs}$$

$$Q_{5_2} = 0.45 * 1.22 * 5.94 = 3.3 \text{ cfs}$$

$$Q_{5_3} = 0.45 * 1.18 * 8.26 = 4.4 \text{ cfs}$$

$$Q_{5_4} = 0.45 * 1.16 * 14.72 = 7.7 \text{ cfs}$$

$$Q_{5_5} = 0.45 * 1.23 * 3.36 = 1.9 \text{ cfs}$$

$$Q_{5_6} = 0.45 * 1.18 * 4.65 = 2.5 \text{ cfs}$$

$$Q_{5_7} = 0.45 * 1.14 * 15.5 = 8.0 \text{ cfs}$$

Step 9: The 100-year peak flow at each design point was not performed in this example problem but may be obtained by repeating Steps 6 through 8 using 100-year runoff coefficients and rainfall intensities.

APPLICATION: The results from the Rational Formula Method are used to design the drainage system in an urban environment. The results from this example problem will be used in subsequent example problems.

711.2 EXAMPLE: SCS UNIT HYDROGRAPH METHOD

Problem: Determine the 100-year, 24-hour runoff hydrograph on Doe Creek immediately upstream of John Boulevard and Rose Subdivision.

Solution:

Step 1: Measure the drainage area of the basin. For this example, assume the drainage area is:

$$DA = 3.34 \text{ square miles} = 2140 \text{ acres}$$

Step 2: Estimate the average curve number of the basin. Assume the basin can be divided into the following land uses.

Land Use	Soil Type	CN	Area (Acres)
Forest	B	54	200
Forest	C	66	1100
Shrub/Brush	B	56	840

$$CN_{Ave} = (54*200+66*1100+56*840)/2140=61.0$$

Step 3: Measure the length of the longest water course (L). For this example assume:

$L = 22100 \text{ feet} = 4.19 \text{ miles}$

Step 4: Measure the length along Doe Creek from the John Boulevard Bridge to the point opposite the centroid of the basin (L_c). For this example assume:

$L_c = 2.05 \text{ miles}$

Step 5: Calculate the average slope of Doe Creek. For this example assume:

Elevation of furthest upstream point = 7,276 feet
 Elevation at John Boulevard = 4,920 feet

$$\text{Slope} = \frac{7276 - 4920}{4.19} = 563 \text{ feet/mile}$$

Step 6: Estimate the average roughness factor, K_n for Doe Creek using Table 703.

Land Use	K_n	Area
Forest	.15	1,300
Shrub/Brush	.1	840

$$K_n = (0.15 * 1300 + 0.1 * 840) / 2,140 = 0.130$$

Step 7: Calculate the lag time (TLAG) for the SCS dimensionless unit hydrograph using Equation 710.

$$\text{TLAG} = 22.1 * K_n * (L * L_c / S)^{0.5}^{0.33}$$

$$\text{TLAG} = 22.1 * 0.13 * (4.19 * 2.05 / 563)^{0.5}^{0.33} = 2.05 \text{ hours}$$

Step 8: Input the necessary information into the HEC-1 or HEC-HMS program and run HEC-1 or HEC-HMS to obtain the 100-year, 24-hour storm hydrograph at John Boulevard Bridge. The HEC-1 or HEC-HMS program will require KK, BA, LS, PH, and UD cards. The rainfall distribution information was obtained from Section 604.2. The results from HEC-1 model are provided in Figure 704.

References

IAC, 1982 - *Guidelines for Determining Flood Flow Frequency - Bulletin No. 17B, Interagency Advisory Committee on Water Data*, (US Department of the Interior, Geological Survey, March, 1982).

Linsley, 1975 - Linsley, Kohler, and Paulhus, *Hydrology for Engineers, 2nd Edition* (McGraw-Hill Company, New York, 1975).

SCS, 1986 - *TR-55 Urban Hydrology for Small Watersheds* (US Department of Agriculture, Soil Conservation Service, Washington, DC, June 1986).

**RATIONAL FORMULA METHOD
RUNOFF COEFFICIENTS**

Land Use or Surface Characteristics	Aver. % Impervious Area	Runoff Coefficients	
		5-Year (C ₅)	100-Year (C ₁₀₀)
<u>Business/Commercial:</u>			
Downtown Areas	85	.82	.85
Neighborhood Areas	70	.65	.80
<u>Residential:</u>			
(Average Lot Size)			
1/8 Acre or Less (Multi-Unit)	65	.60	.78
1/4 Acre	38	.50	.65
1/8 Acre	30	.45	.60
1/2 Acre	25	.40	.55
1 Acre	20	.35	.50
<u>Industrial:</u>			
	72	.68	.82
<u>Open Space:</u>			
(Lawns, Parks, Golf Courses)	5	.05	.30
<u>Undeveloped Areas:</u>			
Range	0	.20	.50
Forest	0	.05	.30
<u>Streets/Roads:</u>			
Paved	100	.88	.93
Gravel	20	.25	.50
<u>Drives/Walks:</u>			
	95	.87	.90
<u>Roof:</u>			
	90	.85	.87

Notes:

1. Composite runoff coefficients shown for Residential, Industrial, and Business/Commercial Areas assume irrigated grass landscaping for all pervious areas. For development with landscaping other than irrigated grass, the designer must develop project specific composite runoff coefficients from the surface characteristics presented in this table.

VERSION: April 30, 2009	REFERENCE:	TABLE
	USDCM, DROCOG, 1969 (with modifications)	701

RUNOFF CURVE NUMBERS FOR URBAN AREAS¹

Runoff Curve Numbers

Cover Type and Hydrologic Condition	Aver. % Impervious Area ²	Soil Comp A	Soil Comp B	Soil Comp C	Soil Comp D
<i>Fully developed urban area (vegetation established)</i>					
Open space (lawns, parks, golf courses, cemeteries, etc.) ³					
Poor condition (grass cover < 50%)		68	79	86	89
Fair condition (grass cover 50 to 75%)		49	69	79	84
Good condition (grass cover > 75%)		39	61	74	80
Impervious areas:					
Paved parking lots, roofs, driveways, etc. (excluding right-of-way)		98	98	98	98
Streets and roads:					
Paved; curbs and storm sewers (excluding right-of-way)		98	98	98	98
Paved; open ditches (including right-of-way)		83	89	92	93
Gravel (including right-of-way)		76	85	89	91
Dirt (including right-of-way)		72	82	87	89
Western desert urban areas:					
Natural desert landscaping (pervious areas only) ⁴		63	77	85	88
Artificial desert landscaping (impervious weed barrier, desert shrub with 1- to 2-inch sand or gravel mulch and basin borders)		96	96	96	96
Urban districts:					
Commercial and business	85	89	92	94	95
Industrial	72	81	88	91	93
Residential districts by average lot size:					
1/8 acre or less (town houses)	65	77	85	90	92
1/4 acre	38	61	75	83	87
1/3 acre	30	57	72	81	86
1/2 acre	25	54	70	80	85
1 acre	20	51	68	79	84
2 acres	12	46	65	77	82
<i>Developing urban areas</i>					
Newly graded areas (pervious only, no vegetation) ⁵		77	86	91	94
Idle lands (CNs are determined using cover types similar to those Table 702 - 3 of 4)					

¹Average runoff condition, and $I_a = 0.2S$

²The average percent impervious area shown was used to develop the composite CNs. Other assumptions are as follows: impervious areas are directly connected to the drainage system, impervious areas have a CN of 98, and pervious areas are considered equivalent to open space in good hydrologic condition. CNs for other combinations of conditions may be computed using figure 2-3 or 2-4 in TR-55 (SCS, 1986).

³CNs shown are equivalent to those of pasture. Composite CNs may be computed for other combinations of open space cover type.

⁴Composite CNs for natural desert landscaping should be computed using figure 2-3 or 2-4 in TR-55 (SCS, 1986) based on the impervious area percentage (CN = 98) and the pervious area CN. The pervious area CNs are assumed equivalent to desert shrub in poor hydrologic condition.

⁵Composite CNs to use for the design of temporary measures during grading and construction should be computed using figure 2-3 or 2-4 in TR-55 (SCS, 1986) based on the degree of development (impervious area percentage) and the CNs for the newly graded pervious areas.

VERSION: April 30, 2009

REFERENCE:

210-VI-TR-55, Second Edition, June 1986

TABLE

702

1 of 4

WTC ENGINEERING, INC.

RUNOFF CURVE NUMBERS FOR CULTIVATED AGRICULTURAL LANDS¹

Runoff Curve Numbers

Cover type	Treatment ²	Hydrologic condition ³	Soil Comp A	Soil Comp B	Soil Comp C	Soil Comp D
Fallow	Bare soil Crop residue cover (CR)	-	77	86	91	94
		Poor	76	85	90	93
		Good	74	83	88	90
Row crops	Straight row (SR)	Poor	72	81	88	91
		Good	67	78	85	89
	SR + CR	Poor	71	80	87	90
		Good	64	75	82	85
	Contoured (C)	Poor	70	79	84	88
		Good	65	75	82	86
	C + CR	Poor	69	78	83	87
		Good	64	74	81	85
	Contoured & terraced (C&T)	Poor	66	74	80	82
		Good	62	71	78	81
C&T + CR	Poor	65	73	79	81	
	Good	61	70	77	80	
Small grain	SR	Poor	65	76	84	88
		Good	63	75	83	87
	SR + CR	Poor	64	75	83	86
		Good	60	72	80	84
	C	Poor	63	74	82	85
		Good	61	73	81	84
	C + CR	Poor	62	73	81	84
		Good	60	72	80	83
	C&T	Poor	61	72	79	82
		Good	59	70	78	81
C&T + CR	Poor	60	71	78	81	
	Good	58	69	77	80	
Close-seeded or broadcast legumes or rotation meadow	SR	Poor	66	77	85	89
		Good	58	72	81	85
	C	Poor	64	75	83	85
		Good	55	69	78	83
	C&T	Poor	63	73	80	83
		Good	51	67	76	80

¹Average runoff condition, and $I_a = 0.2S$

²Crop residue cover applies only if residue is on at least 5% of the surface throughout the year.

³Hydrologic condition is based on combination of factors that affect infiltration and runoff, including: (a) density and canopy of vegetative areas, (b) amount of year-round cover, (c) amount of grass or close-seeded legumes in rotations, (d) percent of residue cover on the land surface (good $\geq 20\%$), and (e) degree of surface roughness.

Poor: Factors impair infiltration and tend to increase runoff.

Good: Factors encourage average and better than average infiltration and tend to decrease runoff.

RUNOFF CURVE NUMBERS FOR OTHER AGRICULTURAL LANDS¹

Runoff Curve Numbers

Cover Type	Hydrologic Condition	Soil Comp A	Soil Comp B	Soil Comp C	Soil Comp D
Pasture, grassland, or range – continuous forage for grazing ²	Poor	68	79	86	89
	Fair	49	69	79	84
	Good	39	61	74	80
Meadow – continuous grass, protected from grazing and generally mowed for hay	-	30	58	71	78
Brush – brush-weed-grass mixture with brush the major element ³	Poor	48	67	77	83
	Fair	35	56	70	77
	Good	30 ⁴	48	65	73
Woods – grass combination (orchard or tree farm) ⁵	Poor	57	73	82	86
	Fair	43	65	76	82
	Good	32	58	72	79
Woods ⁶	Poor	45	66	77	83
	Fair	36	60	73	79
	Good	30 ⁴	55	70	77
Farmsteads – buildings, lanes, driveways, and surrounding lots	-	59	74	82	86

¹Average runoff condition, and $I_a = 0.2S$

²*Poor*: < 50% ground cover or heavily grazed with no mulch
Fair: 50 to 75% ground cover and not heavily grazed
Good: > 75% ground cover and lightly or only occasionally grazed

³*Poor*: < 50% ground cover
Fair: 50 to 75% ground cover
Good: >75% ground cover

⁴Actual curve number is less than 30; use CN = 30 for runoff computations.

⁵CNs shown were computed for areas with 50% woods and 50% grass (pasture) cover. Other combinations of conditions may be computed from the CNs for woods and pasture.

⁶*Poor*: Forest litter, small trees, and brush are destroyed by heavy grazing or regular burning.
Fair: Woods are grazed but not burned, and some forest litter covers the soil.
Good: Woods are protected from grazing, and litter and brush adequately cover the soil.

VERSION: April 30, 2009

WTC ENGINEERING, INC.

REFERENCE:

210-VI-TR-55, Second Edition, June 1986

TABLE

702
3 of 4

RUNOFF CURVE NUMBERS FOR ARID AND SEMIARID RANGELANDS¹
Runoff Curve Numbers

Cover Description	Hydrologic Condition ²	Soil Comp A ³	Soil Comp B	Soil Comp C	Soil Comp D
Herbaceous – mixture of grass, weeds, and low-growing brush, with brush the minor element.	Poor		80	87	93
	Fair		71	81	89
	Good		62	74	85
Oak-aspen – mountain brush mixture of oak brush, aspen, mountain mahogany, bitter brush, maple, and other brush	Poor		66	74	79
	Fair		48	57	63
	Good		30	41	48
Pinyon-juniper – pinyon, juniper, or both; grass understory	Poor		75	85	89
	Fair		58	73	80
	Good		41	61	71
Sagebrush with grass understory	Poor		67	80	85
	Fair		51	63	70
	Good		35	47	55
Desert shrub – major plants include saltbrush, greasewood, creosotebush, blackbrush, bursage, palo verde, mesquite, and cactus	Poor	63	77	85	88
	Fair	55	72	81	86
	Good	49	68	79	84

¹Average runoff condition, and $I_a = 0.2S$. For range in humid regions, use Table 702 - 3 of 4.

²*Poor*: < 30% ground cover (litter, grass, and brush overstory)

Fair: 30 to 70% ground cover

Good: > 70% ground cover

³Curve numbers for group A have been developed only for desert shrub.

TRUCKEE MEADOWS REGIONAL DRAINAGE MANUAL

TRAVEL TIME VELOCITY

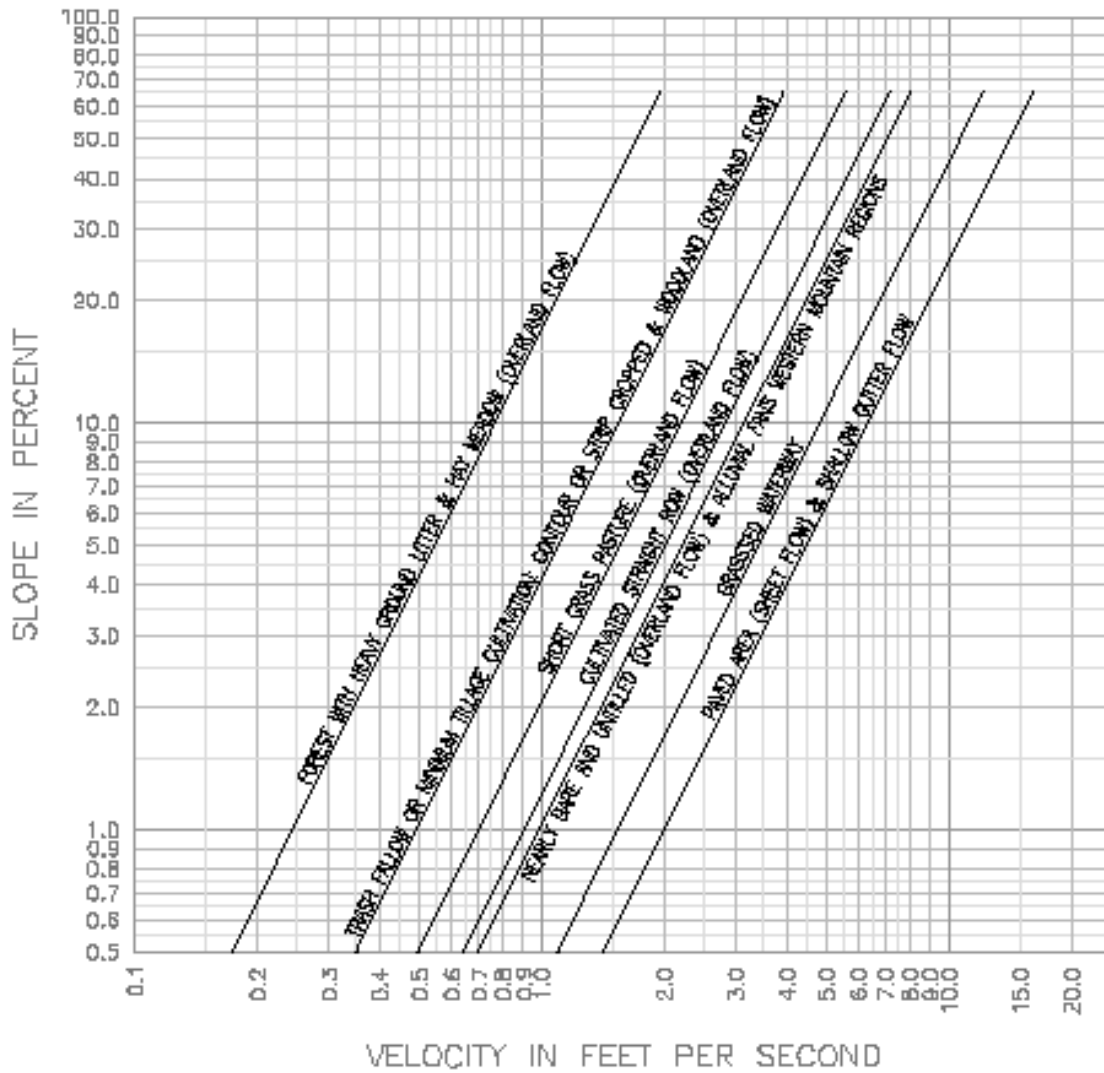

Version: April 30, 2009

PLACES—CSI

REFERENCE:

Soil Conservation Service, 1985 (Modified)

FIGURE

701

TRUCKEE MEADOWS REGIONAL DRAINAGE MANUAL

PERCENTAGE OF IMPERVIOUS AREA VS. COMPOSITE CNs
FOR GIVEN PERVIOUS AREA CNs

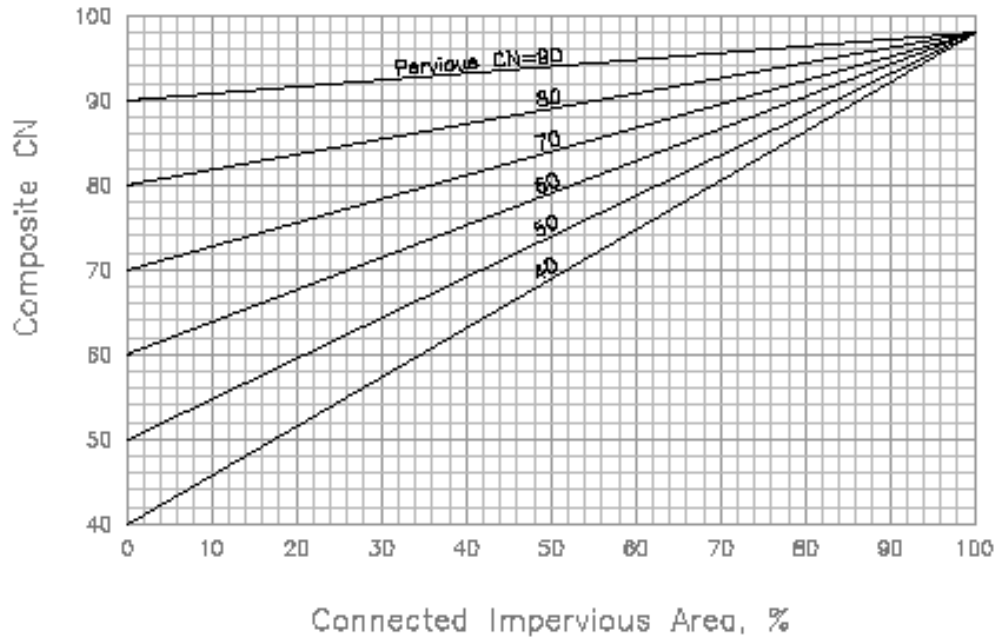

NOTE:

Refer to Table 701 for CN values for various land use conditions.

Version: April 30, 2009

PLACES—CSI

REFERENCE:

San Conservation Service, 1985 (modified)

FIGURE
702

TRUCKEE MEADOWS REGIONAL DRAINAGE MANUAL

EXAMPLE: PROPOSED ROSE SUBDIVISION

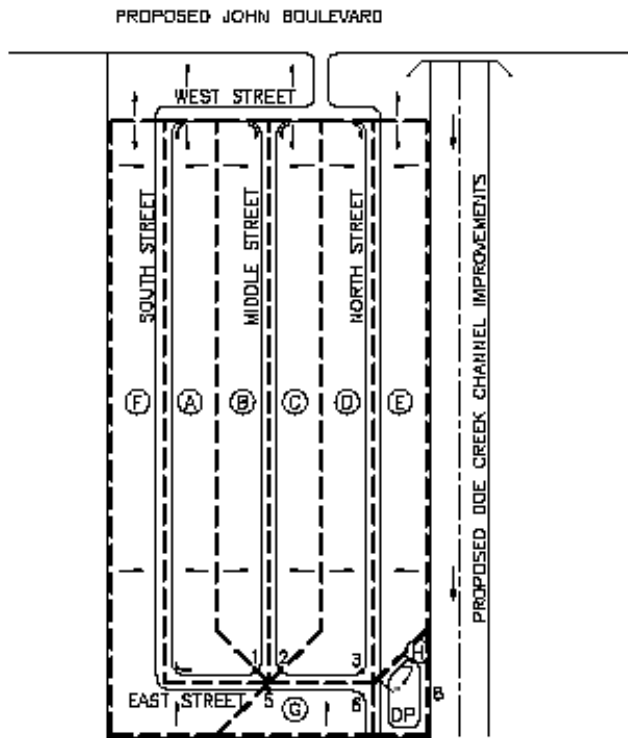
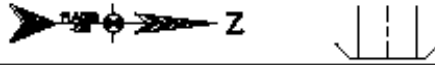

LEGEND

- | | | | |
|-----|-------------------------------|-----|-------------------------|
| Ⓒ | DRAINAGE BASIN IDENTIFICATION | 6 | DESIGN POINT |
| --- | BASIN BOUNDARY | --- | FLOW LINE |
| ↘ | FLOW INDICATR | —/— | PROPOSED BRIDGE |
| → | SLOPE INDICATOR | —/— | PROPERTY BOUNDARY |
| | | DP | PROPOSED DETENTION POND |

Version: April 30, 2009

REFERENCE:

FIGURE 703

PLACES—CSI

EXAMPLE: HEC-1 INPUT AND OUTPUT FOR BASIN A

PAGE 1

HEC-1 INPUT

1	LINE	ID.....	1.....	2.....	3.....	4.....	5.....	6.....	7.....	8.....	9.....	10.....
1		ID	WASHOE COUNTY DRAINAGE CRITERIA MANUAL EXAMPLE									
2		ID	DOE CREEK									
3		ID	24-HR. 100-YEAR EVENT									
4		ID	WRC ENGINEERING, INC.									
5		IT	5	0	300							
6		IO	2									
7		JR	PREC	.995								
8		KK	A	BASIN A HYDROGRAPH								
9		BA	3.34									
10		LS	0	61								
11		PH		.001	.48	.87	1.45	1.69	1.88	2.26	2.91	3.55
12		UD	2.05									
13		ZZ										

HEC-1 OUTPUT

**PEAK FLOW AND STAGE (END-OF-PERIOD) SUMMARY
FOR MULTIPLE PLAN-RATIO ECONOMIC COMPUTATION
FLOWS IN CUBIC FEET PER SECOND, AREA IN SQUARE MILES
TIME TO PEAK IN HOURS**

OPERATION	STATION	AREA	PLAN	RATIO 1
				1.00
HYDROGRAPH AT	A	3.34	1	FLOW
+				TIME
				191
				14.58

NORMAL END OF HEC-1

SECTION 800 - OPEN CHANNELS

TABLE OF CONTENTS

	<u>Page</u>
801 INTRODUCTION	803
802 OPEN CHANNEL HYDRAULICS	803
802.1 UNIFORM FLOW	803
802.2 UNIFORM CRITICAL FLOW ANALYSIS	804
802.3 GRADUALLY VARYING FLOW	805
802.4 RAPIDLY VARYING FLOW	805
802.5 TRANSITIONS	806
803 CHANNEL SELECTION	806
803.1 CHANNEL TYPES	806
803.2 CHANNEL SELECTION	807
803.3 MAXIMUM PERMISSIBLE VELOCITIES	809
804 NATURAL CHANNEL DESIGN	809
804.1 INTRODUCTION	809
804.2 NATURAL CHANNEL MORPHOLOGY AND RESPONSE	812
804.3 NATURAL CHANNEL DESIGN	821
804.4 NATURAL CHANNEL STABILIZATION	831
804.5 FLOOD PLAIN MANAGEMENT OF NATURAL CHANNELS	833
805 IMPROVED CHANNEL DESIGN	834
805.1 GENERAL REQUIREMENTS	834
805.2 PERMANENT UNLINED CHANNELS	835
805.3 NON-REINFORCED GRASS-LINED CHANNELS	835
805.4 WETLAND BOTTOM CHANNELS	838
805.5 RIPRAP-LINED CHANNELS	840
805.6 CONCRETE-LINED CHANNELS	848
805.7 OTHER CHANNEL LININGS	851
806 ADDITIONAL HYDRAULIC DESIGN STANDARDS	855
806.1 SUBCRITICAL FLOW DESIGN STANDARDS	856
806.2 SUPERCRITICAL FLOW DESIGN STANDARDS	858
807 CHANNEL APPURTENANCES	861
807.1 MAINTENANCE ACCESS ROAD	861
807.2 SAFETY REQUIREMENTS	861
807.3 CULVERT OUTLET PROTECTION	862
807.4 GRADE CONTROL STUCTURES	863
808 EXAMPLE APPLICATION	869
808.1 EXAMPLE: OPEN CHANNEL DESIGN FOR DOE CREEK	869
808.2 EXAMPLE: DETERMINE EQUILIBRIUM SLOPE BY THE THREE SLOPE METHOD ...	871
808.3 EXAMPLE: DETERMINE THE EQUILIBRIUM SLOPE BY POWER RELATIONS	872

LIST OF TABLES

801 GEOMETRIC ELEMENTS OF CHANNEL SECTIONS
802 TYPICAL ROUGHNESS COEFFICIENTS FOR OPEN CHANNELS
803 MAXIMUM PERMISSIBLE MEAN CHANNEL VELOCITIES
804 POTENTIAL EFFECTS OF MAJOR MAN-MADE DISTURBANCES
805 POWER EQUATIONS FOR TOTAL BED MATERIAL DISCHARGE IN SAND- AND FINE- GRAVEL-BED STREAMS
806 RANGE OF PARAMETERS FOR THE SIMONS-LI-FULLERTON METHOD
807 CHECKLIST OF DATA NEEDS FOR NATURAL CHANNEL ANALYSIS
808 SUMMARY OF APPLICATIONS OF STREAM STABILIZATION TECHNIQUES
809 RIPRAP GRADATION FOR STEEP SLOPES

LIST OF FIGURES

801 OPEN-CHANNEL FLOW CONDITIONS
802 CRITICAL DEPTH FOR TRAPEZOIDAL AND CIRCULAR SECTIONS
803 TYPICAL OPEN CHANNEL DESIGN SECTIONS (NATURAL CHANNEL)
804 ILLUSTRATION OF TERMINOLOGY FOR BEND-SCOUR CALCULATIONS
805 FORCES ACTING ON A CHANNEL BANK ASSUMING THERE IS A ZERO PORE WATER PRESSURE
806 STABILITY NUMBER (NS) AS A FUNCTION OF BANK ANGLE (θ) FOR A FAILURE SURFACE PASSING THROUGH THE BANK TOE
807 EXAMPLE OF BANK STABILITY CHART FOR ESTIMATING CRITICAL BANK HEIGHT (HC)
808 CRITICAL BANK-SLOPE CONFIGURATIONS FOR VARIOUS RANGES OF COHESIVE STRENGTHS UNDER SATURATED CONDITIONS
809 TYPICAL OPEN-CHANNEL DESIGN SECTIONS (IMPROVED CHANNELS)
810 ROUGHNESS COEFFICIENT FOR GRASS-LINED CHANNELS
811 TYPICAL CROSS-SECTION OF CONCRETE-LINED LOW-FLOW CHANNEL
812 TYPICAL CROSS-SECTION OF RIPRAP-LINED LOW-FLOW CHANNEL
813 TYPICAL CROSS-SECTION OF LOW-FLOW CHANNEL
814 MANNINGS ROUGHNESS COEFFICIENT FOR WETLAND BOTTOM
815 TYPICAL CROSS-SECTION FOR RIPRAP-LINED CHANNELS
816 TYPICAL CROSS-SECTION FOR GROUTED RIPRAP LINING
817 TYPICAL GROUTED RIPRAP SECTION
818A OPTIMUM RIPRAP SIDE SLOPE FOR A GIVEN SIZE RIPRAP
818B RIPRAP END PROTECTION
818C TOE PROTECTION ALTERNATIVES
818D TOE PROTECTION
818E LAUNCHING TOE MATERIAL
818F "DUTCH" TOE

- 819 STEEP SLOPE RIPRAP DESIGN, TRIANGULAR CHANNELS, 2:1 SIDESLOPES
- 820 STEEP SLOPE RIPRAP DESIGN, TRAPEZOIDAL CHANNELS, 2:1 SIDESLOPES, 6 FT BASE WIDTH
- 821 STEEP SLOPE RIPRAP DESIGN, TRAPEZOIDAL CHANNELS, 2:1 SIDESLOPES, 10 FT BASE WIDTH
- 822 STEEP SLOPE RIPRAP DESIGN, TRAPEZOIDAL CHANNELS, 2:1 SIDESLOPES, 14 FT BASE WIDTH
- 823 STEEP SLOPE RIPRAP DESIGN, TRAPEZOIDAL CHANNELS, 2:1 SIDESLOPES, 20 FT BASE WIDTH
- 824 SLOPE GABION MATTRESS LINING
- 825 CHANNEL TRANSITION TYPES
- 826 TYPICAL CHANNEL TRANSITION SECTIONS AND ENERGY LOSS COEFFICIENTS
- 827 TYPICAL CONTRACTING TRANSITION FOR SUPERCRITICAL FLOW
- 828 DESIGN CHART FOR CONTRACTING TRANSITION FOR SUPERCRITICAL FLOW
- 829 CONFIGURATION OF CULVERT OUTLET PROTECTION
- 830 PREFORMED SCOUR HOLE
- 831 SPACING OF GRADE CONTROL STRUCTURE
- 832A AS BUILT RIPRAP GRADE CONTROL STRUCTURE WITH SUFFICIENT LAUNCH STONE TO HANDLE ANTICIPATED SCOUR
- 832B LAUNCHING OF RIPRAP AT GRADE CONTROL STRUCTURE IN RESPONSE TO BED DEGRADATION AND LOCAL SCOUR
- 833A AS BUILT RIPRAP GRADE CONTROL STRUCTURE WITH IMPERVIOUS FILL CUTOFF WALL
- 833B LAUNCHING OF RIPRAP AT GRADE CONTROL STRUCTURE IN RESPONSE TO BED DEGRADATION AND LOCAL SCOUR
- 834A AS BUILT RIPRAP GRADE CONTROL STRUCTURE WITH SHEET PILE CUTOFF WALL
- 834B LAUNCHING OF RIPRAP AT GRADE CONTROL STRUCTURE IN RESPONSE TO BED DEGRADATION AND LOCAL SCOUR
- 835 SLOPING DROP GRADE CONTROL STRUCTURE WITH PRE-FORMED RIPRAP LINED SCOUR HOLE
- 836 BED STABILIZER DESIGN WITH SHEET PILE CUTOFF
- 837 ARS-TYPE GRADE CONTROL STRUCTURE WITH PRE-FORMED RIPRAP LINED STILLING BASIN AND BAFFLE PLATE
- 838 SCHEMATIC OF MODIFIED ARS-TYPE GRADE CONTROL STRUCTURE
- 839 CIT-TYPE DROP STRUCTURE
- 840 ST. ANTHONY FALLS (SAF) TYPE DROP STRUCTURE
- 841 CONTROL SILL GRADE CONTROL STRUCTURE
- 842 EXAMPLE: CROSS-SECTION OF DOE CREEK
- 843 DEGRADED CHANNEL PROFILE BY THE THREE-SLOPE METHOD

SECTION 800

OPEN CHANNELS

801 INTRODUCTION

Presented in this section are the technical criteria and design standards for the hydraulic evaluation and design of open channels. Discussion and standards are provided for the various channel linings and design sections anticipated to be encountered or used in the Washoe County area. Since the design of channel sections depends on site conditions, the “best” channel design can vary significantly within the Washoe County area. The ultimate responsibility for a safe and stable channel design rests with the designer.

The information presented in this section should be considered to be the minimum standards on which channel evaluation and design should be based. Additional analysis beyond the scope of this Manual may be necessary for unique or unusual channel conditions. In addition, the Jurisdictional Entity may require submittal of additional design and analysis information for any of the proposed channel sections and linings in order to assess the adequacy of the design for the proposed application. Therefore, the designer is recommended to contact the Jurisdictional Entity prior to design of an open channel to discuss additional requirements (if any) for the selected channel. If the designer is proposing a different channel design than presented in this section, the Jurisdictional Entity must be contacted prior to designing the channel.

802 OPEN CHANNEL HYDRAULICS

An open channel is a conduit in which water flows with a free surface (nonpressurized flow). The hydraulics of an open channel can be very complex, encompassing many different flow conditions from steady state uniform flow to unsteady, rapidly varying flow. Most of the problems in storm water drainage involve uniform, gradually varying or rapidly varying flow states. An example of these flow conditions is illustrated in Figure 801. The calculations for uniform and gradually varying flow are relatively straight forward and are based upon similar assumptions (i.e., parallel streamlines). Rapidly varying flow computations, (i.e., hydraulic jumps and flow over spillways) however, can be very complex and the solutions are generally empirical in nature.

Presented in this section are the basic equations and computational procedures for uniform, gradually varying and rapidly varying flow. The user is encouraged to review the many hydraulics textbooks available for more detailed discussions.

802.1 UNIFORM FLOW

Open channel flow is said to be uniform if the depth of flow is the same at every section of the channel. For a given channel geometry, roughness, discharge and slope, the only one possible depth for maintaining uniform flow is the normal depth. For uniform flow in a prismatic channel (i.e., uniform cross section), the water surface will be parallel to the channel bottom.

Uniform flow rarely occurs in nature and is difficult to achieve in a laboratory, because not all of the parameters remain exactly the same. However, channels are designed assuming uniform flow as an approximation, which is adequate for planning and design purposes.

The computation of uniform flow and normal depth shall be based upon Manning's formula as follows:

$$Q = (1.49/n)R^{2/3}S^{1/2}A \quad (801)$$

Where Q = Flow Rate [cubic feet per second (cfs)];
 n = Roughness coefficient;
 A = Area [square feet (sf)];
 P = Wetted perimeter (ft);
 R = A/P = Hydraulic radius (ft);
 S = Slope of the energy grade line (ft/ft).

For prismatic channels, the energy grade line (EGL) slope, hydraulic grade line (HGL) slope, and the bottom slope are assumed to be the same for uniform normal depth flow conditions.

Presented in Table 801 are equations for calculating many of the parameters required for hydraulic analysis of different channel sections. Table 802 provides a list of Manning's roughness coefficient values for many types of conditions that may occur in Washoe County. These parameters and the Manning's equation may also be readily computed using handheld calculators and personal computers.

802.2 UNIFORM CRITICAL FLOW ANALYSIS

The critical state of uniform flow through a channel is characterized by several important conditions.

1. The specific energy is a minimum for a given discharge.
2. The discharge is a maximum for a given specific energy.
3. The specific force is a minimum for a given discharge.
4. The velocity head is equal to half the hydraulic depth in a channel of small slope.
5. The Froude number is equal to 1.0.

If the critical state of uniform flow exists throughout an entire reach, the channel flow is critical and the channel slope is at critical slope, S_c . A slope less than S_c will cause subcritical flow. A slope greater than S_c will cause supercritical flow. A flow at or near the critical state is unstable. Factors creating minor changes in specific energy, such as channel debris, will cause a major change in depth.

The criteria of minimum specific energy for critical flow results in the definition of the Froude number (F_r) as follows:

$$F_r = V/(gD)^{1/2} \quad (802)$$

Where F_r = Froude number
 V = Velocity (ft/sec)
 g = Acceleration of gravity (32.2 ft/sec²)
 A = Channel flow area (sq ft)
 T = Top width of flow area (ft)
 D = A/T = Hydraulic depth (ft)

The Froude number for a given channel section and flow can be easily computed using the above equation. The critical depth in a given trapezoidal channel section with a known flow rate can be determined using the following methodology. First, the section factor, Z, is computed.

$$Z = Q/(g)^{1/2} \quad (803)$$

Where Z = Section factor
 Q = Flow rate (cfs)
 g = Acceleration of gravity (32.2 ft/sec²)

Utilizing values for Z, the channel bottom width, b, and the side slope, z, the critical depth in the channel, y, can be determined from Figure 802. For other prismatic channel shapes, Equation 803 above can be used with the section factors provided in Table 801 to determine the critical depth.

Since flows at or near critical depth are unstable, all channels shall be designed with Froude numbers and flow depths as follows:

<u>Flow Condition</u>	<u>Froude number (Fr)</u>	<u>Flow Depth</u>
Subcritical	<0.86	>1.1d _c
Supercritical	>1.13	<0.9d _c

where d_c=critical depth

All channel design submittals shall include the calculated Froude number and critical depth for each unique reach of channel to check the flow state and compliance with the Manual.

802.3 GRADUALLY VARYING FLOW

The most common occurrence of gradually varying flow in storm drainage is the backwater created by culverts, storm sewer inlets, or channel constrictions. For these conditions, the flow depth will be greater than normal depth in the channel and the water surface profile must be computed using backwater techniques.

Backwater computations can be made using the methods presented in Chow, 1959. Many computer programs are available for computation of backwater curves. The most general and widely used program is HEC-2 and/or HEC-RAS, water-surface profiles, developed by the U.S. Army Corps of Engineers. This program is recommended for floodwater profile computations for channel and flood plain analysis within the Washoe County area.

For prismatic channels, the backwater calculation can be computed manually using the Direct Step method as described in Chow, 1959. The Direct Step method is also available in many hand-held and personal computer software programs. For an irregular non-uniform channel, the Standard Step method can be a tedious and iterative process. For these channels, the use of HEC-2 and/or HEC-RAS is recommended.

802.4 RAPIDLY VARYING FLOW

Rapidly varying flow is characterized by very pronounced curvature of the flow streamlines. The change in curvature may become so abrupt that the flow profile is virtually broken, resulting in a state of high turbulence. There are mathematical solutions to some specific cases of rapidly varying flow, but empirical solutions are generally relied on for most rapidly varying flow problems. The most common occurrence of rapidly varying flow in storm drainage applications involves weirs and orifices, hydraulic jumps, non-prismatic channel sections (transitions, culverts and bridges), and non-linear channel alignments (bends). Discussions of rapidly varying flow for these applications are presented in this Manual as follows:

<u>Application</u>	<u>Section</u>
Weirs and Orifices	1300 - Detention
Hydraulic Jumps (Channels)	1200 - Additional Hydraulic Structures
Hydraulic Jumps (Conduits)	900 - Storm Sewer Systems
Culverts and Bridges	1100 - Culverts and Bridges
Channel Transitions and Bends	800 - Open Channels

Each of these flow conditions requires extensive and detailed calculations to properly identify the flow capacities and depths of flow in the given section. The designer should be cognizant of the design requirements for each of the above conditions and must include all necessary calculations as part of the design submittal documents. The designer is referred to the many hydraulic references for the proper calculation methods to use in the design of rapidly varying flow facilities.

802.5 TRANSITIONS

Channel transitions occur in open channel design whenever there is a change in channel slope, shape, and at junctions with other open channels or storm sewers. The goal of a good transition design is to minimize the loss of energy as well as minimizing surface disturbances from cross-waves and turbulence. A special case of transitions where excess energy is dissipated by design is drop structures and hydraulic jumps. Channel drop structures are discussed in Section 1200 (Additional Hydraulic Structures).

Transitions in open channels are generally designed for the following four flow conditions:

1. Subcritical flow to subcritical flow,
2. Subcritical flow to supercritical flow,
3. Supercritical flow to subcritical flow (Hydraulic Jump),
4. Supercritical flow to supercritical flow.

For definition purposes, conditions 1 and 2 will be considered as subcritical transitions and are discussed in Section 806.1 for subcritical flow. Conditions 3 and 4 will be considered as supercritical transitions and are discussed in Section 806.2 for supercritical flow.

803 CHANNEL SELECTION

803.1 CHANNEL TYPES

Essentially, open channels can be separated into 6 different categories:

803.1.1 NATURAL CHANNELS

Drainageways which are carved or shaped by nature before urbanization occurs. They often, but not always, have mild slopes and are reasonably stable. As the channel's tributary watershed urbanizes, natural channels often experience erosion and may need grade control checks and localized bank protection to stabilize.

803.1.2 GRASS-LINED CHANNELS

Among various types of constructed or modified drainageways, grass-lined channels are most desirable. They provide channel storage, lower velocities, and various multiple use benefits. Low flow areas may need to be concrete or rock-lined to minimize erosion and maintenance problems.

803.1.3 WETLAND BOTTOM CHANNELS

Wetland bottom channels are a subset of grass-lined channels that are designed to encourage the development of wetlands or certain types of riparian vegetation in the channel bottom. In low-flow areas the banks need rock lining to protect against undermining.

803.1.4 CONCRETE-LINED CHANNELS

Concrete-lined channels are high velocity artificial drainageways that are not encouraged in urban areas. However, in retrofit situations where existing flooding problems need to be solved and where right-of-way is limited, concrete channels may offer advantages over other types of open drainageways.

803.1.5 RIPRAP-LINED CHANNELS

Riprap-lined channels offer a compromise between a grass-lined channel and a concrete-lined channel. They can reduce right-of-way needs and maintenance attention as compared to grass-lined channels and avoid the higher cost of concrete-lined channels.

803.1.6 OTHER CHANNEL LINERS

A variety of artificial channel liners are on the market, all intended to protect the channel walls and bottom from erosion at higher velocities. These include gabion, articulated concrete blocks, concrete revetment mats formed by injecting concrete into double layer fabric forms, and various types of synthetic fiber liners. As with rock and concrete liners, all of these types are best considered for helping to solve existing urban flooding problems and are not recommended for new developments. Each type of liner has to be scrutinized for its merits, applicability, other community needs, long term integrity, maintenance needs and costs.

803.2 CHANNEL SELECTION

The actual selection must be based upon a variety of multi-disciplinary factors which include:

803.2.1 HYDRAULIC FACTORS

- (1) Slope of thalweg
- (2) Right-of-way
- (3) Capacity needed
- (4) Basin sediment yield
- (5) Topography
- (6) Ability to drain adjacent lands
- (7) Flow velocity

803.2.2 STRUCTURAL FACTORS

- (1) Cost
- (2) Availability of material
- (3) Areas for wasting excess excavated material
- (4) Seepage and uplift forces
- (5) Shear stresses
- (6) Pressures and pressure fluctuations
- (7) Momentum transfer

803.2.3 ENVIRONMENTAL FACTORS

- (1) Neighborhood character
- (2) Neighborhood aesthetic requirements
- (3) Need for new green areas
- (4) Street and traffic patterns
- (5) Municipal or county policies
- (6) Wetland mitigation
- (7) Wildlife habitat
- (8) Water quality enhancement

803.2.4 SOCIOLOGICAL FACTORS

- (1) Neighborhood social patterns
- (2) Neighborhood children population
- (3) Pedestrian traffic
- (4) Recreational needs

803.2.5 MAINTENANCE FACTORS

- (1) Life expectancy
- (2) Repair and reconstruction needs
- (3) Maintainability
- (4) Proven performance
- (5) Accessibility

803.2.6 REGULATORY FACTORS

- (1) Federal regulations
- (2) State regulations

- (3) Local regulations

803.3 MAXIMUM PERMISSIBLE VELOCITIES

The design of all channels in the Washoe County area shall be based on maximum permissible velocities. This method of design assumes that the given channel section will remain stable up to the stated maximum permissible velocity provided that the channel is designed in accordance with the provisions of this Manual. Presented in Table 803 are the maximum permissible velocities for natural or improved, unlined and lined channels in Washoe County. These values shall be used for all channel designs in the Washoe County area. If a higher velocity is desired, the design engineer must demonstrate to the satisfaction of the Jurisdictional Entity that the higher velocity would not endanger the health or safety of the public and would not increase operation and maintenance of the channel section.

For natural and improved unlined channels, a geotechnical report shall be submitted to the Jurisdictional Entity which addresses the existing soil material classification upon which the maximum permissible velocity was selected. Additional analysis may be required for natural channels or improved unlined channels to verify that the channel will remain stable based on the stated maximum permissible velocities or based on an equilibrium analysis of sediment transport within the channel segment.

The stated maximum permissible velocities are based on flow studies conducted by various governmental agencies and private individuals. The application of these velocities to actual site conditions is subject to proper design and competent construction of the channel sections. The design engineer shall be responsible for designing the channel section to remain stable at the final design flow rate and velocity.

804 NATURAL CHANNEL DESIGN

804.1 INTRODUCTION

Natural channel design and analysis may be required for a variety of reasons, including but not limited to altering drainage (flow rate, volume or location) to a natural channel, proposed encroachment upon a natural channel, natural channel rehabilitation, etc. Discussion with the Jurisdictional Entity should be held to determine what level of natural channel design and analysis will be appropriate for projects impacting natural channels.

Presented in this section are the typical natural open channel sections which are encountered in the Washoe County area. A graphical illustration of the typical design sections is presented in Figure 803. The selection of a design section for a natural channel is generally dependent on the value of the developable land versus the cost to remove said land from a flood plain. The costs for the removal depend on the rate of flow, slope, alignment, and depth of the channel as well as material and fill costs for construction of the encroachment. The design sections discussed herein vary from no encroachment to the level of encroachment at which point an improved channel (unlined or lined) becomes more economical.

The design standards presented in this section are the minimum standards by which natural channel analysis and design shall be completed within the Washoe County area. The channel designer is reminded that the ultimate responsibility for a safe and stable channel design lies solely with the engineer responsible for the design. Thus, the execution of this responsibility may require additional analysis and stricter standards than are presented in this section. In addition, the Jurisdictional Entity

may require additional design analysis be performed to verify the suitability of the proposed design for the location under consideration.

For natural channel sections, the engineer shall verify through stable channel (normal depth) calculations the stability of the flood plain to contain the major storm flows. If this analysis demonstrates erosion outside of the designated flow path (easement and /or right-of-way), then an analysis as per Sections 804.3, 804.4 and 804.5 is required.

804.1.1 NATURAL UNENCROACHED CHANNELS

Natural unencroached channels are defined as channels where overlot grading from the development process does not encroach into the 100-year flood plain of a given channel. Although the development does not alter the flow carrying capacity of the flood plain, it is necessary to ensure that the development is protected from movement of the flood plain boundaries due to erosion and scour. Therefore, the designer needs to identify the locations susceptible to erosion and scour and provide a design which reinforces these locations to minimize potential damage to the proposed development. For natural channels with velocities that exceed stable velocities, erosion protection may include construction of buried grade control/check structures to minimize headcutting and subsequent bank failures.

804.1.2 NATURAL ENCROACHED CHANNELS

Natural encroached channels are defined as channels where the development process has encroached into the 100-year flood plain fringe. This definition includes both excavation and fill in the flood plain fringe which maintains or decreases the water surface. The designer must prepare a design which will minimize damage to the development from movement of the flood plain boundaries due to erosion and scour. Consideration of erosion protection is similar to that for unencroached channels with emphasis on protection of the fill embankment. The provisions of the Jurisdictional Entities' Development code with respect to National Flood Insurance Program requirements also apply to these channels (see Section 303.6).

804.1.3 BANK-LINED CHANNELS

Bank-lined channels are channels where the banks will be lined but the channel bottom will remain in a natural state with minimal regrading. The concerns with bank-lined channels are to minimize scour of the channel bottom at the bank lining interface as well as maintaining a stable natural channel. The designer must prepare a design which addresses scour depths at the lining interface to assure that the lining extends below this depth to avoid undermining of the lining.

804.1.4 PARTIALLY LINED CHANNELS

Partially lined channels are defined as channels in which half of the channel is completed and the other half is left in a natural or unimproved condition. The concerns with partially lined channels are twofold. First, the improvement and lining of one side of the channel will cause changes to the hydraulic parameters of the unlined section which could increase erosion and scour in the unlined section. Second, floods which occur during the temporary condition may damage the improved channel section and require avoidable costly repairs.

Partially lined channels will only be allowed if:

- a) The bottom paving is bonded, or there is another mechanism in place to pay for the bottom paving once the channel is completed.
- b) Erosion in the unlined section is addressed to the satisfaction of the Jurisdictional Entity.

c) Scour below the lining is addressed to the satisfaction of the Jurisdictional Entity.

The analysis and design must demonstrate that the proposed temporary channel does not significantly adversely impact the hydraulic parameters and stability of the unlined section.

804.1.5 DISTURBANCES AFFECTING NATURAL CHANNELS

Natural stream systems typically function within natural ranges of flow, sediment movement, temperature, and other variables. They evolve in concert with and in response to the surrounding ecosystems. Normally, natural stream systems are in a state of “dynamic equilibrium”. When changes in system variables go beyond their normal ranges, the dynamic equilibrium may be upset, resulting in adjustments in the ecosystem that might be in conflict with societal needs. In some instances, a new dynamic equilibrium may eventually develop, but the time required to reach the new equilibrium may be lengthy. Both natural forces and human activities contribute to changes in the dynamic equilibrium of the natural stream system. It is essential for natural channel designers to understand the relationship between the causes and effects within natural stream systems, especially, the effects resulting from human activities.

Disturbances that affect the dynamic equilibriums in natural stream systems are natural events or human activities that occur separately or simultaneously. Either individually or in combination, disturbances place stresses on stream systems that have the potential to alter its structure and impair its ability to perform key ecological functions. The true impact of these disturbances can best be evaluated by understanding how they affect the ecosystem structure, processes, and functions.

A disturbance occurring within or adjacent to a watershed typically results in a causal chain of effects, which may permanently alter one or more characteristics of a stable system. The ideal goal is to find the root cause for which to plan and develop effective solution measures. Otherwise, solution measures may merely treat symptoms rather than the source of the problem.

Using this broad goal along with the thoughtful use of a responsive evaluation and design process will greatly reduce the need for trial-and-error experiences and enhance the opportunities for successful designs in natural stream systems.

804.1.5.1 Natural Forces

Floods, hurricanes, tornadoes, fire, lightning, volcanic eruptions, earthquakes, insects and disease, landslides, temperature extremes, and drought are among the many natural events that disturb structure and functions in the natural stream system. How natural stream systems respond to these disturbances varies according to their relative stability, resistance, and resilience. In many instances they reach a new dynamic balance with little or no need for human intervention.

804.1.5.2 Human Activities

Man-made disturbances resulting from land use activities undoubtedly have the greatest potential for introducing significant changes to the ecological structure and functions of stream systems. Many human activities that affect natural stream systems chemically, biologically and physically include agricultural practices, urbanization, mining operations, flood control, forest management, road building and maintenance.

Major specific man-made disturbances include: (a) Bridges, (b) Channelization, (c) Dams, (d) Dredging for Mineral Extract, (e) Hard Surfacing, (f) Irrigation and Drainage, (g) Land Grading, (h) Levees, (i) Overgrazing, (j) Piped Discharge, (k) Reduction of Flood Plain, (l) Road and Railroads, (m) Soil Exposures or Compaction, (n) Streambed Disturbance, (o)

Streambank Armoring (p) Trails, (q) Utility Crossing, (r) Vegetative Clearing, (s) Withdrawal of Water, and (t) Woody Debris Removal.

Potential direct and indirect effects of these disturbances are:

- (1) Channel widening and downcutting
- (2) Decreased capacity of flood plain and upland to accumulate, store, and filter materials and energy
- (3) Decreased capacity of stream to accumulate and store or filter materials and energy
- (4) Decreased groundwater inflow to stream
- (5) Decreased infiltration of surface runoff
- (6) Decreased interflow and subsurface flow
- (7) Decreased source of instream shade, detritus, food, and cover
- (8) Dense compacted soil
- (9) Increased bank failure
- (10) Increased flow velocities
- (11) Increased instream sediment, salinity, and turbidity
- (12) Increased levels of fine sediment and contaminants in stream corridor
- (13) Increased levels of sediment and contaminants reaching stream
- (14) Increased or decreased flow frequency
- (15) Increased or decreased stream stability
- (16) Increased peak flood elevation
- (17) Increased sheetflow with surface erosion, rill and gully flow
- (18) Increased stream gradient and reduced energy dissipation
- (19) Increased stream migration
- (20) Increased streambank erosion and channel scour
- (21) Increased upland surface runoff
- (22) Loss of associated wetland function including water storage, sediment trapping, recharge, and habitat
- (23) Reduced flow duration
- (24) Reduced groundwater recharge and aquifer volumes
- (25) Reduced stream meander

The relationship between the human activities and the potential effects are summarized in Table 804.

804.2 NATURAL CHANNEL MORPHOLOGY AND RESPONSE

Natural channel systems are not only runoff conveyances but also complex ecosystems with morphological characteristics that depend on appropriate geomorphic dimension, pattern, and profile

as well as biological and chemical integrity. In addition, stream functions also include the transport of water and sediment generated within the stream's watershed in dynamic equilibrium.

Generally, the position and shape of a natural channel system is continually changing due to hydraulic forces and related biological forces acting on its bed and banks. These changes, which may be a result of natural environmental changes or from human activities, can be slow or quick and often propagates long distances. When a natural channel is modified locally, the modification often causes changes in channel characteristics both upstream and downstream. Human-induced changes of natural channels often occur despite attempts to minimize impacts to the natural channel environment.

Despite the complexity of these responses, all natural channels are governed by the same basic forces. A natural channel can be designed on the basis of sufficient understanding of: 1) site geology, including soil conditions; 2) site hydrology, including possible changes in flow and runoff, and the hydrologic effects of changes in land use; 3) geometry of the stream system, including the probable geometric alterations that developments will impose on the channel; 4) hydraulic characteristics such as depth, slope, channel roughness, velocity of streams, sediment transport, and the changes that may be expected in these characteristics over time and space; and 5) ecological/biological changes resulting from physical changes that may in turn induce additional physical changes.

Many interrelated variables affect natural channels. Unlike rigid-boundary hydraulic problems, it is difficult to isolate and study the role of an individual variable. Due to the complexity of the processes occurring in natural channels that influence the erosion and deposition of sediment, a detached analytical approach to the problem is difficult and time consuming. Many empirical relations have been developed to describe natural channel processes. The major factors affecting natural channel morphology are: 1) stream discharge; 2) sediment load; 3) longitudinal slope; 4) characteristics of bed and bank material; 5) bank and bed resistance to flow; 6) vegetation or lack there of; 7) geology, including type of sediment; and 8) human works.

804.2.1 SLOPE

The energy gradient slope plays an important role in the hydraulics of natural channels. Slope appears in both velocity equations such as Manning's equation and in tractive force equations. A natural channel reach may be subject to a general lowering or rising of the bed level over time due to changing sediment supply conditions caused by activities such as urbanization, construction of a detention pond, etc. When the incoming supply is equal to the channel's sediment transporting capacity, the channel sediment transport is in equilibrium and the channel is at an equilibrium slope. Under this equilibrium condition, the channel neither aggrades nor degrades.

The equilibrium channel slope can be utilized to estimate the wash response to human induced changes. Its evaluation will provide an understanding of what will be the long-term effects on the channel profile of such measures as channelization or reducing sediment supply due to urbanization.

804.2.2 DEGRADATION AND AGGRADATION

Degradation is the lowering of a streambed by scour and erosion and aggradation is the excessive accumulation of sediment that results in raising the streambed elevation. A channel reach may be subject to a general degradation or aggradation over a fairly long period of time. Accurate estimation of degradation and aggradation is important; otherwise foundation depths may be inadequate or excessive depending on the magnitude of degradation or aggradation.

To determine a condition of degradation or aggradation is to compare in a reach, the sediment supply and the sediment transport. When sediment supply is less than sediment transport, the flow will remove extra sediment from the channel bed and/or banks resulting in degradation of the channel bed

and possible failure of the banks. If the supply entering the reach is greater than the transport capacity, the excessive supply will be deposited resulting in aggradation. Currently the best method of estimating the general degradation and aggradation of a stream system is by utilizing a sediment routing model on a reach by reach basis (e.g., QUASED by Simons, Li & Associates; HEC-6 by USACE; FLUVIAL by Howard Chang; ONETWOD by Y.H. Chen). However, less demanding methods using rigid bed hydraulic and sediment transport calculations may be used to evaluate the balance between sediment supply and transport.

The determination of sediment transport as presented below is an easy-to-apply power relationship between sediment transport rate, velocity and depth as follows:

$$q_s = C_1(Y)^{C_2}(V)^{C_3} \tag{804}$$

where, q_s is sediment transport rate per unit width (cfs/ft); Y is flow depth (ft); V is flow velocity (ft/sec); and C_1, C_2, C_3 are constants.

Values of C_1, C_2 and C_3 for sand materials are presented in Table 805 with limitations noted. These power relations were developed from a numerical solution of the Meyer-Peter and Muller bed-load transport equation and Einstein's integration of the suspended bed-material discharge (Simons, Li & Associates, 1982). For flow conditions within the ranges presented in Table 806, the regression equation is accurate within 10 percent.

Determination of the equilibrium channel slope is a key step in designing stable channels. Equation (804) can be used to determine the equilibrium channel slope by combining it with Manning's equation:

$$q = \frac{1.486}{n}(R)^{5/3}(S_e)^{1/2} \tag{805}$$

Where: q is flow discharge per unit width (cfs/ft); n is Manning's roughness coefficient; R is hydraulic radius in (ft), approximated by Y for wide channels; and S_e is energy slope.

Substituting equation (805) into equation (804) and solving for depth yields:

$$q_s = C_1(q)C_3 \left[\frac{qn}{1.486S_e^{1/2}} \right]^{3/5(C_2-C_3)} \tag{806}$$

Rearranging and solving for slope results in:

$$S_e = \left(\frac{C_1}{q_s} \right)^{\frac{10}{3(C_2-C_3)}} \frac{2(3C_2+2C_3)}{(q)^{\frac{2(3C_2+2C_3)}{3(C_2-C_3)}}} \left(\frac{n}{1.486} \right)^2 \tag{807}$$

For a given upstream supply, channel roughness and sediment transport parameters, equation (807) reduces to a simple function of unit discharge. This equation can be utilized to estimate long-term degradation and aggradation.

Due to the relatively few rainstorms which occur each year within the Washoe County area, the long term degradation or aggradation is expected to be primarily caused by the major storms. Similarly, the minor storms are expected to only produce minor changes in degradation or aggradation in the Washoe

County area. Therefore, the major storm event (100-year) shall be used for analysis of the equilibrium slope and this will provide an adequate capacity for events greater than the design discharge.

804.2.3 ANTI-DUNE TROUGH DEPTH

Anti-dunes are bed forms in the shape of dunes which move in an upstream direction within the channel; hence the term “anti-dunes”. They form as trains of waves that build up from a plane bed and a plane water surface. Anti-dunes can form either during transitional flow, between subcritical and supercritical flow, or during supercritical flow. The wave length is proportional to the flow velocity. The corresponding surface waves, which are in phase with the anti-dunes, are likely to break like surf when the waves reach a height of approximately 14 percent of the wave length. A relationship between anti-dune trough depth, Z_a , and average channel velocity, V (Simons, Li & Associates, 1982) is:

$$z_a = \frac{1}{2}(0.14) \frac{2\pi V^2}{g} = 0.0137V^2 \tag{808}$$

A limitation on equation (808) is that the anti-dune trough depth can never exceed one-half the depth of flow. Therefore, if the calculated value of Z_a obtained by using equation (808) is greater than one-half of the depth of flow, the anti-dune trough depth should then be taken as one-half of the depth of flow.

804.2.4 BEND SCOUR

Bend scour typically occurs along the outside of bends, and is caused by spiral, transverse currents which form within the flow as the water moves through the bend. Currently, no single procedure will consistently and accurately predict bend scour over a wide range of hydraulic conditions. Zeller has developed the following relationship for estimating bend scour in sand-bed channels assuming constant stream power within the channel bend (Simons, Li & Associates, 1989):

$$Z_{bs} = \frac{0.0685Y_{MAX} V^{0.8}}{Y_h^{0.4} S_e^{0.5}} \left[2.1 \left[\frac{\sin^2(a/2)}{\cos a} \right]^{0.2} - 1 \right] \tag{809}$$

Where, Z_{bs} is bend scour component of total scour depth, in ft; ($Z_{bs} = 0$, when $r_c/T \geq 10.0$, or $\alpha \leq 17.8^\circ$; Z_{bs} = calculated value, when $0.5 < r_c/T < 10.0$, or $17.8 < \alpha < 60^\circ$; Z_{bs} = calculated value, when $r_c/T \leq 0.5$, or $\alpha \geq 60^\circ$); V is the average velocity of flow immediately upstream of bend, in ft/sec; Y_{MAX} is the maximum depth of flow immediately upstream of bend, in ft; Y_h is the hydraulic depth of flow immediately upstream of bend, in ft (Hydraulic depth = Flow Area/Flow Top Width); S_e is the energy slope immediately upstream of bend (or bed slope for uniform-flow conditions); and α is the angle formed by the projection of the channel centerline from the point of curvature to a point which meets a line tangent to the outer bank of the channel, in degrees (see Figure 804).

For a circular curve, the following relationship can be derived between α and the ratio of the centerline radius of curvature, r_c , to channel top width, T :

$$\frac{r_c}{T} = \frac{\cos(a)}{4 \sin^2(a/2)} \tag{810}$$

If the bend deviates significantly from a circular curve, the curve should be divided into a series of circular segments, and the bend scour can be calculated for each segment based on the corresponding angle α for that segment.

Equations (809) and (810) can be utilized to estimate the scour depth in a bend for a specific water discharge. The impact that other simultaneously occurring phenomena such as sand waves, local scour, long-term degradation, etc., might have on bend scour is not well understood, given the present state of the art. Therefore, in order to avoid underestimating the maximum bend scour, it is recommended that bend scour be treated as an independent channel adjustment that should be added to those adjustments calculated for long-term degradation, contraction, and sand-wave troughs.

The longitudinal extent of the bend-scour is as difficult to quantify as the vertical extent. Rozovskii developed a relationship for estimating the distance from the end of a bend at which the secondary currents will have decayed to a negligible magnitude. This relationship, in a simplified form, is:

$$X = \frac{0.6}{n} Y^{1.17} \quad (811)$$

where, X is the distance from the end of channel curvature (point of tangency, PT) to the downstream point at which secondary currents have dissipated, in ft; n is Manning's roughness coefficient; Y is depth of flow (to be conservative, use maximum depth of the flow, exclusive of scour, within the bend), in ft.

Equation (811) should be used for determining the distance downstream of a curve that secondary currents will continue to be significant in producing bend scour. For a conservative estimate of the longitudinal extent of bend scour, both through and downstream of the bend, it is recommended that bend scour be considered as commencing at the upstream point of curvature, PC, and extending a distance, X, (calculated from Equation 811) beyond the downstream point of tangency, PT. Hydraulic Engineering Circular No. 11 contains additional guidance on flow and scour protection with bends, and may be used as an additional design reference.

804.2.5 CONTRACTION SCOUR

Contraction scour occurs when the flow area is contracted by embankments, channelization, bridges and/or accumulation of debris. Scour at contractions occurs because the flow area reduces and average velocity and bed shear stress increase. As a result, stream power at the contraction increases and more bed material is transported through the contracted section than is transported into the section. As bed level is lowered, banks erode; velocity and shear stress decrease and a new equilibrium condition is reached when the transport rate of the sediment through the contracted section is equal to the incoming supply rate.

Contraction scour can be divided into two types depending on how much bed material is being transported upstream of the contraction reach. They are: live-bed contraction scour and clear-water contraction scour. Live-bed contraction scour occurs when bed material is already being transported into the contracted section from upstream of the approach section (before the contraction reach). Clear-water contraction scour occurs when the bed material sediment transport in the uncontracted approach section is negligible or less than the carrying capacity of the flow.

To determine which type of scour is dominating (i.e., live-bed contraction scour, or clear-water contraction scour), a critical velocity for beginning of motion, V_c , (for the D_{50} size of bed material) can be calculated and compared with the mean velocity, V , of the flow in the main channel or overbank area upstream of the contraction reach. If the critical velocity of the bed material is less than the mean velocity at the approach section, $V_c < V$, then live-bed contraction scour is assumed. If the critical velocity of the bed material is greater than the mean velocity at the approach section, $V_c > V$, the clear-water contraction scour is assumed. Equation (812) developed by Laursen (1963) can be used to calculate the critical velocity:

$$V_c = 10.95Y^{(1/6)}d_{50}^{(1/3)} \quad (812)$$

where, V_c is the critical velocity above which material of size d_{50} and smaller will be transported, in ft/sec; Y is the average depth of flow in the main channel or overbank area at the approach section, in ft, d_{50} is the bed material size in a mixture of which 50 percent are smaller, in ft.

804.2.5.1 Live-Bed Contraction Scour

The hydraulic Engineering Circular No. 18 (HEC No. 18, FHWA, 2001) recommends using a modified version of Laursen's (1960) equation to estimate live-bed contraction scour:

$$Y_2 = Y_1 \left[\frac{Q_2}{Q_1} \right]^{6/7} \left[\frac{W_1}{W_2} \right]^{K_1} \quad (813)$$

$$Z_{cs} = Y_2 - Y_0 \quad (814)$$

where, Z_{cs} is the average depth of contraction scour, in ft; Y_2 is the average depth after scour in the contracted section, in ft; Y_1 is the average depth in the main channel or flood plain at the approach section, in ft; Y_0 is the average depth in the main channel or flood plain at the contracted section before scour, in ft; Q_1 is the portion of the flow in the main channel or flood plain at the approach section, which is transporting sediment, in cfs; Q_2 is the portion of the flow in the main channel or flood plain at the contracted section, which is transporting sediment, in cfs (Q_2 is greater than Q_1 approximately by the amount of flow blocked by the structure causing channel contraction); W_1 is the top width of the active flow area at the approach section; W_2 is the top width of the active flow area at the contracted section; K_1 is the exponent for mode of bed material transport [(1) $V^*/\omega < 0.5$, $K_1 = 0.59$, mostly contact bed material discharge; (2) $V^*/\omega = 0.5$ to 2.0 , $K_1 = 0.64$, some suspended bed material discharge; (3) $V^*/\omega < 2.0$, $K_1 = 0.69$, mostly suspended bed material discharge.]; $V^* = (gY_1S_e)^{1/2}$, is the shear velocity in the main channel or flood plain at the approach section, in ft/sec; ω is the fall velocity of bed material based on d_{50} , in ft/sec (see Stokes Equation, p. 73-77, Fluvial Processes in River Engineering, H. Chang, 1998); g is gravitational acceleration, in ft/sec²; S_e is the slope of the energy grade line at the approach section.

804.2.5.2 Clear-Water Contraction Scour

The clear-water contraction scour equation recommended by the HEC No. 18 is also an equation based on Laursen's (1963) work:

$$Y_2 = \left[\frac{Q_2^2}{Cd_m^{2/3}W_2^2} \right]^{3/7} \quad (815)$$

$$Z_{cs} = Y_2 - Y_0 \quad (816)$$

Where, d_m is the diameter of the smallest non-transportable particle in the bed material ($1.25 d_{50}$) in the contracted section, in ft; $C = 120$ for English units (40 for metric).

804.2.6 LOCAL SCOUR

Local scour occurs at bridge abutments and piers. The basic mechanism causing local scour are flow jets which result from the backup of water on the upstream edge of the embankment and piers and

subsequent acceleration of this flow around the nose of the embankment. The effect of the jet is to erode bed materials away from the base area. If the transport rate of sediment away from the local area is greater than the transport rate into the area, a scour hole develops. As the depth increases, the strength of the flow jet and the sediment transport rate reduce, equilibrium is re-established and scouring ceases.

804.2.6.1 Local Scour at Abutments

Local scour occurs at abutments when the abutment obstructs flow. The obstruction of flow forms a horizontal vortex starting at the upstream end of the abutment and running along the toe of the abutment, and forms a vertical wake vortex at the downstream end of the abutment.

The HEC Circular No. 18 recommends two equations for the calculation of live-bed abutment scour. When the wetted embankment length (L') divided by the approach flow depth (Y_1) is greater than 25, the HEC Circular No. 18 suggests using the HIRE equation (Richardson, 1990). When the wetted embankment length divided by the approach depth is less than or equal to 25, the HEC Circular No. 18 suggests using an equation developed by Froehlich (Froehlich, 1989).

The HIRE equation is based on field data of scour at the end of spurs in the Mississippi River (obtained by the USACE). The HIRE equation is:

$$Z_s = 4Y_1 \left(\frac{K_1}{0.55} \right) K_2 Fr_1^{0.33} \tag{817}$$

where: Z_s is the scour depth in ft; Y_1 is the depth of flow at the toe of the abutment on the overbank or in the main channel, ft (m), taken at the cross section just upstream of the bridge; K_1 is the correction factor for abutment shape ($K_1=1.00$, for vertical-wall abutment; $K_1=0.82$, for vertical-wall abutment with wing walls; and $K_1=0.55$, for spill-through abutment); K_2 is the correction factor for angle of attack (θ) of flow with abutment, $\theta = 90^\circ$, when abutments are perpendicular to the flow, $\theta < 90^\circ$, if embankment points downstream, and $\theta > 90^\circ$, if embankment points upstream; $K_2 = (\theta/90)^{0.4}$; Fr_1 is Froude number based on velocity and depth adjacent and just upstream of the abutment toe.

Froehlich analyzed 170 live-bed scour measurements in laboratory flumes by regression analysis to develop the following equation:

$$Z_s = 2.27K_1K_2(L)^{0.43} Y_a^{0.57} Fr^{0.61} + Y_a \tag{818}$$

where: Z_s is scour depth in ft; K_1 is the correction factor for abutment shape ($K_1=1.00$, for vertical-wall abutment; $K_1=0.82$, for vertical-wall abutment with wing walls; and $K_1=0.55$, for spill-through abutment); K_2 is the correction factor for angle of attack (θ) of flow with abutment, $\theta = 90^\circ$, when abutments are perpendicular to the flow, $\theta < 90^\circ$, if embankment points downstream, and $\theta > 90^\circ$, if embankment points upstream; $K_2 = (\theta/90)^{0.4}$; L is the length of abutment (embankment) projected normal to flow, in ft; Y_a is the average depth of flow on the flood plain at the approach section, in ft; Fr is the Froude number of the flood plain flow at the approach section, $Fr = V_a/(gY_a)^{1/2}$, V_a is the average velocity of the approach flow $V_a = Q_a/A_a$, in ft/sec; Q_a = Flow obstructed by the abutment and embankment at the approach section, cfs; A_a is the flow area of the approach section obstructed by the abutment and embankment, in ft^2 .

The above form of the Froehlich equation is for design purposes. The average depth at the approach section, Y_a , was added to the equation in order to envelope 98 percent of the data. If the equation is to be used for analysis purposes (i.e. for predicting the scour of a particular event), Froehlich suggests dropping the addition of the approach depth (+ Y_a).

804.2.6.2 Local Scour at Pier

Pier scour occurs due to the acceleration of flow around the pier and the formation of flow vortices (known as the horseshoe vortex). The horseshoe vortex removes material from the base of the pier, creating a scour hole. As the depth of scour increases, the strength of the horseshoe vortex decreases, thereby reducing the rate at which material is removed from the scour hole. Eventually equilibrium between bed material inflow and outflow is reached, and the scouring ceases.

The HEC Circular No. 18 recommends the use of the Colorado State University (CSU) equation (Richardson, 1990) for the calculation of pier scour under both live-bed and clear-water conditions. Another relationship developed by Froehlich (1991) provides an alternative pier scour equation. The Froehlich equation is not recommended in the HEC Circular No. 18, but has been shown to agree well with observed data.

The CSU equation calculates maximum pier scour depths for both live-bed and clear-water pier scour. The equation is:

$$Z_s = 2.0K_1K_2K_3K_4a^{0.65}Y_1^{0.35}Fr^{0.43} \tag{819}$$

where: Z_s is the depth of scour in feet; K_1 is the correction factor for pier nose shape [$K_1=1.1$, for square nose; $K_1=1.0$, for round nose, circular cylinder and group of cylinders; and $K_1=0.9$, for sharp nose (triangular)]; K_2 is the correction factor for angle of attack of flow [$K_2=[(L/a)\sin \theta + \cos \theta]^{0.65}$, where L is the length of the pier along the flow line in ft, and θ is the angle of attack of the flow, with respect to the pier. If L/a is larger than 12, use $L/a = 12$ as a maximum for estimating K_2 . If the angle of attack is greater than 5°, K_2 dominates and K_1 should be set to 1.0.]; K_3 is the correction factor for bed condition [$K_3=1.1$, for clear-water scour, plane bed, anti-dune flow, and small dunes [$2 \leq H$ (dune height) < 10]; $K_3=1.1 \sim 1.2$, for medium dunes ($10 \leq H < 30$); $K_3=1.3$, for large dunes ($H \geq 30$)]; K_4 is the correction factor for armoring of bed material (K_4 decreases scour depths for armoring of the scour hole for bed materials that have a d_{50} equal to or larger than 0.20 ft. The correction factor results from recent research by A. Molinas at CSU which showed that when the velocity (V_1) is less than the critical velocity (V_{c90}) of the d_{90} size of the bed material, and there is a gradation in sizes in the bed material, the d_{90} will limit the scour depth. The equation developed by J. S. Jones from analysis of the data is:

$$K_4 = [1 - 0.89(1 - V_R)^2]^{0.5} \tag{820}$$

where:

$$V_R = \frac{V_1 - V_i}{V_{c90} - V_i} \tag{821}$$

$$V_i = 0.645 \left[\frac{d_{50}}{a} \right]^{0.053} V_{c50} \tag{822}$$

V_R is the velocity ratio; V_1 is the average velocity in the main channel or overbank area at the cross section just upstream of the bridge, ft/sec; V_i is the velocity when particles at a pier begin to move, ft/sec; V_{c90} is the critical velocity for d_{90} bed material size, in ft/sec ($V_{c90} = 10.95 Y^{1/6} d_{90}^{1/3}$); V_{c50} is the critical velocity for d_{50} bed material size, in ft/sec ($V_{c50} = 10.95 Y^{1/6} d_{50}^{1/3}$); a is the pier width, in ft; Y_1 is the depth of water just upstream of the pier, in ft; Fr_1 is the Froude number directly upstream of the pier.

Limiting K_4 values and bed material size are:

$$K_4 \geq 0.7; V_R \geq 1.0; d_{50} \geq 0.2\text{ft.}$$

A local pier scour equation developed by Froehlich (Froehlich, 1991) has been shown to compare well with observed data (FHWA, 1996). The equation is:

$$Z_s = 0.32\Phi(a')^{0.62} Y_1^{0.47} Fr_1^{0.22} d_{50}^{-0.09} + a \quad (823)$$

where, Φ is the correction factor for pier nose shape: $\Phi = 1.3$ for square nose piers, $\Phi = 1.0$ for rounded nose piers, and $\Phi = 0.7$ for sharp nose (triangular) piers; a' is projected pier width with respect to the direction of the flow, in ft.

Equation (823) is used to estimate maximum pier scour for design purposes. The addition of one pier width ($+ a$) is placed in the equation as a factor of safety. If the equation is to be used for analysis (i.e. for estimating the scour of a particular event), Froehlich suggests dropping the addition of the pier width ($+ a$). The pier scour calculated from equation (823) is limited to a maximum in the same manner as equation (819) (the CSU equation). Maximum scour $Z_s \leq 2.4$ times the pier width (a) for $Fr_1 \leq 0.8$, and $Z_s \leq 3.0$ times the pier width (a) for $Fr_1 > 0.8$.

804.2.7 TOTAL SCOUR

The total scour that can occur at a structure is equal to the combination of long-term bed elevation changes, one-half of anti-dune trough depth, bend scour, contraction scour and local scour:

$$Z_t = Z_{lt} + (1/2)Z_a + Z_{bs} + Z_{cs} + Z_s \quad (824)$$

where,

- Z_t = total scour
- Z_a = anti-dune trough depth
- Z_{bs} = bend scour
- Z_{cs} = contraction scour
- Z_s = local scour
- Z_{lt} = long term bed elevation

Bank protection and protection at structures should extend to a depth below the channel bed to the total scour.

804.2.8 SCOUR BELOW CHANNEL DROPS

Scour below channel drops, such as grade-control structures, is a special case of local scour. Where the drop consists of a free, unsubmerged overfall, the depth of scour below the drop can be calculated by using equation (825) (U.S. Bureau of Reclamation, 1977):

$$Z_{fd} = 0.32q^{0.54}H_t^{0.255} - T_w \quad (825)$$

Where, Z_{fd} is depth of local scour due to a free overall drop, in ft, measured below the streambed surface downstream of the drop; q is discharge per unit width of the channel bottom, in cfs/ft; H_t is total drop in head, measured from the upstream energy grade line to the downstream energy grade line, in ft; T_w is tailwater elevation or depth (downstream water-surface elevation or depth), in ft.

Where the drop is submerged, as will be the case for most instances involving grade-control structures placed along watercourses, the depth of scour below the drop can be calculated by using equation (826) (Simons, Li & Associates, 1986):

$$Z_{sd} = 0.581q^{0.667}(h/Y)^{0.411}[1-h/Y]^{-0.118} \quad (826)$$

Where, Z_{sd} is depth of local scour due to a submerged drop, in ft, measured below the streambed surface downstream of the drop; q is discharge per unit width of the channel bottom, in cfs/ft; h is drop height, above the immediate downstream bed, in ft; Y is t downstream depth of flow, in ft (Note: $h/Y \leq 0.99$).

If $h/Y > 0.85$, the predicted scour below a channel drop should be calculated using both equations (825) and (826). The smaller value should then be used for design purposes.

The longitudinal extent of a scour hole created by either a free or submerged overfall is represented by the distance from the drop to the deepest scour depth, X_s , and the distance from the drop to the end of the scour hole, L_s . These distances can be estimated by the following equations:

$$X_s = 6.0Z_{fd} \text{ or } 6.0Z_{sd} \quad (827)$$

$$L_s = 12.0Z_{fd} \text{ or } 12.0Z_{sd} \quad (828)$$

Bank protection for toe-downs downstream of a grade-control structure shall extend to the calculated depth of scour for a distance equal to X_s beyond the grade-control structure. They shall then taper back to the normal toe-down depth within a total distance downstream of the grade-control structure equal to L_s .

When bridge piers and/or abutments are absent, the depth of scour below grade-control structures is not added to the other scour components. Instead, the depth of scour caused by the grade-control structure is compared with the depth of scour calculated for the long-term degradation, and the larger value is then used for the toe-down design.

804.3 NATURAL CHANNEL DESIGN

804.3.1 DESIGN APPROACHES

Design of natural channels is evolving. Therefore, this design Manual lists all the major design methods instead of specifying a particular method. Each method has advantages and limitations. The design engineer should make the appropriate selection based on the problem at hand and available information as well as the design purposes.

Approaches to design natural channels can be grouped into three broad categories:

Analog Approach which adopts templates from historic or adjacent channel characteristics and assumes equilibrium between channel form and sediment and hydrologic inputs.

Empirical Approach which uses equations that relate various channel characteristics derived from regionalized or “universal” data sets, and also assumes equilibrium conditions.

Analytical Approach which makes use of hydraulic models and sediment transport functions to derive equilibrium conditions, and thus is applicable to situations where historic or current channel conditions are not in equilibrium with existing or predicted sediment and hydrologic inputs.

804.3.1.1 Analog Approach

Four methods of application of the analog approach are:

The reference reach method (Rosgen 1996) includes measurement and subsequent replication of a number of channel parameters, including width, depth, slope, bed material gradation, flood prone width, and sinuosity, among others.

The carbon copy method relies on replication of previous or historic channel characteristics [Federal Interagency Stream Restoration Working Group (FISRWG), 2001].

Target or component analog method uses specific components of an existing channel as templates for achieving desired conditions within a reach.

Cross-section analog method uses cross-sections from stable reaches to estimate dominant discharge (bankfull discharge) and sediment transport character.

804.3.1.2 Empirical Approach

The empirical approach is also referred to as the “Hydraulic Geometry Method”. Empirical relationships based solely on experience or observation represent average conditions by reducing the range of variables from many observations to predictive formulas.

FISRWG (2001) provides comprehensive lists of valuable empirical relations and the regions from which their data sets were derived. Empirical equations can be used to determine the primary design variables (e.g., channel width), from which other components of design are derived. Empirical relations are only applicable over the range of conditions from which they were developed. Even when the conditions for sites used to generate an empirical equation match the design condition, the wide range of confidence limits remains a problem for designers. Confidence intervals for estimates from hydraulic geometry formulas often span an order of magnitude.

One of the regime equations for the determination of stable channel dimensions incorporated in SAM (Thomas, et. al., 2002) is the Bleach (1970) regime equations [(829), (831) and (832)]. The equations were intended for design of canals with sand beds.

The basic three channel dimensions, width, depth and slope are calculated as a function of bed-material grain size, channel-forming discharge, bed-material sediment concentration, and bank composition.

$$W = [(F_B Q) / F_S]^{0.5} \tag{829}$$

$$F_B = 1.9(d_{50})^{0.5} \tag{830}$$

$$D = \left[(F_S Q) / F_B^2 \right]^{1/3} \quad (831)$$

$$S = F_B 0.875 / \left[3.63gW^{0.25}D^{0.125} (1 + C / 2.330) / v^{0.25} \right] \quad (832)$$

where,

W = channel width (ft)

F_B = bed factor

F_S = side factor

Q = water discharge (cfs)

D₅₀ = median grain size of bed material (mm)

D = slope

C = bed-material sediment concentration (ppm)

g = acceleration of gravity (32.2 ft/sec²)

v = kinematic viscosity (ft²/sec)

The results are true regime values only if Q is the channel forming discharge. However, a width, depth and slope will be calculated for any discharge by these equations.

Bleach suggests that the following values be used for the side factor:

F_S = 0.1 for friable banks

F_S = 0.2 for silty, clay, loam banks

F_S = 0.3 for tough clay banks

In order to calculate the Bleach regime dimensions, the side factor, bed-material sediment concentration, and the bed-material gradation should be known.

The use of empirical equations to design channel attributes is not appropriate under the following conditions (Skidmore, et. al., 2002):

1. Aggrading, degrading, or unstable channels;
2. Site constraints that limit planform amplitude;
3. Where property or infrastructure protection requirements preclude the free migration of channel planform over time; and
4. Equations that do not specifically consider sediment transportation are applicable only to channels with relatively low bed load.

In summary, hydraulic geometry relationships are useful for preliminary or trial selection of design channel properties. Hydraulic and sediment transport analyses are recommended for final design.

804.3.1.3 Analytical Approach

Analytical approaches rely on the solution of physically based governing equations and generally require quantification of independent variables to determine channel parameters. Analytical approaches are also referred to as “process-based”.

Analytical methods are most valuable in their ability to estimate independent variables and to derive dependent variables when analogs and empirical relations are unavailable or inappropriate. Analytical methods can be applied to determine sediment load (if alluvial),

sediment budget, and channel geometry dimensions. They can be utilized to test long-term vertical stability of design conditions and allowable shear and velocity. They can also be employed for cross checking designs developed using analog or empirical approaches to account for the assumed conditions of equilibrium.

Numerous analytical methods have been developed (FISRWG, 2001) to address various components of channel design. Analytical design requires careful consideration of the applicability of the selected methodology to project site specific conditions. In the SAM hydraulic design package, for example, twenty sediment transport functions are available, each of which is appropriate only under specific conditions and for limited ranges of sediment grain size. The twenty functions are: Ackers-White; Ackers-White, D50; Brownlie, D50; Colby; Einstein (Bed-Load); Einstein (Total-Load); Engelund-Hansen; Laursen (Copeland); Laursen (Madden), 1985; Meyer-Peter and Muller (MPM), 1948; MPM (1948), D50; Parker; Profitt (Sutherland); Schoklitsch; Toffaleti; Toffaleti-MPM; Toffaleti-Schoklitsch; Yang; Yang, D50; and Van Rijn. This is not an exhaustive list of transport functions.

804.3.1.4 Modeling

a) Computer Models

Various computational models (CHARIMA, HEC-6, GSTARS 2.0, FLUVIAL-12, etc.) can be employed for iterative design and/or for checking the validity of proposed designs in terms of sediment transport. FISRWG (2001) summarizes eight computational models, which include: CHARIMA (Holly et al., 1990), FLUVIAL-12 (Chang, 1990), HEC-6, TABS-2 (McAnally and Thomas, 1985), MEANDER (Johannesson and Parker, 1985), the Nelson/Smith-89 model (Nelson and Smith, 1989), D-O-T (Darby and Thorne, 1996; Osman and Thorne, 1988), GSTARS (Molinas and Yang, 1986) and GSTARS 2.0 (Yang et al., 1998).

With the exception of MEANDER, all the above listed models calculate at each computation node the fractional sediment load and rate of bed aggradation or degradation and update the channel topography. Some can simulate armoring of the bed surface and hydraulic sorting (mixing) of the underlying substrate material. CHARIMA, FLUVIAL-12, HEC-6, and D-O-T are capable of simulating transport of sands and gravels. TABS-2 can be applied to cohesive sediments (clays and silts) and sand sediments that are well mixed over the water column. GSTARS 2.0 has the capability to simulate bank failure.

b) Physical Models

In some instances, channel designs can become extremely complex to exceed the capabilities of available computational models. In other situations, time might be the constraint, precluding the development of new computational modeling capabilities. In such cases, the designer must resort to physical modeling for verification.

Depending on the scaling criteria used to achieve similarity, physical models can be classified as distorted, fixed, or movable bed models. Physical modeling, like computational modeling, is a technology that requires highly specialized expertise and experience. Its application may be limited to only projects of great significance.

804.3.2 CHANNEL FORMING DISCHARGE

The channel-forming or dominant discharge is a theoretical constant discharge which would produce the same channel geometry as that produced by the long-term natural hydrograph. Determination of

accurate channel forming discharge/dominant discharge rate for a given channel system can be complex. Previous research efforts to relate dominant discharge rate to bankfull discharge, recurrence intervals, or effective discharge rate have been inconclusive. However, research and studies have concluded that the channel forming discharge rate varies between 1-year and 5-year storm flow rates [Leopold and Maddock (1953), Wolman and Leopold (1957), Dury (1973), Pickup and Warner (1976), Richards (1982), Leopold (1994), etc.].

In the Washoe County area, for simplicity and to achieve consistency in the design of natural channels, it is recommended that the low-flow channel section be designed to handle the estimated 2-year peak flows with no freeboard. The equilibrium slope for the purpose of designing natural channels should be determined based on the 2-year design storm flows (pre- and post-development conditions). In addition, the natural channel design should be checked for the 100-year storm event to ensure that the channel section will be stable during and after a major storm event (pre- and post-development conditions).

804.3.3 DESIGN DETAILS

Natural channel width varies continuously in the longitudinal direction and depth; bed slope and bed material size vary continuously along the horizontal plane. These variations result in natural heterogeneity and patterns of velocity and bed sediment size distribution.

Widths, depths and slopes calculated during design should be considered as reach average values, and designed channels should be constructed with asymmetric cross sections. Similarly, meander planform should vary from bend to bend. A designed flood plain does not need to be completely flat.

804.3.3.1 Stability Assessment

The risk of a designed channel being damaged by erosion or deposition is an important consideration in channel design. Designers of natural channels are confronted with fairly high uncertainty. In some cases, it may be wise for designers to estimate the overall risk of failure by calculating the joint probability of design assumptions being false, design equation inaccuracy, and occurrence of extreme hydrologic events during project life. Sound design practice also includes checking channel performance at discharges well above and below the design condition. Many approaches are available for checking both the vertical (bed) and horizontal (bank) stability of a designed channel. These stability checks are an important part of the design process.

a) Vertical (Bed) Stability

Bed stability, in general, is a prerequisite for bank stability. Aggrading channels are prone to braid or exhibit accelerated lateral migration in response to middle or point bar growth. Degrading channels widen suddenly when bank heights and angles exceed critical thresholds. Bank aggradation can be addressed by stabilizing eroding channels upstream, controlling erosion on the contributing watershed, or installing sediment traps, ponds. If aggradation is primarily due to deposition of fine sediments, it can be addressed by narrowing the channel, although a narrower channel might require more bank stabilization.

If bed degradation is occurring or expected to occur, the design should include flow modification, grade control measures, or other measures that reduce the energy gradient or the energy of flow. There are many types of grade control structures. The applicability of a particular type of structure to a specific design depends on a number of factors, such as hydrologic conditions, sediment size and loading, channel morphology, flood plain and valley

characteristics, availability of construction materials, ecological objectives, and time and funding resources.

b) Horizontal (Bank) Stability

Bank stabilization may be needed in natural channels due to flood plain land uses or because newly constructed banks are more prone to erosion than “seasoned” ones. Bank erosion control methods should be selected on the basis of a good understanding of the dominant erosion mechanisms.

Bank stabilization can generally be grouped into three categories: (1) indirect methods, (2) surface armor, and (3) vegetative methods. Indirect methods extend into the stream channel and redirect the flow so that hydraulic forces at the channel boundary are reduced to the non-erosive level. Indirect methods can be classified as dikes (permeable and impermeable) and other flow deflectors such as bendway weirs, Iowa vanes, and stream “barbs”. Armor can be categorized as stone, other self-adjusting armor (sacks, blocks, rubbles, etc.), rigid armor (concrete, soil cement, grouted riprap, etc.) and flexible mattress (gabions, concrete blocks, etc.). Vegetative methods can function as either armor or indirect protection and in some cases can function as both simultaneously. Another category consists of techniques to correct problems associated with geotechnical instabilities.

804.3.3.2 Bank Stability Check

Outer banks of meanders erode, but erosion rates vary greatly from stream to stream and from bend to bend. Observation of the project stream and similar reaches, combined with professional judgment, may be used to determine the need of bank protection, or erosion may be estimated by simple rules of thumb based largely on studies that related bend migration rates to bend geometry. More accurate prediction of the rate of erosion of a given streambank is at or beyond the current state of the art. No standard methods exist, but several recently developed tools are available. None of these have gained universal acceptance and been used in diverse settings, and great caution is advised for their use.

Tools for evaluating bank erosion may be divided into two groups: (1) those that predict erosion primarily due to the action of water on the streambank surface, and (2) those that focus on subsurface geotechnical characteristics.

Among the first group is an index of streambank erodibility based on field observations of emergency spillways (Moore et al. 1994). Erosion is predicted for sites where a power number based on velocity, depth, and bend geometry exceeds an erodibility index calculated from tabulated values of streambank material properties. Also among this group are analytical models such as the one developed by Odgaard (1989), which incorporate sophisticated representations of flow fields, but require input of empirical constants to quantify soil and vegetation properties.

The second group focuses on banks that experience mass failure due to geotechnical processes. Side slopes of deep channels may be high and steep enough to be geotechnically unstable and to fail under the action of gravity. Fluvial processes in such a situation serve primarily to remove blocks of failed material from the bank toe, leading to a resteepped bank profile and a new cycle of failure. Osman and Thorne (1988) presented a procedure relating bank geometry to stability for a specific set of soil conditions. If banks of proposed design channel are to be higher than approximately 10 feet, stability analysis should be conducted. Bank height estimates should include scour along the outside of bends. High, steep banks and banks of soils with high dispersion rates are also susceptible to internal erosion (piping).

a) Assessment of Bank Stability

When channel design requires more quantitative information on soil properties, additional detailed data needs to be collected (Figure 805). Values of cohesion, friction angle, and unit weight of the bank material need to be determined. Because of spatial variability, careful representative sampling and testing are required to correctly characterize the average physical properties of individual layers or to determine a bulk average representation for an entire bank.

Care must also be exercised to characterize soil properties not only at the time of measurement but also for the “worst case” conditions at which failure is expected to occur (Thorne et al. 1981). Unit weight, cohesion, and friction angle vary with moisture content. Typically, it is not possible to directly measure bank materials under worst-case conditions, due to the hazardous nature of unstable sites under such conditions. A qualified geotechnical or soil mechanics engineer should be retained to estimate these strength parameters.

Quantitative analysis of bank instabilities is considered in terms of force and resistance. The shear strength of the bank material provides the resistance of the boundary to erosion by gravity. Shear strength consists of cohesive strength and frictional strength. For the case of a planar failure of unit length, the Coulomb equation can be used:

$$S_r = c + (N - \mu) \tan \phi \quad (833)$$

Where,

- S_r = shear strength, in lb/ft²;
- c = cohesion, in lb/ft²;
- N = normal stress, in lb/ft²;
- μ = pore pressure, in lb/ft²; and
- ϕ = friction angle, in degrees.

Also:

$$N = W \cos \theta$$

Where,

- W = weight of the failure block, lb/ft², and
- θ = angle of the failure plane, in degrees.

The gravitational force acting on the bank is:

$$S_a = w \sin \theta \quad (834)$$

Factors that decrease the erosional resistance (S_r), such as excess pore pressure from saturation and the development of vertical tension cracks, tend to increase bank instabilities. Similarly, increases in bank height (due to channel incision) and bank angle (due to undercutting) tend to increase the chance of bank failure by increasing the gravitational force component. In contrast, vegetated banks generally are drier and provide improved bank drainage, which enhances bank stability. Plant roots provide tensile strength to the soil resulting in reinforced earth that is more capable of resisting mass failure, at least to the depth of roots (Yang 1996).

Channel widening is frequently caused by increases in bank height beyond the critical conditions of the bank material. Simon and Hupp (1992) illustrate that there is a positive

correlation between the amount of bed level lowering by degradation and the amount of channel widening. The adjustment of channel width by mass-wasting processes represents an important mechanism of channel adjustment and energy dissipation in alluvial streams. Channel widening can occur at rates spanning several orders of magnitude, up to hundreds of feet per year (Simon 1994).

Present and future bank stability may be analyzed using the following procedure:

- Determine the current channel geometry and shear strength of the channel banks
- Estimate the future channel geometries and model worst-case pore pressure conditions and average shear strength characteristics

For fine-grained soils, cohesion and friction angle data can be obtained from standard laboratory testing (triaxial shear or unconfined compression tests) or by in situ tests. For coarse-grained, cohesionless soils, estimates of friction angles can be easily obtained from reference manuals. With these data and estimates of future bed elevations, relative bank stability can be assessed using bank stability charts.

b) Bank Stability Charts

To produce bank stability charts, a stability number (N_s) representing a simplification of the bank (slope) stability equations is used. The stability number is a function of the bank-material friction angle (ϕ) and the bank angle (i) and is obtained from a stability chart such as the one developed by Chen (1975) (Figure 806) or from Lohnes and Handy (1968):

$$N_s = (4 \sin i \cos \phi) / [1 - \cos(i - \phi)] \quad (835)$$

The critical bank height H_c , for a given shear strength and bank geometry is then calculated (Carson and Kirkby, 1972):

$$H_c = N_s (c / \gamma) \quad (836)$$

where c = cohesion, in lb/ft^2 , and γ = bulk unit weight of soil in lb/ft^3 .

These equations are solved for a range of bank angles using average or ambient soil moisture conditions to produce the upper line "Ambient field conditions, unsaturated". Critical bank height for worst-case conditions (saturated banks and rapid decline in river stage) are obtained by assuming that ϕ and the frictional component of shear strength goes to 0.0 (Lutton 1974) and by using a saturated bulk unit weight. These results are represented by the lower line, "saturated conditions" (Figure 807).

The frequency of bank failure for the three stability classes (unstable, at-risk, and stable) is subjective and is based primarily on empirical field data (Figure 807). An unstable channel bank can be expected to fail at least annually and possibly after each major stormflow in which the channel banks are saturated, if there is at least one major stormflow in a given year. At-risk conditions translate to a bank failure every 2 to 5 years, if there is a major flow event to saturate the banks and to erode toe material. Stable banks by definition do not fail by mass wasting processes. However, channel banks on the outside of meander bends may experience erosion of the bank toe, resulting in over-steepening of the bank profile and eventually in bank caving.

Generalizations about critical bank heights (H_c) and angles can be made, if the variability in cohesive strengths is known. Five categories of mean cohesive strength of channel banks are presented in Figure 808. Critical bank heights above the mean low-water level and saturated conditions were used to develop the figure because bank failures typically occur during or after the recession of peak flows. The result is a nomograph giving critical bank heights for a range of bank angles and cohesive strengths that can be used to estimate stable bank configurations for worst-case conditions, such as saturation during rapid decline in river stage. For example, a saturated bank at an angle of 55 degrees and a cohesive strength of approximately 1.75 lb/ft² would be unstable when bank heights exceed approximately 10 feet.

804.3.3.3 Local Instability

Local instability refers to erosion and deposition processes that are not a watershed-wide disequilibrium condition (i.e., system-wide instability). The most common form of local instability is probably bank erosion along the concave bank in a meander bend. Local instability may also occur in isolated locations as a result of channel constriction, flow obstructions (ice, debris, structures, etc.), or geotechnical instability. Local instability can also be a part of system instability. In these situations, the local instability problems will probably be worsened by the system instability, and maybe only a system-wide treatment plan will be effective.

Care should be exercised if only local treatments on isolated sites are implemented. If the upstream reach is in equilibrium and the downstream reach is out of balance, it may indicate a system-wide problem. The instability may continue moving upstream unless the cause of the system-wide instability is removed or channel stabilization at and downstream of the site is established.

Local channel instabilities often are a result of redirection of flow caused by debris, structures, or the approach angle from upstream. When flows are moderate or high, obstructions often produce vortices and secondary-flow cells that exert more impacts on channel boundaries, causing local bed scour, erosion of bank toes, and ultimately bank failures. While acceleration of the flow and scour occurs through the constriction, a backwater condition upstream usually results from constrictions of the channel cross section caused by debris accumulation or a bridge.

804.3.3.4 System-Wide Instability

Various factors can disturb the equilibrium of a stream system. Once this occurs, the stream will attempt to reestablish equilibrium by adjusting system variables. These adjustments generally appear as aggradation, degradation, or changes in planform characteristics (meander wavelength, sinuosity, etc.). Depending on the magnitude of the change and the basin characteristics (bed and bank materials, hydrology, geologic or manmade controls, sediment sources, etc.), these adjustments can spread to the entire watershed and even into neighboring systems, which is why this type of disruption of the equilibrium condition is referred to as system instability. If system instability is occurring or expected to occur, the designer should address these problems before any localized bank stabilization or instream habitat development is considered.

804.3.4 DATA REQUIREMENTS

1. General

The primary purpose of this section is to identify data needs for the geomorphic and hydraulic analyses of natural channel systems. Although large volumes of data relative to the morphologic

and hydraulic characteristics of streams have been collected, much of this data is not readily available or applicable to natural channels in Washoe County. Therefore, data collection, which is a prerequisite to any natural channel system analysis, can be a significant portion of a given study. In order to minimize the resource requirement in data collection, a checklist is provided to serve as both a guide for data gathering and as an outline of basic considerations for impact analysis of historical and/or proposed development activities on the natural channel system.

2. Checklist

The type of data needed for qualitative and quantitative alluvial analyses and the relative importance of each data type, are listed in Table 807. Data designated as “primary” are basic data required for any geomorphic, hydraulic, and environmental study of a natural channel. Whenever possible, these data should be directly collected from the field. Other data designated as “secondary” are also useful in an analysis of a natural channel, but are considered a secondary requirement. It must be noted that certain types of data, including hydrologic, hydraulic, channel geometry, and hydrographic, are dynamic in nature and a function of past and present conditions. Therefore, collected data should be validated against present natural channel system conditions to determine their suitability for use.

804.3.5 DESIGN PROCEDURE

1. Determine channel forming discharge
2. Select upstream supply reach and obtain the following information:
 - a. Channel geometry
 - b. Channel slope
 - c. Channel resistance (n)
 - d. Sediment size distribution (A geotechnical analysis shall be conducted to determine the sediment size distribution.)
3. Obtain the same set of data as in Step 2 for the channel reach under consideration
4. Calculate the hydraulic conditions based on the channel forming discharge
5. After determining a sediment transport equation is applicable, the sediment supply from the upstream channel can be computed (such as, using Equation 804 or other appropriate methods). The calculated sediment supply is per unit width. The total sediment transport rate is obtained by multiplying the rate per unit width by the top width of the natural channel.
6. Determine the equilibrium slope for the channel reach under consideration with the sediment supply rate determined in Step 5. This usually requires a trial and error procedure by which a given slope is chosen to calculate the flow conditions and from the calculated flow conditions, the sediment transport is calculated. When the calculated transport rate is equal to the supply rate, the slope used for the calculation is the equilibrium slope.
7. Based on the hydraulic conditions at equilibrium slope, estimate the largest particle size moving for armoring control check. Also, check the applicability of the equations used for the calculation by comparing hydraulic parameters with the range of parameters for the equations.
8. Check whether the channel will be degraded or aggraded during the major design (100-year) storm event.
9. Check bank stability. For bank height less than 10 ft, a simple qualitative assessment (such as maximum allowable side slopes for certain types of channel materials) may be adequate. For bank heights equal to or greater than 10 ft, a quantitative analysis as presented in Section 804.3.3.2 is recommended.

10. If stable conditions can not be achieved without improvements, design improvements and/or develop stabilization plan to achieve stable conditions, such as, drop structures for vertical stability and bioengineering techniques for bank stabilization.

804.4 NATURAL CHANNEL STABILIZATION

804.4.1 INTRODUCTION

When flow velocities exceed the allowable velocity limitation of channel materials, the channel system will experience erosion and stability problems. Traditionally, the “hard lined” channel stabilization techniques (i.e., riprap, gabion, concrete, etc.) have been frequently used by design engineers due to the many advantages they provide, such as, adequate protection against erosion and scour. While the “hard lined” stabilization measures can provide adequate protection against channel erosion and scour in most cases, often, they are not desired due to the aesthetics and environmental impacts created by them. There are many instances where “bioengineered” channel stabilization measures can be safely utilized in place of “hard lined” measures. However, it should be noted that bioengineering stabilization measures are not appropriate for all instances, especially in highly erosive velocity situations in urban environments. “Bioengineered” measures have been most successfully used in natural settings or as part of comprehensive stream restoration projects to stabilize erosion/scour problem areas by providing means to speed up the natural healing and re-vegetation process. For successful application of “bioengineered” stabilization measures, it is important to understand and deal with the causes of the channel stability problems rather than just treating the visible problem areas. Without fixing the sources of the problem, it is likely that the bioengineering measures will fail and channel stability problems will continue to occur.

The interim and final conditions of the “bioengineered” protection measures’ maintenance requirements should be clearly identified and followed in order to minimize failure of the protection. Depending on the type of vegetation protections used and other site-specific soils and hydraulic conditions, it may be necessary to provide additional “temporary” erosion protection measures while the new vegetations get established. In addition, hydraulic capacity of the channel final design conditions should be evaluated to ensure that adjoining properties would not be adversely impacted. Unlike the “hard lined” protections, the area protected by bioengineered measures will continually change its position and shape like the natural channel as a result of hydraulic forces acting on the channel bed and banks.

There are many soil bioengineering systems, and selection of the appropriate system or systems is critical to successful design. Reference documents should be consulted to ensure that the principles of soil bioengineering are understood and applied. The NRCS Engineering Field Handbook, Part 650 [Chapter 16, Streambank and Shoreline Protection (USDA-NRCS 1996) and Chapter 18, Soil Bioengineering for Upland Slope Protection and Erosion Reduction (USDA-NRCS 1992)] offers background and guidelines for application of this technology. Bentrup and Hoag (1998) provide a guide for streambank stabilization techniques in the arid and semi-arid Great Basin and Intermountain West. Eubanks and Meadows (2002) provide a more general guide for streambank and lakeshore stabilization.

804.4.2 CHANNEL STABILIZATION TECHNIQUES

There are many techniques that are being used for stream stabilization. They can be divided into instream practices and streambank stabilization techniques. Examples of instream practices are: boulder clusters; weirs or sills; fish passages; log/brush/rock shelters; lunger structures; migration barriers; tree cover; wing deflectors; and grade control measures. Streambank stabilization techniques include, but are not limited to: bank shaping and planting; branch packing; brush mattresses; coconut fiber roll; dormant post plantings; joint plantings; live cribwalls; live stakes; live fascines; log,

rootwad, and boulder revetments; riprap; stone toe protection; tree revetments; vegetated gabions; and vegetated geogrids. Table 808 summarizes the applications of a selection of available streambank stabilization techniques.

These and other techniques have specific ranges of applicability. The use of any single technique, without consideration of system functions and values, may not be effective. Stabilization techniques are most effective when included as an integral part of a restoration design plan. Typically a combination of techniques is needed. For example, a toe might be stabilized using a tree revetment, with live stakes and live posts installed on the bank behind it. In another situation, a coconut log or live fascine could be used at the toe, with a brush mattress installed above to cover the bank.

The following section provides a brief description for three selected techniques: brush mattresses, joint plantings and vegetated geogrids. For a more general guide on these and other streambank and lakeshore stabilization techniques, refer to Eubanks and Meadows (2002).

804.4.2.1 Brush Mattresses

Brush mattresses are a combination of live stakes, live fascines, and branch cuttings installed to cover and physically protect streambanks and eventually to sprout and establish numerous individual plants.

Brush mattresses can be applied to:

- Provide an immediate protective cover over the streambank
- Capture sediment during flood flows
- Provide opportunities for rooting of the cuttings over the streambank
- Rapidly restore riparian vegetation and streamside habitat

Brush mattresses perform well on steep fast-flowing streams. Toe protection is required where toe scour is anticipated. They are limited to the slope above base flow levels and should not be used on slopes experiencing mass movement or other slope instability.

804.4.2.2 Joint Plantings

Joint planting involves tamping live stakes into joints or openings between rock that has previously been installed on a slope or while rock is being placed on the slope face. Joint plantings disguise riprap and may provide habitat.

Joint Planting can be applied to:

- Places where there is a lack of desired vegetative cover on the face of existing or required rock riprap
- Quickly establish riparian vegetation
- Provide a living mat upon which the rock riprap rests and prevent washout of fines from the underlying soil base by developing root systems

Joint plantings have few limitations and can be installed from base flow levels to top of slope, if live stakes are installed to reach groundwater. Their survival rates range from 30 to 50 percent, which is low due to damage to the cambium or lack of soil/stake interface (Eubanks and Meadows, 2002). They should be used with other soil bioengineering systems and

vegetative plantings to stabilize the upper bank and ensure a regenerative source of streambank vegetation.

804.4.2.3 Vegetated Geogrids

Vegetated geogrids are alternating layers of live branch cuttings and compacted soil with natural or synthetic geotextile materials wrapped around each soil lift to rebuild and vegetate eroded streambanks.

Vegetated geogrids can be applied to:

- Rapidly establish riparian vegetation
- Restore outside bends where erosion is a problem
- Capture sediment to further stabilize the streambank

Vegetated geogrids require a stable foundation and can be installed on a steep (1:1 or steeper) and high slope and have a high initial tolerance of flow velocity.

804.5 FLOOD PLAIN MANAGEMENT OF NATURAL CHANNELS

Some general design considerations and evaluation techniques for natural channels are as follows:

1. The channel and overbank areas shall have adequate capacity for the major storm runoff.
2. Natural channel segments which have a calculated flow velocity greater than the allowable flow velocity determined herein shall be analyzed for erosion potential. Additional erosion protection may be required.
3. The water surface profiles shall be defined so that the flood plain can be delineated.
4. Filling of the flood plain fringe may reduce valuable storage capacity and may increase downstream runoff peaks.
5. Roughness factors which are representative of unmaintained conditions shall be used for the analysis of water surface profiles.
6. Erosion Control structures, such as drop structure or check dams may be required to control flow velocities for both the minor storm and major storm events.
7. A general plan and profile (i.e., HEC-RAS output) of the flood plain shall be prepared which includes appropriate allowances for known future bridges or culverts that will increase the water surface profile and cause the flood plain to be larger.
8. The engineer shall verify, through stable channel (normal depth) calculations, the suitability of the flood plain to contain the flows. If this analysis demonstrates erosion outside of the designated flow path (easement and/or ROW), an analysis of the equilibrium slope and degradation or aggradation depths is required. It may also require bank protection to prevent channel migration outside of the flood plain.

With many natural channels, erosion control structures may need to be constructed at regular intervals to decrease the thalweg slope and to minimize erosion. However, these channels should be left in as near a natural state as possible. For that reason, extensive modifications should not be pursued unless they are found to be necessary to avoid excessive erosion with substantial deposition downstream.

The usual rules of freeboard depth, curvature, and other rules which are applicable to artificial channels do not apply for natural channels. Developments along natural channels shall be elevated in accordance with the regulations for flood plain management purposes. There are significant advantages to a designer incorporating into his planning the overtopping of the channel and localized flooding of adjacent areas which remain undeveloped for the purpose of being inundated during the major runoff peak.

If a natural channel is to be maintained or encroached upon for a development, then the applicant shall meet with the Jurisdictional Entity (if applicable) to discuss the concept and to obtain the requirements for planning and design analysis and documentation.

805 IMPROVED CHANNEL DESIGN

805.1 GENERAL REQUIREMENTS

For the purposes of this section, improved channels are broken down into the following categories:

Swale:	$Q_{100} < 5\text{cfs}$
Minor Improved Channel:	$5\text{ cfs} \leq Q_{100} < 100\text{ cfs}$
Major Improved Channel:	$Q_{100} \geq 100\text{ cfs}$

The design standards presented in this section are the minimum standards by which channel design shall be completed within the Washoe County area. A return period less than 100 years may be acceptable for some limited cases such as where minor flows are present or for improvements in already built-out areas, and will require prior approval. The channel designer is reminded that the ultimate responsibility for a safe channel design lies solely with the engineer responsible for the design. Thus, the execution of this responsibility may require additional analysis and stricter standards than are presented in this section. In addition, the Jurisdictional Entity may require additional design analysis to be performed to verify the suitability of the proposed design for the location under consideration.

805.1.1 SWALE

Requirements for swales are not covered herein. Consult the Jurisdictional entity for requirements specific to each jurisdiction.

805.1.2 MINOR IMPROVED CHANNEL

This category covers the majority of improved channels within the Washoe County area. Due to the large variation in site conditions and other considerations crucial to proper design, it is impractical to provide criteria which cover every situation. Therefore, it is the responsibility of the design engineer to ensure a stable channel with minimum maintenance requirements, in addition to other elements of proper design. At a minimum, minor improved channels must meet the following requirements [Note: the City of Reno requires that constructed public drainage facilities with design flows of 60 cfs or less be piped.]:

Freeboard:	For subcritical flow, the minimum freeboard shall be determined by Eqn. 849, but shall not be less than 6 in. For supercritical flow, the minimum freeboard shall be determined by Eqn. 856, but shall not be less than 6 in.
------------	--

Maintenance Access: In general, all minor improved channels must be maintainable with equipment readily available to the local Jurisdictional Entities, including provisions for access both alongside of and into the channel as appropriate. The requirement for maintenance access will be decided on a case by case basis. Section 807.1 which covers major improved channels should also be used as guidance for minor improved channels. While it may be appropriate for very short runs of swale to be maintained by hand (i.e., a laborer with a shovel and a wheelbarrow), this is not appropriate for longer reaches, for reaches where anticipated maintenance frequency is high, or where hand maintenance will not otherwise be appropriate.

Requirements for minor improved channels are the same as for major improved channels, with the exception of the freeboard requirement (specified above) and except as approved by the Jurisdictional Entity based on geometry, flow rates, etc. associated with minor improved channels.

805.1.3 MAJOR IMPROVED CHANNEL

The rest of Section 805 pertains to requirements for major improved channels. Figure 809 shows typical design sections which may be used in the Washoe County area. The selection of a channel section and lining is generally dependent on physical and economic channel restrictions (i.e., value of developable land), the slope of the proposed channel alignment, the rate of flow to be conveyed by the channel, and the comparative costs of the lining materials. The channel sections and linings discussed herein provide a wide range of options from which an appropriate channel may be selected. Specific hydraulic design standards which are applicable to all improved channels (i.e. transition, freeboard, etc.) are presented in Section 806.

Within Section 805 six types of improved channels will be discussed: unlined channels, grass-lined channels, wetland bottom channels, riprap-lined channels, concrete-lined channels, and channels with other types of channel linings.

805.2 PERMANENT UNLINED CHANNELS

Permanent unlined channels are improved channels which are constructed to the shape of vegetation-lined channels but are not revegetated. The cost of construction of these channels is relatively low for areas with flat slopes and where the design flow rates and velocities are small. The designer must adequately address potential erosion problem areas (i.e., bends, transitions, structures) as well as the overall stability of the unlined channel and the effect that possible future natural revegetation may have on the channel hydraulics.

The stability of the channel shall be analyzed as if the channel was a natural channel using the design standards in Section 804. In addition, the layout, alignment, and cross-section of the channel shall be designed as if the channel was to be revegetated using the design standards in Section 805.3.

805.3 NON-REINFORCED GRASS-LINED CHANNELS

Grass-lined channels may be considered to be the most desirable artificial channels from an aesthetics viewpoint. The channel storage, lower velocities, and the sociological benefits create significant advantages over other types of channels. The designer must give full consideration to potential sediment deposition and scour, as well as flow hydraulics for which calculations shall be submitted for review to the Jurisdictional Entity.

The satisfactory performance of a grass-lined channel depends on constructing the channel with the proper shape and preparing the area in a manner to provide conditions favorable to vegetative growth. Between the time of seeding and the actual establishment of the grass, the channel is unprotected and subject to considerable damage unless special protection is provided. Channels subject to constant or

prolonged flows require special supplemental treatment, such as grade control structures, stone centers, or subsurface drainage capable of carrying such flows. After establishment, the protective vegetative cover must be maintained.

The Jurisdictional Entity may require a maintenance agreement and/or bond to cover maintenance of grass-lined channels. In addition, the Jurisdictional Entity may not allow the use of grass-lined channels where insufficient precipitation exists to maintain the grass lining without irrigation.

805.3.1 DESIGN PARAMETERS

805.3.1.1 Longitudinal Channel Slopes

Grass-lined channel slopes are dictated by maximum permissible velocity requirements. Where the natural topography is steeper than desirable, drop structures (Section 1200) shall be utilized to maintain design velocities.

805.3.1.2 Roughness Coefficient

The Manning's roughness coefficient used in the channel design shall be obtained from Figure 810 assuming a mature channel (i.e., substantial vegetation with minimal maintenance).

805.3.1.3 Low-Flow Channels

Low flows and sometimes base flows from urban areas must be given specific attention. Waterways which are normally dry prior to urbanization will often have a continuous base flow after urbanization because of lawn irrigation return flow, both overland and from a groundwater in-flow. Since continuous flow over grass will destroy a grass stand and may cause the channel profile to degrade, low-flow channels are required on all urban grass-lined channels. Though concrete lined low-flow channels may prevent erosion, silting, and excessive plant growth, and be preferred based on ease of maintenance, they are generally considered unsightly by the public, and do not promote a natural environment or support vegetative growth, promote good water quality, provide cover, or habitat and are not flexible. Therefore they will be allowed only with prior agency approval for areas where, in the Jurisdictional Entity's opinion, the benefits of concrete outweigh considerations based on aesthetics, water quality, animal habitat, plant growth and diversity, and recreation. Other types of low-flow channels are acceptable if they are properly designed. Low-flow channels may not be practical on larger major drainageways, or in channels located on sandy soils where other design approaches may be the more appropriate choice.

Low-flow channels are required within channels with a 100-year flow greater than or equal to 1,000 cfs, or where the bottom width of the channel is greater than or equal to 20 feet. The following required dimensions are based on the wheel base of common maintenance equipment and the assumption that at some point it will be desirable for equipment to span the low-flow channel and move along its length for maintenance activities. Low-flow channels shall meet the following requirements:

1. Shall be armored
2. Shall be sized to accommodate perennial flow with no freeboard, or be constructed 4 feet wide x 1 foot deep - whichever is greater. Where riprap is used, a swale of these dimensions may be used, lined with stones no less than 6" in diameter.

3. For riprap only: Shall meander across the bottom of the channel or the width of the flood plain
 - a. Meanders shall have irregular pattern
 - b. Meanders shall be setback 3 feet from either channel bank or sideslope to allow for maintenance access.
 - c. The wavelength of the meander shall on average be no greater than 2 times the channel bottom width.
 - d. Shall be designed such that flows hydrate the adjacent channel bottom to support the grass lining

805.3.1.4 **Bottom Width**

The minimum bottom width shall be 8 feet (including the low flow channel if required) without prior agency approval.

805.3.1.5 **Flow Depth**

Typically, the maximum design depth of flow (outside the low-flow channel area) for the major storm flood peak should not exceed 5 feet for a 100-year flow of 1,500 cfs or less. For greater flows excessive depths should be avoided to minimize high velocities and for public safety considerations.

805.3.1.6 **Side Slopes**

Side slopes shall not be designed steeper than 3 horizontal to 1 vertical.

805.3.1.7 **Grass Lining**

The grass lining for channels shall consist of a grass species (or other similar vegetation) which is adapted to the Washoe County climate and will flourish under artificial irrigation. Flowering plants, (i.e., Honeysuckle) and weeds shall not be used for grass-lined channels. Grass lining shall only be considered stable where it can be shown that adequate moisture is present to sustain the plant growth, either through artificial irrigation or through the selection of plants adapted to the arid climate of the region. Where grass-lined side slopes is not appropriate for the site condition, another design approach may be taken for the side slopes and the channel shall be shown to be stable for the design condition.

805.3.1.8 **Establishing Vegetation**

Channel vegetation is established usually by seeding. In the more critical sections of some channels it may be desirable to provide immediate protection by transplanting a complete sod cover.

Jute, plastic, or paper mesh and straw or hay mulch may be used to protect the entire width and side slopes of a waterway until the vegetation becomes established. All seeding, planting and sodding should conform to local agronomic recommendations.

805.3.2 CHANNEL BEND PROTECTION

The potential for erosion increases along the outside bank of a channel bend due to the acceleration of flow velocities on the outside part of the bend. Thus, it is often necessary to provide erosion protection in natural or grass-lined channels which otherwise would not need protection.

In erosion resistant soils, no extra protection is required along bends where the radius is greater than 2 times the top width of the water surface during the 100-year flow, but in no case less than 100 feet. Channel bends with radii smaller than stated above require riprap protection where the 100-year flow is greater than 20 cfs. If riprap protection is used the minimum radius is 1.2 times the top width and in no case less than 50 feet. For channels with bottom width of less than 10 feet, the Jurisdictional Entity will determine minimum requirements. Riprap protection should extend downstream from the end of the bend to a distance that is equal to the length of the bend measured along the channel centerline.

805.4 WETLAND BOTTOM CHANNELS

Under certain circumstances, such as when the Jurisdictional Entities are interested in features other than strictly conveyance and stability, or when existing wetland areas are affected or natural channels are modified, the Corps of Engineers Section 404 permitting process may mandate the use of channels with wetland vegetation in their bottoms. In other cases, a wetland bottom channel may better suit individual site needs if used to mitigate wetland damages elsewhere or if used to enhance urban runoff quality, provide habitat, improve aesthetics and promote growth of vegetation. These types of channels are in essence grass-lined channels, with the exception that wetland type vegetation is encouraged to grow in their bottom. The easiest way to achieve this is to eliminate the concrete-lined low-flow channel from the drainageway's bottom and to limit its longitudinal slope so that low flows have low velocities.

There are potential benefits associated with a wetland bottom channel. These include habitat for aquatic, terrestrial, and avian wildlife and possible water quality enhancement as the base flows move through the marshy vegetation.

The downside of this practice is that the channel bottom is "boggy" and can become overgrown. As a result, it is impossible to mow the bottom grasses and very difficult to control the density of vegetation. This more abundant bottom vegetation traps sediments, thereby reducing channel flood-carrying capacity as the bottom fills with sediments. Eventually, depending on the sediment loads being carried by the flows, the channel bottom will have to be dredged to restore its flood-carrying capacity. Wetland bottom channels can provide habitat for mosquito breeding, and because the abundant vegetation can dislodge during a flood, an increased potential exists for blockage of drainageway crossing structures.

Since wetland bottoms will decrease flow conveyance and accelerate channel bottom aggradation, the channel cross-section needs to be enlarged for flood conveyance. As a result, more right-of-way will be needed than required for a well groomed grass-lined channel. In areas where urbanization has already taken place, wetland bottom channels may not be feasible. Where right-of-way is limited, mitigating flood damages should take precedence over other considerations during project design. In cases when existing wetlands are eliminated or reduced, off-site wetland mitigation may be required by the Corps of Engineers' 404 Permit. The design of channels with wetland bottoms can be a complicated, iterative process. In order to simplify the design procedure for this Manual, assumptions have been made concerning how the flow depth in a channel interacts with the wetland vegetation and affects the channel roughness and the rate of sediment deposition on the bottom.

805.4.1 DESIGN PARAMETERS

805.4.1.1 Longitudinal Channel Slope

The longitudinal channel slope will be set so the maximum permissible velocity criteria provided in Table 803 is not violated. To prevent channel degradation, the channel slope should be determined assuming there is no wetland vegetation on the bottom (i.e., “New Channel”). In addition to the velocity requirements, the Froude number for the new channel condition shall be less than 0.7.

805.4.1.2 Roughness Coefficients

The channel must be designed for two flow roughness conditions. As previously mentioned, a Manning’s roughness coefficient assuming there is no growth in the channel bottom is used to set the channel slope. This is referred to as the New Channel condition. The Mature Channel condition assumes that wetland vegetation in the channel bottom has been established. The required channel depth including freeboard is determined assuming Mature Channel conditions.

A composite Manning’s roughness coefficient should be used for the New Channel condition design and the Mature Channel condition design. The composite Manning’s roughness coefficient is determined by the following equation (Chow, 1959):

$$n_c = \frac{(n_o^2 P_o + n_w^2 P_w)^{0.5}}{(P_o + P_w)} \quad (837)$$

where,

- n_c = Manning’s roughness coefficient for the composite channel
- n_o = Manning’s roughness coefficient for areas above the wetland area
- n_w = Manning’s roughness coefficient for the wetland area
- P_o = Wetted perimeter of channel cross-section above the wetland area (ft)
- P_w = Wetted perimeter of the wetland channel bottom (ft)

For grass-lined areas above the wetland area, use a Manning’s roughness coefficient, n_o , of 0.035. Manning’s roughness coefficients for the wetland area (n_w) are supplied by Figure 814. Consideration of future maintenance and presence of woody growth must also be considered and n values chosen values accordingly.

805.4.1.3 Low-Flow Channel

Low-flow channels shall be used when the 100-year flow exceeds 1,000 cfs or where the bottom width of the channel is greater than or equal to 20 feet. The design of the low-flow channel is according to Section 805.3.1.3.

805.4.1.4 Bottom Width

The minimum bottom width will be designed according to Section 805.3.1.4.

805.4.1.5 Flow Depth

The maximum flow depth shall be designed according to Section 805.3.1.5.

805.4.1.6 Side Slopes

The side slopes shall be designed according to Section 805.3.1.6.

805.4.1.7 Grass Lining

The side slopes shall be grass-lined according to Section 805.3.1.7. Where grass-lined side slopes is not appropriate for the site condition, another design approach may be taken and the channel shall be shown to be stable for the design condition.

805.4.2 CHANNEL BEND PROTECTION

Channel bends shall be designed according to the criteria in Section 805.3.2.

805.4.3 CHANNEL CROSSINGS

Whenever a wetland bottom channel is crossed by a road, railroad or a trail requiring a culvert or a bridge, consideration shall be given to both low flows and high flows, as well as erosion on the upstream and downstream slopes of the crossing and overall stability. The crossing shall be designed to be stable for the full range of design flow conditions as well as for poorly bearing soils that are anticipated in such an environment.

805.4.4 LIFE EXPECTANCY

Wetland vegetation bottom channels are expected to fill with sediment over time. This occurs because the bottom vegetation traps some of the sediments carried by the flow. The life expectancy of such a channel will depend primarily on the land use of the tributary watershed and could range anywhere from 20 to 40 years before major channel dredging is needed. However, life expectancy can be dramatically reduced, to as little as two to five years, if land erosion in the tributary watershed is not controlled. Therefore, land erosion practices need to be strictly controlled during new construction within the watershed and all facilities need to be built to minimize soil erosion in the watershed to maintain a reasonable economic life of a wetland bottom channel.

805.5 RIPRAP-LINED CHANNELS

Riprap-lined channels are defined as channels in which riprap is used for lining of the channel banks and the channel bottom, as required. Riprap used for erosion protection at transitions and bends is also considered as a riprap-lined channel and those portions shall be designed in accordance with the riprap-lined channel and transition design standards. The design standards presented in this section are the minimum hydraulic design parameters and limitations to minimize riprap movement in a fully lined channel as well as to minimize erosion of the channel section for channels with only bank lining.

Riprap has proven to be an effective means to deter erosion along channel banks, in channel beds, upstream and downstream from hydraulic structures, at bends, bridges, and in other areas where erosive tendencies exist. Riprap is a popular choice for erosion protection because the initial installation costs are often less than alternative methods for preventing erosion. However, the designer needs to bear in mind that there are additional costs associated with riprap erosion protection since riprap installations require frequent inspection and maintenance.

Channel linings constructed from loose riprap or grouted riprap to control channel erosion have been found to be cost effective for many applications. Situations for which riprap lining might be appropriate are: 1) where major flow, such as the 100-year flood are found to produce channel

velocities in excess of allowable non-eroding values (typically 5 ft/sec); 2) where channel side slopes must be steeper than 3:1; 3) for low-flow channels, 4) where a rigid lining is undesirable, and 5) where rapid changes in channel geometry occur such as channel bends and transitions. Design criteria applicable to these situations are presented in the following sections.

805.5.1 DESIGN PARAMETERS

805.5.1.1 Longitudinal Channel Slope

Riprap-lined channel slopes are dictated by the maximum permissible velocity requirements (Table 803). Where topography is steeper than desirable, drop structures (Section 1200) shall be utilized to maintain design velocities.

805.5.1.2 Roughness Coefficients

Resistance coefficients (Manning's n) for loose riprap surfaces can be estimated using the following form of Strickler's equation:

$$n = K \left[D_{90}(\text{min})^{1/6} \right] \quad (838)$$

where

- $D_{90}(\text{min})$ = size of which 90 percent of sample is finer by weight, from minimum or lower limit curve of gradation specification (ft),
- $K = 0.036$ average of all flume data,
- $K = 0.034$ for velocity and stone size calculation, and
- $= 0.038$ for capacity and freeboard calculation.

The K values represent the upper and lower bounds of laboratory data determined for bottom riprap. Resistance data from a large laboratory channel having an irregular riprap surface similar to riprap placed underwater resulted in a 15% increase in Manning's n above the dry placement values given above. These Manning n values represent only the grain resistance of the riprap surface.

805.5.1.3 Low-Flow Channel

The design of a low-flow channel is discussed in Section 805.3.1.3.

805.5.1.4 Bottom Width

The minimum channel bottom width for a riprap-lined channel should be designed according to Section 805.3.1.4.

805.5.1.5 Flow Depth

As preliminary criteria, the design depth of flow for the major storm runoff flow should not exceed 7.0 feet in areas of the channel cross-section outside the low-flow channel.

805.5.1.6 Side Slopes

Due to stability, safety, and maintenance considerations, riprap-lined side slopes shall be 2 horizontal to 1 vertical or flatter.

805.5.1.7 Toe Protection

Where only the channel sides are to be lined, the riprap blanket shall extend a minimum of 3 feet below the proposed channel bed, and the thickness of the blanket below the proposed channel bed should be increased to a minimum of 3 times d_{50} to accommodate possible channel scour during floods. Alternately, the configuration of riprap below the channel bed may be based on one of the methods outlined in section 805.5.7. If the velocity exceeds the velocity requirements of the soil comprising the channel bottom, a scour analysis should be performed to determine if the toe requires additional protection.

805.5.1.8 Beginning and End of Riprap-Lined Channel

At the upstream and downstream termination of a riprap lining, the thickness should be increased 50 percent for at least 3 feet to prevent undercutting.

805.5.2 TYPES OF RIPRAP

805.5.2.1 Loose Riprap

Loose riprap, or simply riprap, refers to a protective blanket of large loose stones, which are usually placed by machine to achieve a desired configuration. A typical cross-section for riprap-lined channels is shown in Figure 815. The term loose riprap has been introduced to differentiate loose stones from grouted riprap. Loose riprap should be placed on adequate bedding.

Many factors govern the size of the rock necessary to resist the hydraulic forces tending to move the riprap. For the riprap itself, this includes the size and weight of the individual rock, the shape of stones, the gradation of the particles, the blanket thickness, the type of bedding under the riprap, and the slope of the riprap layer. Hydraulic factors affecting riprap include the velocity, current direction, eddy action and waves.

Experience has shown that riprap failures generally result from undersized individual rocks in the maximum size range, improper gradation of the rock which reduces the interlocking of individual particles, and improper bedding for the riprap which allows leaching of channel particles through the riprap blanket.

805.5.2.2 Grouted Riprap

The use of grouted riprap is discouraged and subject to approval by the Jurisdictional Entities. Grouted riprap provides a relatively impervious channel lining which is less subject to vandalism than loose riprap. Grouted riprap is particularly useful for lining low-flow channels and steep banks.

As with loose riprap, grouted riprap should be placed on adequate bedding. The grout material shall be in accordance with the latest edition of the Standard Specifications for Public Works Construction. Grouted riprap shall be constructed in accordance with the latest edition of the Standard Specifications for Public Works Construction and shall penetrate either the full depth of the riprap layer or at least 2 feet where the riprap layer is thicker than 2 feet. Grout penetration may be accomplished by rodding, vibrating, or pumping of the grout into the riprap voids. Weep holes should be provided in the blanket to provide rapid relief of any hydrostatic pressure behind the blanket. A typical grouted riprap section is depicted in Figure 816.

805.5.3 RIPRAP MATERIAL

Riprap is classified in the Washoe County area by mass as Classes A (500 lb), B (375 lb), C (Light), and D (facing) and by size as Classes 900, 550/700, 300/400, and 150. Riprap grading and quality shall meet all requirements and be in accordance with the latest edition of the Standard Specifications for Public Works Construction. For drainage purposes, it is desirable to have a range of sizes intermixed together to provide an even and interlocking protective layer.

Rock used for loose riprap, grouted riprap, or wire enclosed riprap should be hard, durable, angular in shape, and free from cracks, overburden, shale and organic matter. Neither breadth nor thickness of a single stone should be less than 1/3 its length and rounded stone should be avoided. Rocks having a minimum specific gravity of 2.50 are required.

805.5.4 BEDDING REQUIREMENTS

Long term stability of riprap erosion protection is strongly influenced by proper bedding conditions. A large percentage of all riprap failures are directly attributable to bedding failures. Properly designed bedding provides a buffer of intermediate sized material between the channel bed and the riprap to prevent leaching of channel particles through the voids in the riprap. Two types of bedding are in common use, granular bedding and filter fabric.

805.5.4.1 Granular Bedding

Two methods for establishing gradation requirements for granular bedding are described in this section. The first, a single layer of granular bedding, is adequate for most ordinary riprap, grouted riprap or wire encased riprap applications. The second is a detailed design procedure developed by Terzaghi, which is referred to as the T-V (Terzaghi-Vicksburg) design (Murphy, 1971). The T-V filter criteria established an optimum bedding gradation for a specific channel soil. The latter requires channel soil information, including a gradation curve, while the single layer bedding may be used whether or not soil information is available.

The gradation of a single layer bedding specification was based on the T-V filter criteria and the assumption that a bedding which will protect an underlying noncohesive soil with a mean grain size of 0.0018 in. (0.045 mm) will protect anything finer. Since the T-V filter criteria provides some latitude in establishing bedding gradation, it was possible to make the single layer bedding specification generally conform with the Standard Specifications for Public Works Construction, Class C Backfill (Section 200.03.04).

A single 12-inch layer of Class C backfill bedding can be used except at drop structures. At drop structures, filter fabric must be added below the 12-inch layer of granular bedding.

The specifications for the T-V reverse filter method relate the gradation of the protective layer (filter) to that of the bed material (base) by the following inequalities:

$$D_{15}(\text{filter}) < 5d_{85}(\text{base}) \tag{839}$$

$$4d_{15}(\text{base})D_{15}(\text{filter}) < 20d_{15}(\text{base}) \tag{840}$$

$$D_{50}(\text{filter}) < 25d_{50}(\text{base}) \tag{841}$$

Where, the capital "D" refers to the filter grain size and the lower case "d" to the base grain size. The subscripts refer to the percent by weight which is finer than the grain size denoted by either "D" or "d". For example, 15 percent of the filter material is finer than D_{15} (filter) and 85 percent of the base material is finer than d_{85} (base).

When the T-V method is used, the thickness of the resulting layer of granular bedding may be reduced to six inches. However, if a gradation analysis of the existing soils shows that more than 50 percent of the soil is smaller than the No. 40 sieve size (> 50 percent passing No. 40 sieve by weight), then a two-layer granular bedding shall be used. The design of the bedding layer closest to the existing soils shall be based on the existing soil gradation. The design of the upper bedding layer shall be based on the gradation of the lower bedding layer. The thickness of each of the two layers shall be at least 4 inches.

805.5.4.2 Filter Fabrics

Filter fabric shall be designed in accordance with manufacturer's specifications. Filter fabric is not a complete substitute for granular bedding. Filter fabric provides filtering action only perpendicular to the fabric and has only a single equivalent pore opening between the channel bed and the riprap. Filter fabric has a relatively smooth surface which provides less resistance to stone movement. As a result, it is recommended that the use of filter fabric in place of granular bedding be restricted to slopes no steeper than 2.5 H:1V. A 6-inch layer of fine aggregate (Standard Specifications for Public Works Construction 200.01.03) may be placed on top of the filter fabric to act as a cushion when placing the riprap.

Tears in the fabric greatly reduce its effectiveness so that direct dumping of riprap on the filter fabric is not allowed and due care must be exercised during construction. Nonetheless, filter fabric has proven to be an adequate replacement for granular bedding in many instances. Filter fabric provides adequate bedding for channel linings along uniform mild sloping channels where leaching forces are primarily perpendicular to the fabric.

At drop structures and sloped channel drops, where seepage forces may run parallel with the fabric and cause piping along the bottom surface of the fabric, special care is required in the use of filter fabric. Seepage parallel with the fabric may be reduced by folding the edge of the fabric vertically downward about 2 feet (similar to a cutoff wall) at 12 foot intervals along the installation, particularly at the entrance and exit of the channel reach. Filter fabric has to be lapped a minimum of 12 inches at roll edges with upstream fabric being placed on top of downstream fabric at the lap.

Fine silt and clay have been found to clog the openings in filter fabric. This prevents free drainage which increases failure potential due to uplift. For this reason, a granular bedding is often more appropriate for fine silt and clay channel beds.

805.5.5 ROCK SIZING

Riprap lining requirements for a stable channel lining are based on the following relationship which resulted from model studies by Smith and Murray (Smith, 1965) and application to design criteria (Stevens, 1981):

$$V = 3(d_{50})^{0.5} S_S - 1 / S^{0.17} \tag{842}$$

where,

V = Mean channel velocity, in ft/sec (10 ft/sec maximum for riprap-lined channel)
 S = Longitudinal channel slope, in ft/ft

S_s = Specific gravity of rock (Minimum $S_s = 2.50$)
 d_{50} = Rock size, in ft, for which 50 percent of the riprap by weight is finer.

Equation (842) was developed using laboratory data. Other procedures for design of riprap have been developed by a number of agencies, such as Federal Highway Administration (Searcy, 1967; Normann, 1975), USACE (1970), USBR (Peterka, 1958), California Department of Transportation (1970), American Society of Civil Engineers (Vanoni, 1975), (Simons and Sentruk, 1992). Blodgett (1986) evaluated these procedures and presented a tentative design relationship based on field data:

$$D_{50} = 0.010V^{2.44} \quad (843)$$

Where,

V = Mean Channel Velocity, in ft/sec
 d_{50} = Rock size, in ft, for which 50 percent of the riprap by weight is finer.

Equation (843) is helpful for estimating the size of riprap needed and generally yields sizes larger than those determined by using Equation (842). However, use of a design method based on tractive stress considering bank slope is preferred for final design.

The basic premise underlying riprap design method based on tractive force is that the flow-induced tractive force should not exceed the permissible or critical shear stress of the riprap. Assuming a specific gravity of 2.50, the following equation can be used to determine d_{50} of the riprap by the tractive stress method:

$$d_{50} = 14.2F_s Y_{\max} \frac{S_e}{K_1} \quad (844)$$

Where,

F_s = Stability factor:
 = 1.0 - 1.2, for straight or mildly curving reach
 = 1.2 - 1.4, for moderate bend curvature with minor impact from floating debris
 = 1.4 - 1.6, for sharp bend with significant impact from floating debris and waves
 = 1.6 - 2.0, for rapidly varying flow with significant uncertainty in design
 Y_{\max} = maximum channel depth, in ft
 S_e = average energy slope, in ft/ft
 K_1 = bank angle modification factor
 = $[1 - (\sin^2 \Phi / \sin^2 \theta)]^{0.5}$
 Φ = bank angle with horizontal
 θ = riprap material angle of repose (see Figure 818A)

805.5.6 LINING DIMENSIONS

Rock lined side slopes steeper than 2H:1V are considered unacceptable because of stability, safety, and maintenance considerations. Proper bedding is required both along the side slopes and the channel bottom for a stable lining. The riprap blanket thickness should adhere to the following rules:

1. The thickness should be at least two times d_{50} .
2. The thickness should not be less than the diameter of the upper limit d_{100} stone.
3. The thickness determined by either (1) or (2) above should be increased by 50 percent in all sections when the riprap is placed under water in water deeper than 3 feet to provide for uncertainties associated with this type of placement.

4. An increase in thickness of 6 to 12 inches, accompanied by an appropriate increase in stone sizes, should be provided where riprap revetment will be subject to attack by floating debris or by waves from boat wakes or wind.

The blanket should extend up the side slopes to the freeboard requirements in this Manual. At the upstream and downstream termination of a riprap lining, the thickness should be increased 50 percent for at least 3 feet to prevent undercutting.

805.5.7 EDGE PROTECTION

The edges of riprap revetments are subject to additional hydraulic forces by being adjacent to other materials. The top, toe, and flanks require special treatment to prevent undermining (Section 805.5.1).

The flanks of the revetment should be designed as illustrated in Figure 818B. If the riprap ends at a bridge abutment or other secure point, special bank protection at the riprap perimeter is not needed. If the riprap does not terminate at a stable point, the cross-section shown as Method B in Figure 818B should be considered for the downstream edge as well.

Undermining of the revetment toe is one of the primary mechanisms of riprap failure. Figures 818 C - F illustrate toe protection alternatives. It is preferable to design the toe as illustrated in Figure 818D (Method B from Figure 818C). The toe material is placed in a toe trench along the entire length of the riprap blanket. See the alternate design in 818D. Care must be taken during the placement of the stone to ensure that the toe material does not mound and form a low dike. A low dike along the toe could result in flow concentration along the revetment face which could stress the revetment to failure. In addition, care must be exercised to ensure that the channel design capacity is not impaired by placement of too much riprap in a toe mound.

The size of the toe trench or alternate stone toe is controlled by the anticipated scour depth along the revetment. The depth of scour can be estimated from the scour analysis. As scour occurs, the stone in the toe will launch into the eroded area as illustrated in Figure 818E. Observation of rock toe performance indicates that the riprap will launch to a final slope of approximately 2H:1V. The volume of rock required for the toe must be equal to or exceed one and one-half times the volume of rock required to extend the riprap blanket (at its design thickness and on a slope of 2H:1V) to the anticipated depth of scour.

805.5.8 CHANNEL BEND PROTECTION

The potential for erosion increases along the outside bank of a channel bend due to the acceleration of flow velocities on the outside part of the bend. Thus, it is often necessary to provide erosion protection at this location in natural or vegetation-lined channels which otherwise would not need protection. In addition, greater than normal riprap thickness and sometimes larger sizes are needed at bends in riprap-lined channels.

The riprap protection should be placed along the outside of the bank, and should extend from the entrance of the bend to a point downstream from the bend exit, a distance equal to the length of the bend measured at the channel centerline. Additionally, the riprap blanket should extend up the side slope at least 2 feet above the design water surface, or per the freeboard requirements in this section.

For bends in natural or vegetation-lined channels, the standard straight channel riprap lining criteria (Section 806) shall be used. For bends in riprap-lined channels where the bend radius is less than two times the water surface top width for major storm flows, increase the riprap thickness by 50 percent from the designed riprap thickness.

805.5.9 TRANSITIONS PROTECTION

Scour potential is amplified by turbulent eddies in the vicinity of rapid changes in channel geometry such as transitions and bridges. For these locations, the riprap lining thickness shall be increased by 50 percent from the designed riprap thickness.

Protection should extend upstream from the transition entrance at least 5 feet and extend downstream from the transition exit at least 10 feet. See Section 806 for further discussion on transitions.

805.5.10 CONCRETE CUTOFF WALLS

Transverse concrete cutoff walls may be required by the Jurisdictional Entity for riprap-lined channels where a resulting failure of the riprap lining could seriously affect the health and safety of the public. The designer shall consult with the Jurisdictional Entity prior to design of riprap-lined channels to determine if concrete cutoff walls are required as well as their sizing and spacing, if required.

805.5.11 RIPRAP-LINED CHANNELS ON STEEP SLOPES

805.5.11.1 Introduction

Achieving channel stability on steep slopes usually requires some type of channel lining. The only exception is a channel constructed in durable bedrock.

On mild slopes, the water velocity is slow enough and the depth of flow is large enough (relative to the riprap size) that a reasonable estimate of the resistance to flow can be made. On steep channels, the riprap size required to stabilize the channel is on the same order of magnitude or greater than the flow depth, which invalidates the Manning's relation. Since the resistance to flow is now unknown, an estimate of the velocity needed for the design of the riprap cannot be accurately estimated.

A graphically based methodology was developed for the U.S. Department of Interior, Office of Surface Mining Reclamation and Enforcement (Simons, 1989) to design riprap-lined channels on steep slopes (supercritical flow). This methodology was based on a study by Bruthurst (1979) that analyzed the hydraulics of mountain rivers where roughness elements are on the same order of magnitude as the depth of flow. Using the resistance equation developed by Bruthurst, the velocity can be estimated for a given riprap size. The velocity is then used to predict the stability of the riprap.

This procedure shall be used for all riprap-lined channels whose depth of flow is equal to or less than d_{50} as computed initially using Equations 842, 843 or 844.

805.5.11.2 Rock Size

Five sets of design curves (Figures 819 through 823) have been developed from Bruthurst's relationship to simplify riprap design for steep channels. The design curves were developed for channels with 2 to 1 side slopes and bottom widths of 0 ft, 6 ft, 10 ft, 14 ft, and 20 ft. The curves were terminated at the point where flow velocity exceeded 15 ft/sec. A median rock diameter could be determined that would be stable at higher flows and velocities; however, rock durability at velocities greater than 15 ft/sec becomes of greater concern.

For a given flow, channel slope, and channel width, Figures 819 through 823 provide the median riprap size. When the channel slope is not provided by one of the design curves, linear interpolation is used to determine the riprap size. This is done by extending a

horizontal line at the given flow through the curves with slopes bracketing the design slope. A curve at the design slope is then estimated by visual interpolation. The design D_{50} size is then chosen at the point that the flow intercepts the estimated design curve. Linear interpolation can also be used to estimate the D_{50} size for bottom widths other than those supplied in the figures.

For practical engineering purposes, the D_{50} size specified for the design shall be rounded up to the nearest 0.25-foot increment.

805.5.11.3 Riprap Gradation for Steep Slopes

Lack of proper riprap gradation is one of the most common causes of riprap failure. With the proper rock gradation, the voids formed by larger stones are filled with smaller sizes in an interlocking fashion that prevents jets of water from contacting the underlying soil and ultimately eroding the soil supporting the riprap layer.

Ratios used to determine the D_{10} , D_{20} , and D_{max} rock sizes from the D_{50} rock size determined in the previous section are shown below and in Table 809. It is important to establish a smooth gradation from the largest to the smallest sizes to prevent large voids between rocks.

805.5.11.4 Riprap Thickness for Steep Slopes

For riprap linings on steep slopes, a thickness of 1.25 times D_{50} is required. The maximum resistance to the erosive forces of flowing water occurs when all rock is contained within the riprap layer thickness. Oversize rocks that protrude above the riprap layer reduce channel capacity and reduce riprap stability.

805.5.11.5 Riprap Placement on Steep Slopes

Improper placement is another major cause of failure in riprap-lined channels. To prevent segregation of rock sizes, riprap should never be placed by dropping it down the slope in a chute or pushing it down with a bulldozer. Rock can be dumped directly from trucks from the top of the embankment, and draglines with orange peel buckets, backhoes, and other power equipment can also be used to place riprap with a minimum of handwork.

805.5.11.6 Freeboard

Figures 819 through 823 also provide the depth of flow for a given flow, channel slope, and channel dimensions. The required freeboard is determined by Equation 856. The velocity can be estimated by dividing the flow rate by the area of flow.

805.5.11.7 Bedding Requirements on Steep Slopes

Either a granular bedding material or filter fabric may be used on steep slopes according to the requirements specified in Section 805.5.4.

805.6 CONCRETE-LINED CHANNELS

Concrete-lined channels are defined as rectangular or trapezoidal channels in which reinforced concrete is used to line the channel banks and bottom. The cost of concrete channels generally can be more economical than other lining types in an urban environment due to their greater flow-carrying capacity resulting in less land area requirements.

805.6.1 DESIGN PARAMETERS

The following sections present the recommended design parameters for concrete-lined channels. The design parameters presented do not relieve the designer of performing the appropriate engineering analysis.

805.6.1.1 Longitudinal Channel Slope

The maximum slope of concrete-lined channels is determined by the maximum permissible velocity requirements (Table 803). Concrete-lined channels have the ability to accommodate supercritical flow conditions and thus can be constructed to almost any naturally occurring slope.

805.6.1.2 Roughness Coefficients

The Manning's roughness coefficient for concrete-lined channels is as shown in Table 802. For concrete-lined channels with subcritical flow, check the Froude number using a roughness coefficient of 0.011.

805.6.1.3 Low-Flow Channel

The bottom of the concrete channel shall not be constructed with a defined low-flow channel but shall be adequately sloped to confine the nuisance flows to the middle or one side of the channel.

805.6.1.4 Bottom Width

There are no bottom width requirements for concrete-lined channels.

805.6.1.5 Flow Depth

There are no flow depth requirements for concrete-lined channels.

805.6.1.6 Side Slopes

Concrete-lined channels may have side slopes that are vertical or flatter.

805.6.2 CONCRETE LINING SECTION

805.6.2.1 Thickness

All concrete lining shall have a minimum thickness of 6 inches for flow velocities less than 30 ft/sec and a minimum thickness of 7 inches for flow velocities of 30 ft/sec and greater.

805.6.2.2 Concrete Joints

The following design standards, found to work in similar conditions, are suggested for use in the Washoe County area. Alternatives will be considered on a case by case basis.

- a. Channels shall be continuously reinforced without transverse joints. Expansion / contraction joints (without continuous reinforcement) shall only be installed where the new concrete lining is connected to a rigid structure or to an existing concrete lining

which is not continuously reinforced. The design of the expansion joint shall be coordinated with the Jurisdictional Entity.

- b. Longitudinal joints, where required, shall be constructed on the sidewalls at least one foot vertically above the channel invert.
- c. All joints shall be designed to prevent differential movement.
- d. Construction joints are required for all cold joints and where the lining thickness changes. Reinforcement shall be continuous through the joint and the concrete lining shall be thickened at the joint.

805.6.2.3 Concrete Finish

The surface of the concrete lining shall be provided with a wood float finish, unless the design requires additional finishing treatment. Excessive working or wetting of the finish shall be avoided if additional finishing is required.

805.6.2.4 Concrete Curing

It is suggested that concrete-lined channels be cured by the application of a liquid membrane-forming curing compound (white pigmented) upon completion of the concrete finish. All curing shall be completed in accordance with latest edition of the Standard Specifications.

805.6.2.5 Reinforcement Steel

- a. Steel reinforcement shall be a minimum grade 40 deformed bars. Wire mesh shall not be used because of difficulties in ensuring proper installation.
- b. Ratio of longitudinal steel area to the concrete cross-sectional area shall be greater than 0.004 but not less than a No. 4 rebar at 12-inch spacing. The longitudinal steel shall be placed on top of the transverse steel.
- c. The ratio of transverse steel area to the concrete cross-sectional area shall be greater than 0.0025, but not less than a No. 4 rebar placed at 12-inch spacing.
- d. Reinforcing steel shall be placed near the center of the section with a minimum clear cover of three inches adjacent to the earth.
- e. Additional steel shall be added as needed. If a retaining wall structure is used, the structure must be designed by a registered structural engineer with structural design calculations submitted to the Jurisdictional Entity for review.

805.6.2.6 Earthwork

At a minimum, the following areas shall be compacted to at least 90 percent of maximum density as determined by ASTM 1557 (Modified Proctor). The following additional requirements may be required by the geotechnical report.

- a. The 12 inches of subgrade immediately beneath concrete lining (both channel bottom and side slopes)
- b. Top 12 inches of maintenance road
- c. Top 12 inches of earth surface within 10 feet of concrete channel lip
- d. All fill material

805.6.2.7 Bedding

A geotechnical report shall be submitted to the Jurisdictional Entity which addresses the required bedding necessary for the specific concrete section under consideration.

805.6.2.8 Underdrain and Weepholes

The necessity for longitudinal underdrains and weepholes shall be addressed in a geotechnical report submitted to the Jurisdictional Entity for the specific concrete channel section under consideration.

805.6.2.9 Concrete Cutoffs

A transverse concrete cutoff shall be installed at the beginning and end of the concrete-lined section of channel and at a maximum spacing of 90 feet. The concrete cutoffs shall extend a minimum of three feet below the bottom of the concrete slab and across the entire width of the channel lining. Longitudinal cutoffs at top lining shall be considered to ensure integrity of the concrete lining.

If the channel is continuously reinforced without transverse joints, then a concrete cutoff is required to be incorporated into the expansion/contraction joint.

805.6.3 SPECIAL CONSIDERATION FOR SUPERCRITICAL FLOW

Supercritical flow in an open channel in an urbanized area creates hazards which the designer must take into consideration. Careful attention must be taken to ensure against excessive waves which may extend down the entire length of the channel from only minor obstructions. Imperfections at joints may rapidly cause a deterioration of the joints, in which case a complete failure of the channel can readily occur. In addition, high velocity flow entering cracks or joints creates an uplift force by the conversion of velocity head to pressure head which can damage the channel lining.

Generally, there should not be a drastic reduction in cross-section shape and diligent care should be taken to minimize the change in wetted area of the cross-section at bridges and culverts. Bridges and other structures crossing the channel must be anchored satisfactorily to withstand the full dynamic load which might be imposed upon the structure in the event of major debris plugging.

The concrete lining must be protected from hydrostatic uplift forces which are often created by a high water table or momentary inflow behind the lining from localized flooding. Generally an underdrain will be required under and/or adjacent to the lining.

The underdrain must be designed to be free draining. With supercritical flows, minor downstream obstructions do not create any backwater effect. Backwater computation methods are applicable for computing the water-surface profile or the energy gradient in channels having a supercritical flow; however, the computations must proceed in a downstream direction. The designer must take care to ensure against the possibility of unanticipated hydraulic jumps forming in the channel.

805.7 OTHER CHANNEL LININGS

Other channel linings include all channel linings which are not discussed in the previous sections. These include composite-lined channels which are channels in which two or more different lining materials are used (i.e. riprap bottom with concrete side slope lining). They also include gabions, articulated concrete blocks, soil cement linings, synthetic fabric and geotextile linings, reinforced soil linings and floodwalls (vertical walls constructed on both sides of an existing flood plain). The wide

range of composite combinations and other lining types does not allow a discussion of all potential linings in this Manual. For those linings, supporting documentation will be required to support the use of the desired lining. A guideline of some of the items which must be addressed in the supporting documentation is as follows:

- a. Structural integrity of the proposed lining
- b. Interfacing between different linings
- c. The maximum velocity under which the lining will remain stable
- d. Potential erosion and scour problems
- e. Access for operations and maintenance
- f. Long term durability of the product under the extreme meteorological and soil conditions in the Washoe County area
- g. Ease of repair of damaged section
- h. Past case history (if available) of the lining system in other arid areas
- i. Potential groundwater mitigation issues (i.e. weepholes, underdrains, etc.)
- j. Vandalism and off-road vehicles
- k. Loss of intimate contact between lining and soil due to vegetation regrowth

These linings will be allowed on a case by case basis. Because of the potential significant unknown problems with these lining types, concurrence with the Jurisdictional Entity on the design items to be addressed as well as the final design will be required. The Jurisdictional Entity reserves the right to reject the proposed lining system in the interests of operation, maintenance, and protecting the public safety.

The following section provides information on articulated concrete blocks and gabions.

805.7.1 ARTICULATED CONCRETE BLOCKS

Articulated Concrete Block (ACB) systems with vegetative linings offer an ecologically sound alternative to other conventional erosion control practices. It provides both the protection of hard armor and the environmental benefits of a soft, permeable cover.

ACB systems consist of a geotextile underlayment, an ACB matrix (interlocking or cable-tied), stone or soil aperture backfill, and (in most applications) vegetative cover.

805.7.1.1 Geotextile

The geotextile underlayment (filter fabric) is an integral part of the ACB system as it provides the system with: bidirectional water permeability, soil retention, ACB/fabric static friction, and sufficient open area for the establishment of vegetative root growth through the fabric and into the underlying soils. Typically, woven mono-filaments with 10% to 25% open area and a weight of 5 to 8 oz/yd can be used. Non-woven 6 to 8 oz/yd filter fabric can also be used if the soils have low to no fine particle content. The selection of an appropriate fabric should be based on the soil gradation and hydraulic conductivity.

805.7.1.2 ACB Systems General

ACBs provide a trafficable, pedestrian friendly surface without significant upward projections and open void areas. Maintenance is also enhanced. Revetment stability of riprap type systems is typically good to excellent when the proper size and shape stone is selected. However, riprap typically requires four to twenty times the mass to achieve the hydraulic stability of an ACB system. Stone riprap generally does not provide the low roughness coefficients of an ACB system.

The designer should use the manufacturer's literature for the selection of appropriate block sizes for a given hydraulic condition. Manufacturers of ACBs have a responsibility to test their products and to develop design criteria based on the results from these tests. Since ACBs vary in shape and performance from one proprietary system to the next, each system will have unique design criteria.

The concrete blocks shall meet manufacturer's criteria for a minimum unit weight, flow velocities and shear stress and shall be sited appropriately based on site conditions. Typical values for these requirements are as follows:

- Minimum unit weight: 32 lb/ft² to 45 lb/ft²
- Shall withstand a minimum flow velocity of 7 ft/sec or higher
- Shall withstand a minimum shear stress of 4 lb/ft²

805.7.1.3 ACB Backfill Material

The open areas within and around the individual blocks in an ACB system provide sub-structural hydrostatic pressure relief, engineered surface roughness, water permeability for groundwater recharge, and open area for backfill material and the establishment of vegetation throughout the revetment lining. The amount of open area within the revetment can be designed to accommodate the specific project needs and can range from 2% to 30% of the total revetment surface area.

The open areas can be backfilled with crushed stone (for underwater applications and areas where vegetation is not desired) or with soil (conducive to the establishment of vegetation). If vegetation is not desired, low percent open area ACBs (<5%) can be used without the need for stone backfill.

Typically, sharp-edged (crushed) stone with sizes ranging from 1/2" to 3/4" is used and the stone backfill is installed flush with the ACB top surfaces.

Above the normal water level is typically where soil backfill is used and vegetation is established. The backfill soil should be indigenous to the area and nutrient rich. The open areas should be completely filled and, in most cases, be overfilled to 20% to 35% of the ACB height to give allowance for backfill soil settlement. For an example, if the ACB is 4" high, the system should be backfilled to a thickness of 1" to 1-1/2" above the top of the blocks. Heavy equipment should not be used in the backfilling process since it may damage the ACBs. Typically, lightweight and rubber-tired equipment such as skidsters and landscape tractors can be used.

805.7.1.4 Vegetating the ACB System

There are a variety of methods that can be used to establish vegetation on ACB revetment systems. Hydro-seeding is typically the most common method. General procedures involved in vegetating the ACB system are as follows:

a) **Qualify backfill soil**

The ideal ACB soil backfill material is loamy type. The texture of backfill soil can be improved by mixing in organic matter such as soil conditioner, composted manure, peat moss, or compost prior to installation. Most grasses thrive in a particular range of pH values. If needed, the pH of the soil can be adjusted by blending lime into acid soil or by blending sulfur or gypsum into alkaline soil before installing the soil backfill in the ACB open areas.

1. **Select the type of vegetation**

In general, a grass or plant species that is deep rooting and resistant to heavy rain and drought should be selected. The goal is to establish deep root penetration through the underlying filter fabric and into the sub-grade and maintain hearty, thick and green top foliage.

2. **Select a starter fertilizer**

A proper starter fertilizer should be selected based on local experience and soil conditions.

3. **Select the method of application**

By far one of the best methods for applying seed grasses and plants is hydraulically seeding and mulching (also known as “hydro-seeding”). Hydro-seeding is a method of seed planting whereby water, seed, fertilizer and wood fiber mulch (or recycled paper) are blended in a tank and then discharged onto the prescribed area through a hose and nozzle.

Another technique is to mix seeds with the soil backfill material prior to installation.

b) **Artificial Irrigation**

Regular watering should be considered for at least the first growing season. The first 4 weeks are the most critical, as the plant has not yet established a root system that can feed on the moisture and nutrients trapped in the underlying soil. Periodic mowing and fertilizing may also be needed.

805.7.2 GABIONS

Gabions refer to rocks confined by a wire basket/mesh as a single unit. The wire mesh enclosed rock units are also known as gabion baskets and/or mattresses. One of the advantages of wire enclosed rocks is that it provides an alternative in situations where available rock sizes are too small for ordinary riprap. Another advantage is the versatility that results from the regular geometric shapes of wire enclosed rocks. The rectangular blocks and mats can be formed into almost any shape that can be made with concrete. The durability of wire enclosed rock is generally limited by the service life of the galvanized confining wire which, under normal conditions in the Washoe County area, is approximately 35 years. In applications where the gabions are subjected to frequent wet conditions, the life span diminishes to approximately 15 years (Myers, 2000). Water carrying silt, sand or gravel can reduce the service life of the wire. Also, water that rolls or otherwise moves cobbles and large stones breaks the wire with a hammer and/or anvil action and significantly shortens the life of the wire. The wire has been found to be susceptible to corrosion by various chemical agents and is particularly affected by high sulfate soils. If corrosive agents are known to exist in the water or soil, a

plastic coated wire should be specified. The design engineer should verify site specific conditions and coordinate with a qualified manufacturer to properly specify gabion wire. See ASTM A-974 and ASTM A-975.

Gabions are not maintenance free and must be regularly inspected to determine whether the wire remains in good condition. If breaks are found while still relatively small, they may be patched by weaving new strands of wire into the wire cage. Installations of wire-enclosed rocks have been found to attract vandalism. Flat mattress surfaces seem to be particularly susceptible to having wires cut and stones removed. It is recommended that, where possible, mattress surfaces be buried to avoid vandalism. Gabions should be inspected at least once a year under the best circumstances and may require inspection every three months in vandalism prone areas in conjunction with a regular maintenance program. They should also be inspected after major storm events. Under high flow velocity conditions, mattresses on sloping surfaces must be securely anchored to the subsoil.

805.7.2.1 Materials

a) Rock and Wire Enclosure

Rock filler for the wire baskets should meet the rock property requirements for ordinary riprap. Rock sizes and basket characteristics should meet ASTM A-974 and ASTM A-975. The minimum rock size (d_0) shall be greater than the size of the gabion opening. The maximum rock size (d_{100}) shall be less than the gabion thickness.

b) Bedding

Long term stability of gabion (and riprap) erosion protection is dependent on proper bedding. Refer to Section 805.5.4 for granular bedding or filter fabrics bedding design.

805.7.2.2 Design Considerations

The geometric properties of gabions permit their placement in areas where ordinary riprap is either difficult or impractical. Proper design and installation is important to successful operation and long-term performance. Twisted wire mesh has been found to be more tolerant to settlement than welded wire mesh (See ASTM A-975).

Figure 824 shows a typical configuration for a gabion slope mattress channel lining. The long side of the gabion basket should be aligned parallel with the channel for applications on banks steeper than 2:1. Channel linings should be tied to the channel banks with gabion counterforts (thickened gabion sections that extend into the channel bank) at the upstream edge of the lining. Counterfort spacing shall be per manufacturer's recommendations. Mattresses and flat gabions on channel side slopes need to be tied to the banks. The ties should be metal stakes no less than 4 feet in length (sandy soils warrant longer lengths). These should be located at the inside corners of basket diaphragms along an upslope (highest) basket wall, so that the metal stakes are an integral part of the basket. The exact spacing of the stakes depends upon the specific configuration of the baskets; however, the suggested minimum spacing is to place stakes every 6 feet along and down the slope for 2:1 slopes or steeper.

806 ADDITIONAL HYDRAULIC DESIGN STANDARDS

Presented in this section are the hydraulic design standards for design of improved channels. The standards included herein are those standards which are the same for all improved channels. Standards which are specific to a lining type are included in the discussion for the specific lining under consideration. For the design of channel confluences, information can be found in publications

such as the U. S. Army Corps of Engineers' Hydraulic Design of Flood Control Channels (EM-1110-2-1601).

806.1 SUBCRITICAL FLOW DESIGN STANDARDS

The following design standards are to be used when the design runoff in the channel is flowing in a subcritical condition ($Fr < 0.86$). For all channels with ($Fr > 0.86$), the design standards as stated in Section 802.2 are to be observed.

806.1.1 TRANSITIONS

For the purposes of this Manual, subcritical transitions occur when transitioning one subcritical channel section to another subcritical channel section (expansion or contraction) or when a subcritical channel section is steepened to create a supercritical flow condition downstream (i.e., sloping spillway entrance). Several typical subcritical transition sections are presented in Figures 825 and 826. The warped transition section, although most efficient, should only be used in extreme cases where minimum loss of energy is required since the section is very difficult and costly to construct. Conversely, the square-ended transition should only be used when either a straight-line transition or a cylinder-quadrant transition cannot be used due to topographic constraints or utility conflicts.

806.1.1.1 Transition Energy Loss

The energy loss created by a contracting section may be calculated using the following equation:

$$H_t = K_{tc} \left[\left(V_2^2 / 2g \right) - \left(V_1^2 / 2g \right) \right] \tag{845}$$

where,

- H_t = Energy loss (ft)
- K_{tc} = Transition coefficient-contraction
- V_1 = Upstream velocity (ft/sec)
- V_2 = Downstream velocity (f/sec)
- g = Acceleration of gravity (32.2 ft/sec²)

K_{tc} values for the typical transition sections are presented in Figure 826.

Similarly, the energy loss created by an expanding transition section may be calculated using the following equation:

$$H_t = K_{te} \left[\left(V_1^2 / 2g \right) - \left(V_2^2 / 2g \right) \right] \tag{846}$$

where,

- H_t = Energy loss (ft)
- K_{te} = Transition coefficient-expansion
- V_1 = Upstream velocity (ft/sec)
- V_2 = Downstream velocity (f/sec)
- g = Acceleration of gravity (32.2 ft/sec²)

K_{te} values for the typical transition sections are presented in Figure 826.

The energy loss in a contracting transition for straight-line or warped transitions is allowed to be partially or totally accommodated by sloping the transition channel bottom from the transition entrance to the exit.

806.1.1.2 Transition Length

The length of the transition section should be long enough to keep the streamlines smooth and nearly parallel throughout the expanding (contracting) section. Experimental data and performance of existing structures have to be used to estimate the minimum transition length necessary to maintain the stated flow conditions. Based on this information, the minimum length of the transition section shall be as follows:

$$L_t \geq 0.5L_c(\Delta T_w) \tag{847}$$

where,

L_t = Minimum transition length (ft)

L_c = Length coefficient (dimensionless)

ΔT_w = Difference in the top width of the normal water surface upstream and downstream of the transition (ft)

For an approach flow velocity less than 12 feet per second, $L_c = 4.5$. This represents a 4.5 (length) to 1.0 (width) wall expansion or contraction with the angle of expansion or contraction of 12.5 degrees from the channel centerline. For an approach flow velocity equal to or greater than 12 feet per second, $L_c = 10.0$. This represents a 10.0 (length) to 1.0 (width) expansion or contraction with the angle of expansion or contraction of about 5.75 degrees from the channel centerline.

The transition length equation is not applicable to cylinder-quadrant or square-ended transitions.

806.1.2 SUPERELEVATION IN BENDS

Superelevation in bends is estimated from the following equation:

$$S_e = C(V^2 T_w) / (rg) \tag{848}$$

where,

r = Radius of curvature (ft)

C = Superelevation coefficient (= 0.5 for Subcritical flow)

S_e = Superelevation water surface increase (ft)

T_w = Top width of the design water surface (ft)

V = Mean design velocity (ft/sec)

g = Acceleration of gravity (32.2 ft/sec²)

Within Washoe County superelevation shall be limited to a maximum of 1.0 foot, and the radius of curvature shall conform to the requirements provided in Section 806.2.2.

806.1.3 FREEBOARD

All subcritical channels shall be constructed with a minimum freeboard determined as follows:

$$F_b = 0.5 + V^2 / (2g) \tag{849}$$

where,

- F_b = Freeboard height (ft)
- V = Mean design velocity (ft/sec)
- g = Acceleration of gravity (32.2 ft/sec²)

In no case shall the freeboard be less than 1 foot. All channel linings must extend to the freeboard height plus the increase in water surface elevation due to superelevation.

806.2 SUPERCRITICAL FLOW DESIGN STANDARDS

The following design standards are to be used when the design runoff in the channel is flowing in a supercritical condition or has a Fr > 0.86. Since flow with a Froude number between 0.86 and 1.13 is relatively unstable, channels with a Froude number within this range should be designed as a supercritical channel. Furthermore, all supercritical channels must be designed within the limits as specified in Section 802.2.

806.2.1 SUPERCRITICAL TRANSITIONS

The design of a supercritical flow in a transition requires special attention and is much more complicated than a subcritical transition design due to the potential damaging effects of the oblique hydraulic jump which occurs in the transition. The oblique jump results in cross waves and higher flow depths which can cause severe damage if not properly accounted for in the design. The simpler design analysis is to force a hydraulic jump (supercritical flow to subcritical flow). However, hydraulic jumps must also be carefully designed to assure the jump will remain where the jump is designed to occur. In the Washoe County area, hydraulic jumps shall not be designed to occur in an erodible channel section but only in an energy dissipation or drop structure. The design of these structures is presented in Section 1200 (Additional Hydraulic Structures).

806.2.1.1 Contracting Transitions

Presented in Figure 827 is an example of supercritical contracting transition. As shown in this figure, the upstream flow is contracted from width b_1 to b_3 with a wall diffraction angle of θ . The oblique jump occurs at the points A and B where the diffraction angles start. Wave fronts generated by the oblique jumps on both sides propagate toward the centerline with a wave angle β_1 . Since the flow pattern is symmetric, the centerline acts as if there was a solid wall that causes a subsequent oblique jump and generates a backward wave front toward the wall with another angle β_2 . These continuous oblique jumps result in turbulent fluctuations in the water surface.

To minimize the turbulence, the first two wave fronts are designed to meet at the center and then end at the exit of the contraction. Using the contraction geometry, the length of the transition shall be as follows:

$$L_t = (b_1 - b_3)/(2 \tan \theta) \quad (850)$$

Where,

- L_t = Transition length (ft)
- b_1 = Upstream topwidth of flow (ft)
- b_3 = Downstream topwidth of flow (ft)
- θ = Wall angle as related to the channel centerline (degrees)

Using the continuity principle,

$$b_1/b_3 = (Y_3^{1.5} / Y_1)(F_3 / F_1) \quad (851)$$

where,

Y_1 = Upstream depths of flow (ft);
 Y_3 = Downstream depths of flow (ft);
 F_1 = Upstream Froude number;
 F_3 = Downstream.

Also, by the continuity and momentum principles, the following relationship between the Froude number, wave angle, and wall angle is found to be:

$$\tan \Phi = \frac{\tan \beta_1 \left[\left(1 + 8F_1^2 \sin^2 \beta_1 \right)^{1/2} - 3 \right]}{2 \tan^2 \beta_1 + \left(1 + 8F_1^2 \sin^2 \beta_1 \right)^{1/2} - 1} \quad (852)$$

Where,

β_1 = Initial wave angle (degrees).

Equations 850, 851, and 852 can be used by trial and error to determine the transition length and wall angle. However, Figure 828 is provided to allow a quicker trial and error solution than by using the equations. The procedure to determine the transition length and wall angle between two pre-determined channel sections using Figure 828 is as follows:

- Step 1: Determine the upstream and downstream channel flow conditions including flow depths, velocities, and Froude numbers
- Step 2: If either or both sections are trapezoidal, convert the trapezoidal flow parameters to equivalent rectangular flow parameters by calculating an equivalent flow width equal to the flow area divided by the flow depth. This computed flow width is used for all calculations.
- Step 3: Compute Y_3 / Y_1
- Step 4: Assume a trial wall angle, θ
- Step 5: Using θ and F_1 , read the values of F_2 and Y_2/Y_1 for Section 1 from Figure 828. Then, replacing F_1 with F_2 , read a second F_2 (really F_3) and second Y_2/Y_1 (really Y_3/Y_2) from Figure 828 for Section 2.
- Step 6: Compute the first trial value of Y_3/Y_1 by multiplying the Y_2/Y_1 for Section 1 by the Y_2/Y_1 (really Y_3/Y_2) for Section 2
- Step 7: Compare the first trial Y_3/Y_1 to the actual Y_3/Y_1 (Step 3). If the trial value Y_3 / Y_1 is larger than the actual Y_3/Y_1 , assume a smaller θ and redo Steps 5 through 7. If the trial value Y_3 / Y_1 is smaller than the actual Y_3 / Y_1 , assume a larger θ and redo Steps 5 through 7.
- Step 8: Repeat the trial and error procedure until the computed Y_3 / Y_1 is within 5 percent of the actual Y_3 / Y_1
- Step 9: Compute transition length using Equation 850 and the last assumed value of θ

Figure 828 can also be used to determine the wave angle, β , or may be used with the equations to determine the required downstream depth or width parameter if a certain transition length is designed or required.

To minimize the length of the transition section, Y_3/Y_1 should generally be between 2 and 3. However, F_3 shall not be less than 1.7 for all transition designs. For further discussion on oblique jumps and supercritical contractions, refer to Chow, 1959.

806.2.1.2 Expanding Transitions

The goal of a properly designed expansion transition is to expand the flow boundaries at the same rate as the natural flow expansion. Based on experimental and analytical data results, the minimum length of a supercritical expansion shall be as follows:

$$L_t \geq 1.5(\Delta T_w) Fr_1 \tag{853}$$

Where,

L_t = Minimum transition length (ft);

ΔT_w = Difference in the top width of the normal water surface upstream and downstream of the transition;

Fr_1 = Upstream Froude number.

806.2.2 SUPERELEVATION IN BENDS

Bends in supercritical channels create cross waves and superelevated flow in the bend section as well as further downstream from the bend. In order to minimize these disturbances, the minimum radius of curvature in the bend shall not cause superelevation of the water surface exceeding 2.0 feet. Equation (848) can be modified to determine allowable radius of curvature of a channel for a given superelevation value. In no case shall the radius of curvature be less than 50 feet.

$$r = C(v^2 T_w) / (S_e g) \tag{854}$$

C shall equal 1.0 for all trapezoidal channels and for rectangular channels without transition curves. For rectangular channels with transition curves, C shall equal 0.5.

806.2.3 CIRCULAR TRANSITION CURVES

When a designer desires to reduce the required amount of freeboard and radius of curvature in a rectangular channel, a circular transition curve may be used. The length of the transition curve measured along the channel centerline shall be determined as follows:

$$L_c = 0.32 T_w V / Y^{0.5} \tag{855}$$

where,

L_c = Length of transition curve (ft);

T_w = Top width of design water surface (ft);

V = Mean design velocity (ft/sec);

y = Depth of design flow (ft).

The radius of the transition curves should be twice the radius of the main bend. Transition curves shall be located both upstream and downstream of the main bend.

806.2.4 FREEBOARD

In supercritical channels, adequate channel freeboard above the designed water surface shall be provided and shall not be less than that determined by the following:

$$F_b = 1.0 + 0.025V(d)^{1/3} \tag{856}$$

where,

F_b = Freeboard height (ft);

V = Velocity (ft/sec);

d = Depth of flow (ft).

Freeboard shall be in addition to superelevation, standing waves, and/or other water surface disturbances.

The channel lining side slopes shall be extended, as a minimum, to the freeboard elevation.

806.2.5 SLUG FLOW

Slug flow is a series of shallow-water shock waves which occur in steep supercritical channels. The resulting wave heights may easily overtop channel linings using the typical freeboard requirements presented in this Manual or damage the channel lining. Therefore, all channels in the Washoe County area shall be designed to avoid the occurrence of slug flow. To avoid slug flow when the Froude number is greater than 2.0, the channel slope shall be as follows:

$$S \leq (12/R_e) \tag{857}$$

where,

S = Channel slope (ft/ft) (858)

$R_e = VR/\nu$ = Reynolds Number

V = Mean design velocity (ft/sec)

R = Hydraulic radius (ft)

ν = Kinematic viscosity of water (ft²/sec).

Theoretically, slug flow will not occur with $Fr < 2.0$.

807 CHANNEL APPURTENANCES

Presented in this section are the design standards for appurtenances to improved channels. All channels in the Washoe County area shall be designed to include these appurtenances.

807.1 MAINTENANCE ACCESS ROAD

A maintenance access road shall be provided along the entire length of all improved channels with a minimum passage width of 12 feet. For channels less than 30 feet in top width, one maintenance access shall be provided as part of the channel improvements. For channels greater than 30 feet in top width, the maintenance road shall be located at the bottom of the channel or on both sides at the channel top. Deviations from this are subject to approval by the appropriate jurisdictional entity.

807.2 SAFETY REQUIREMENTS

The following safety requirements are required for concrete-lined channels. Similar safety requirements may be required for all other channels:

- a. Unless otherwise approved by the Jurisdictional Entity, a six-foot high galvanized coated chain link or comparable fence shall be installed to prevent unauthorized access. The fence shall be

located at the edge of the ROW or on the top of the channel lining. Gates, with top latch, shall be placed at major access points or 1,320 foot intervals, whichever is less.

- b. Ladder-type steps shall be installed not more than 1,200 feet apart and shall be staggered on alternating sides of the channel to provide a ladder every 600 feet. The bottom rung shall be placed approximately 12 inches vertically above the channel invert.

807.3 CULVERT OUTLET PROTECTION

If the flow velocity at a culvert or storm sewer outlet exceeds the maximum permissible velocity for the local soil or channel lining, channel protection is required. This protection usually consists of an erosion resistant reach, such as riprap, to provide a stable reach at the outlet in which the exit velocity is reduced to a velocity allowable in the downstream channel.

807.3.1 BASIN CONFIGURATION

The length of the outlet protection (L_a) is determined using the following empirical relationships that were developed for the U.S Environmental Protection Agency (1976):

$$L_a = (1.8Q/D_o^{3/2}) + 7D_{05} \text{ for } TW < D_o / 2 \quad (859)$$

and

$$L_a = (3Q/D_o^{3/2}) + 7D_{05} \text{ for } TW \geq D_o / 2 \quad (860)$$

where,

- D_o = Maximum inside culvert width (ft) or diameter;
- Q = Pipe discharge (cfs);
- TW = Tailwater depth (ft).

Where there is no well defined channel downstream of the apron, the width, W , of the outlet and of the apron (as shown in Figure 829) should be as follows:

$$W = 3D_o + 0.4L_a \text{ for } TW \geq D_o / 2 \quad (861)$$

and

$$W = 3D_o + L_a \text{ for } TW < D_o / 2 \quad (862)$$

The width of the apron at the culvert outlet should be at least 3 times the culvert width.

Where there is a well-defined channel downstream of the apron, the bottom width of the apron should be at least equal to the bottom width of the channel and the lining should extend at least one foot above the tailwater elevation and at least two-thirds of the vertical conduit dimension above the invert.

The side slopes should be 2:1 or flatter, and the bottom grade should be level.

807.3.2 ROCK SIZE

The median stone diameter, d_{50} is determined from the following equation (ASCE, 1975):

$$d_{50} = 0.02Q^{4/3} / (TWD_o^{4/3}) \quad (863)$$

Existing scour holes may be used where flat aprons are impractical. Figure 830 shows a general design of a scour hole. The stone diameter is determined using the following equations:

$$d_{50} = 0.01245Q^{4/3} / (TWD_o^{4/3}) \text{ for } Y = D_o / 2 \quad (864)$$

Also,

$$d_{50} = 0.0082Q^{4/3} / (TWD_o^{4/3}) \text{ for } Y = D_o \quad (865)$$

where Y = Depth of scour hole below culvert invert.

The other riprap requirements are as indicated in the previous sections for channel lining.

807.4 GRADE CONTROL STRUCTURES

807.4.1 INTRODUCTION

With the advent of flood plain management programs, developers and local governments frequently decided to preserve the flood plain. Since urbanization causes more frequent and sustained flows, the low-flow channel becomes more susceptible to erosion even though the overall flood plain may remain stable and able to resist major flood events.

Erosion of the low-flow channel, if left uncontrolled, can cause degradation and destabilization of the entire flood plain. Low flow check structures are designed to provide control points and establish stable bed slopes within the base flow channel. The check structures can be small versions of the drop structures described elsewhere in this section or in many instances simply control sills across the flood plain. Low flow check structures are not appropriate in instances such as completely incised flood plains or very steep channels.

807.4.2 GRADE CONTROL CONCEPTS

In its broadest sense, the term “grade control” can be applied to any human modification in the watershed which provides stability to the streambed. Currently, the common method of establishing grade control is the construction of in-channel grade control structures. There are two types of grade control structures. One type of structure is “Bed Control Structure” which provides a hard point in the streambed that is capable of resisting the erosive forces of the stream. This is similar to locally increasing the size of the bed material. The other type of structure is “Hydraulic Control Structure”, which is designed to reduce the energy slope along the degradational zone to the point that the stream is no longer capable of scouring the bed.

807.4.3 DESIGN CONSIDERATIONS FOR SITING GRADE CONTROL STRUCTURES

Design considerations for siting grade control structures usually include determination of the type, location and spacing of structures along the stream, along with the elevation and dimensions of structures. Other considerations include hydraulic factors, geotechnical factors, flood control impacts, environmental factors, existing structures, local site conditions, downstream channel response, geologic controls, and effects on tributaries.

807.4.3.1 Hydraulic Considerations

Mussetter (1982) suggested that the optimum spacing should be the length of the deposition above the structure which is a function of the deposition slope (Figure 831). Figure 831 also illustrates the recommendations of Johnson and Minaker (1944) that the optimum spacing can be determined by extending a line from the top of the first structure at a slope equal to the maximum equilibrium slope of sediment upstream until it intersects the original streambed.

The hydraulic siting of grade control structures is fairly straightforward and can be determined by:

$$H(S_o - S_f)x \tag{866}$$

Where, H is the amount of drop to be removed from the reach, S_o is the original bed slope, S_f is the final, or equilibrium slope, and x is the length of the reach (Goitom and Zeller, 1989).

The number of structures (N) required for a given reach can then be determined by:

$$N = H/h \tag{867}$$

Where, h is the selected drop height of the structure.

Equation (807) indicates that one of the most important factors when siting grade control structures is the determination of the equilibrium slope (S_f).

807.4.3.2 Geotechnical Considerations

In some cases, the geotechnical stability of the reach may be an important or even the primary factor to consider when siting grade control structures. Traditional bank stabilization measures may not be appropriate in situations where system-wide bank instabilities exist. In these instances, grade control may be more appropriate. Grade control structures can enhance the bank stability of a channel in several ways. Bed control structures indirectly affect the bank stability by stabilizing the bed, thereby stabilizing the length of bankline that may reach an unstable height. Two additional benefits are: (1) a reduction in bank heights due to sediment deposition, and (2) a lowering in velocities and scouring potential due to the creation of a backwater situation.

807.4.3.3 Flood Control Impacts

Channel improvements for flood control and channel stability need to be coordinated. It is important to identify any increased post-project flood potential. Grade control structures are commonly designed to be hydraulically submerged at flows less than bankfull so that the frequency of overbank flooding is not affected. However, if the structure exerts control through a wider range of flows including overbank, then the frequency and duration of overbank flows may be affected. When this is the case, the effects must be quantified and appropriate measures such as acquiring flowage easements or modifying structure plans should be provided.

Another factor that needs to be considered when siting grade control structures is the safe return of overbank flows back into the channel. This is particularly a problem when the flows are out of bank upstream of the structure but still within bank downstream. The resulting head differential can cause damage to the structure as well as severe erosion of the channel banks depending upon where the flow re-enters the channel.

807.4.3.4 Environmental Considerations

The final siting of a grade control structure is often adjusted to minimize adverse environmental impacts. Grade control structures can also provide direct environmental benefits to a stream, such as enhancements in fisheries resources (Cooper and Knight, 1987; Shields et al., 1990). One of the negative environmental impacts of grade control structures is the obstruction of fish passage.

The environmental effects of the project must be an integral part of the design process when siting grade control structures. A detailed study of all environmental features in the project area should be conducted early in the design process. This will allow these factors to be incorporated into the plan at the beginning to prevent having to make costly and often less environmentally effective last minute modifications to the final design.

807.4.3.5 Existing Structures

Bed degradation can cause significant damage to bridges, culverts, pipelines, utility lines, and other structures along the stream. Grade control structures can prevent this degradation and thereby provide protection to these structures. Grade control structures can also have adverse effects on existing structures, such as the potential increased stages and sediment deposition upstream of hydraulic control structures.

807.4.3.6 Local Site Conditions

When planning grade control structures, the final siting is often adjusted to accommodate local site conditions, such as the planform of the stream or local drainage. A stable upstream straight approach into the structure is desirable. During the initial siting of the structure, all local drainage (inflows from tributaries, field drains, road side ditches, or other sources) should be identified. Ideally, the structure should be sited to avoid local drainage conflicts.

807.4.3.7 Downstream Channel Response

Bed control structures reduce the downstream sediment loading by alleviating the bed and/or bank erosion, while hydraulic control structures have the effect of trapping sediments. The ultimate response of the downstream channel to the reduction in sediment supply needs to be evaluated.

807.4.3.8 Geologic Controls

Geologic controls can provide grade control in a similar manner to a bed control structure. In some instances, an existing geologic control can be utilized to serve as a grade control structure. However, caution needs to be exercised when relying on geologic outcrops to provide long-term grade control. In situations where geologic controls are to be used as long-term grade control structures, a detailed geotechnical investigation to determine the vertical and lateral extent of the outcrop is necessary.

807.4.3.9 Effects on Tributaries

The effect of main stream structures on tributaries should be evaluated when siting grade control structures. Degradation on a main stream channel may migrate upstream and it may branch up into the tributaries. If possible, main stream structures should be placed

downstream of tributary confluences in order to provide grade control to both the main stem and the tributaries.

807.4.4 TYPES OF GRADE CONTROL STRUCTURES

The common features to most grade control structures include a control section for accomplishing the grade change, a section for energy dissipation, and protection of the upstream and downstream approaches. A grade control structure can be constructed of riprap, concrete, sheet piling, treated lumber, soil cement, gabions, compacted earth fill, or other locally available materials. It can also have various shapes (sloping or vertical drop) and dimensions as well as appurtenances (baffle plates, end sills, etc.).

The appropriateness of a particular type of structure to any particular instance depends on a number of factors such as, hydrologic conditions, sediment size and loading, channel morphology, flood plain and valley characteristics, availability of construction materials, project objectives, and time and funding constraints. Some of the more common types of grade control structures are discussed in the following sections. For more information, see Neilson et al. (1991), which provides a comprehensive international literature review on grade control structures with an annotated bibliography.

807.4.4.1 Bed Sills

A simple form of grade control structures consists of rock, concrete rubble, or some other locally available non-erodible material dumped across the channel to form a hard point. These structures are often called rock sills, or bed sills. These types of structures are usually effective in small streams and where the drop heights are typically less than about 2 to 3 feet.

The designer should ensure that sufficient volume of non-erodible material (launching rock) be placed to resist the general bed degradation and the local scour at the structure. Figure 832 illustrates a riprap grade control structure designed to resist both the general bed degradation of the approaching knickpoint and any local scour at the structure.

807.4.4.2 Structures with Cutoff Walls

One common problem associated with bed sills is the displacement of rock (or rubble, etc.) due to the seepage flow around and beneath the structure. This problem can be solved by constructing a water barrier at the structure. One type of water barrier can be installed by simply placing a trench of impervious clay fill upstream of the weir crest. This is illustrated in Figure 833. One problem with this type of barrier is its longevity due to susceptibility to erosion. This problem can be overcome by using concrete or sheet piling for the cutoff wall. A conceptual design of a riprap grade control structure with a sheet pile cutoff wall is illustrated in Figure 834.

Figure 835 shows the design of a sloping riprap drop structure used by the Denver Urban Drainage and Flood Control District. In this case, an impervious clay fill is used in conjunction with a lateral cutoff wall (McLaughlin Water Engineers, Ltd., 1986).

807.4.4.3 Structures with Pre-Formed Scour Holes

A significant feature in Figure 835 is the pre-formed, rock protected scour holes. A rock grade control structure must have sufficient launching rock to protect against the vertical scour immediately below the weir section. At the same time, the lateral extent of the scour hole must also be constrained to ensure that it does not become so large that the structure is subject to being flanked. With many simple grade control structures in small stream

applications, very little attention is given to the design of a stilling basin or pre-formed scour hole, instead, the scour hole is allowed to form by erosion. However, at higher flow and drop situations, a pre-formed scour hole protected with concrete, riprap, or some other erosion resistant materials is usually warranted. This scour hole serves as a stilling basin for dissipating the energy of the plunging flow. Sizing of the scour hole is an important component in the design process.

The stability of rock structures is often in question at low tailwater conditions due to the instability of the rock. One method to ensure the stability of the rock is to design the structure to operate in a submerged condition. The U.S. Army Corps of Engineers (1970) shows the design of a bed stabilizer on the basis of this submerged condition.

In many instances, the energy dissipation in a grade control structure is achieved by the plunging action of the flow into the riprap protected stilling basin. This is generally satisfactory where the degree of submergence is relatively high due to small drop heights and/or high tailwater conditions. However, at lower submergence conditions where drop heights are large or tailwater is low, some additional means of dissipating the energy need be provided. Little and Murphey (1982) observed that an undular hydraulic jump occurs when the incoming Froude number is less than 1.7. Consequently, Little and Murphey developed a grade control design that included an energy dissipating baffle to break up these undular waves. This structure, referred to as the ARS type low-drop structure, has been used successfully in North Mississippi for drop heights up to about six feet by both the U.S. Army Corps of Engineers and the Soil Conservation Service (U.S. Army Corps of Engineers, 1981). A modification to the ARS structure was made following model studies at Colorado State University (Johns et al., 1993; and Abt et al., 1994). The modified ARS structure retains the baffle plate but adopts a vertical drop at the sheet pile replacing a sloping rock-fill section.

807.4.4.4 Concrete Drop Structures

In situations where the discharges and/or drop heights are large, grade control structures are often constructed of concrete. There are many different designs for concrete grade control structures. Two types of structures, the CIT and the St. Anthony Falls (SAF) are shown in Figures 839 and 840.

The CIT structure is generally applicable to low-drop situations where the ratio of the drop height to critical depth is less than one. The SAF structure is suitable in flow conditions where the drop height to critical depth ratio is greater than one and can provide effective energy dissipation within a Froude number range of 1.7 to 17.

807.4.4.5 Channel Linings

Grade control can also be achieved by lining the channel bed with non-erodible materials. The drop of the lined channel bed is accomplished over a specified reach of the channel.

807.4.4.6 Alternative Construction Materials

While riprap and concrete may be the most commonly used construction materials for grade control structures, many situations where cost or availability of materials may prompt the engineer to consider other alternatives. Gabion grade control structures are often an effective alternative to the standard riprap or concrete structures (Hanson et al., 1986). Agostini et al. (1988) provides design criteria for vertical, stepped, and sloped type gabion grade control structures, as well as examples of completed works. Guidance for the construction of gabion weirs can be found in the Corps of Engineers' ETL 1110-2-194.

Another alternative to the conventional riprap or concrete structure which has gained popularity in the southwestern U.S. is the use of soil cement grade control structures. These structures are constructed of onsite soil-sand in a mix with Portland cement to form a high quality, erosion resistant mixture. Soil cement grade control structures are most applicable when used as a series of small drops in lieu of a single large-drop structure. Experience has indicated that a limiting drop height for these structures is on the order of three feet. Design criteria for these structures are presented by Simons, Li, & Associates, Inc. (1982).

807.4.5 DROP STRUCTURE DESIGN

The grouted sloping boulder drop structure and the vertical riprap drop structure designs can be adapted for use as check structures. The analysis steps are the same with the additional consideration of: 1) stable bed slope for the unlined low-flow channel, and 2) potential overflow erosion during submergence of the check structure and where flow converges back from the main channel sides or below the check structure.

The basic design steps for this type of structure include the following:

- a. Determine a stable slope and configuration for the low flow zone. For unlined channels, discharges from full flood plain flow to the dominant discharge should first be considered. The dominant discharge is more fully explained in sediment transport texts such as Simons, Li and Associates (1982).
- b. The configuration of the low flow zone, and number and placement of the check structures has to be reviewed. Typically, the flood plain slope is steeper, often on the order of critical conditions. If the checks are widely spaced, the low-flow channel depth can be quite deep downstream of the check, leading to concentration of higher flows into the low-flow channel and the check. A good rule of thumb is to not have the low-flow channel more than 2 feet deep at the crest of the check, or more than 4 feet deep below the check structure (relative to the overbank).
- c. A hydraulic analysis should be performed using the discharge that completely fills the check structure at its crest (the primary design flow).
- d. The secondary design flow is that flow which causes the worst condition for lateral overflow around the abutments and back into the basin or low-flow channel below. The goal is to have the check structure survive such an event with minimal or reasonable damage to the flood plain below. The best approach is to estimate unit discharges, velocities and depths along overflow paths. The unit discharges can be estimated at the crest or critical section for the given total flow. Estimating the overflow path around the check abutment is difficult and requires practical judgment. Slopes can be derived for the anticipated overflow routes and protective measures devised such as grouted rock.
- e. Seepage control is also important, as piping and erosion through or around these structures is a frequent problem. It is advisable to provide a cutoff which extends laterally at least 5 to 10 feet into undisturbed bank at minimum and has a cutoff depth appropriate to the profile dimensions of the check.

807.4.6 CONTROL SILL DESIGN

Another type of check structure which can be used to stabilize low-flow channels within wide, relatively stable flood plains is the control sill shown in Figure 841. The sill can be constructed by filling an excavated trench with concrete if soil conditions are acceptable for trenching, or forming a simple wall if a trench will not work.

The sill crosses the low-flow channel and should extend a significant distance into the adjacent flood plain on both sides. The top of the sill conforms with the top of the ground at all points along its length. Riprap or other erosion control methods can then be added as erosion occurs.

The basic design steps are:

- a. Determine a stable slope as described above
- b. Determine spacing of the sills based on the difference in slope between the natural and projected stable slope and the amount of future drop to be allowed (not to exceed 3 feet)

808 EXAMPLE APPLICATION

808.1 EXAMPLE: OPEN CHANNEL DESIGN FOR DOE CREEK

Problem:

An open channel is to be constructed for Doe Creek downstream of John Boulevard and north of Rose Subdivision. Assume the following conditions for this problem.

$Q_{100} = 191$ cfs
 Invert elevation downstream of John Boulevard = 4,918 ft
 Invert elevation downstream of Rose Subdivision = 4,917 ft
 Channel improvement length = 900 ft
 Perennial flow = 5.6 cfs

Due to aesthetics and sufficient right-of-way, a grass-lined channel shall be constructed.
 Side Slope = $z = 3$
 Bottom width = $b = 10$ ft
 $n = 0.035$ for grass-lined channel

A low-flow channel shall be constructed in the proposed channel bottom.

Solution:

Step 1: Determine the depth of water during a 100-year flow event

$$\text{Slope} = (4918 - 4917)/900 = 0.0011 \text{ ft/ft}$$

The Manning Equation can be re-written so that the depth of flow, y , in a trapezoidal channel is on one side of the equation.

$$\frac{(by = zy^2)^{5/3}}{\left[\left(b + 2y(1 + z^2)^{1/2} \right) \right]^{2/3}} = \left(\frac{Q}{S^{1/2}} \right) \left(\frac{n}{1.49} \right)$$

Solving by trial and error,

$$Y = 3.7 \text{ ft}$$

Step 2: Calculate the water velocity in the proposed channel during a 100-year flow event using the Manning Equation.

$$\begin{aligned}
 V &= \frac{1.49}{n} S^{1/2} R^{2/3} \\
 &= \frac{1.49}{0.035} 0.0011^{1/2} \left[\frac{(10 + 3 \times 3.7) \times 3.7}{(10 + 2 \times 3.7 \times (1 + 3^2)^{1/2})} \right]^{2/3} \\
 &= 2.5 \text{ ft/sec.}
 \end{aligned}$$

Since the water velocity of the proposed channel (2.5 ft/sec) is less than the maximum permissible water velocity in a grass-lined channel, a grass-lined channel can be used at this location.

Step 3: Design the low-flow channel

Assume the dimensions for a concrete low-flow channel are:

Bottom width = 5 ft
 Depth = 1 ft
 Side slopes = vertical

The capacity of the low-flow channel is:

$$\begin{aligned}
 Q &= \frac{1.49}{n} S^{1/2} R^{2/3} A \\
 Q &= \frac{1.49}{n} S^{1/2} [by / (b + 2y)]^{2/3} by \\
 Q &= \frac{1.49}{0.015} \times 0.0011^{1/2} \times [5 \times 1 / (5 + 2 \times 1)]^{2/3} \times 5 \times 1 \\
 Q &= 13.16 \text{ cfs}
 \end{aligned}$$

Step 4: Verify that the low-flow channel has sufficient capacity

The minimum capacity of the low-flow channel is:

Min. $Q_f = 5.6 \text{ cfs}$ (perennial flow)

Since the capacity of the proposed low-flow channel (13.2 cfs) is greater than the required capacity (5.6 cfs), the proposed low-flow channel is adequate.

Step 5: Determine the freeboard required for the proposed channel

$$\begin{aligned}
 F_b &= 0.5 + (V^2 / 2g) \\
 F_b &= 0.5 + 2.5^2 / (2 \times 32.2) = 0.6, \text{ but minimum} = 1.0 \text{ ft.}
 \end{aligned}$$

Therefore, use $F_b = 1.0 \text{ ft}$.

Step 6: The cross-section of the proposed channel is shown in Figure 842.

808.2 EXAMPLE: DETERMINE EQUILIBRIUM SLOPE BY THE THREE SLOPE METHOD

Problem:

Determine the equilibrium slope by the three slope method based on the criteria proposed by Meyer-Peter and Muller.

The following data is known:

- Dominant discharge $Q = 500 \text{ ft}^3/\text{sec}$
- Channel width $B = 300 \text{ ft}$
- Mean channel depth $D = 1.5 \text{ ft}$
- Existing stream gradient $S_0 = 0.0015$
- Bed material: $d_{50} = 0.3 \text{ mm}$, $d_{90} = 0.96 \text{ mm}$
- Manning's roughness $n = 0.03$
- Original bed elevation = 5000 ft

Preliminary estimate of sand deposit is 1500 acre-feet, which would deposit behind a dam during the 100-year life of structure. It can be assumed that an equal volume of sand could be eroded from the downstream channel.

Solution:

Meyer-Peter and Muller method (see Figure 843)

Limiting slope

$$S_L = \left[K_1 d_{50} \left(n / (d_{90}^{1/6}) \right)^{3/2} \right] / D$$

$$= \left[0.19 \times 0.3 \left(0.03 / (0.96)^{1/6} \right)^{3/2} \right] / 1.5 = 0.000199$$

$$\Delta S = S_0 - S_L = 0.0015 - 0.000199 = 0.001301$$

$$A_g = \text{volume of material to be degraded per unit channel width}$$

$$= 1500 \times 43560 / 300 = 217800 \text{ ft}^2$$

$$D_g = \text{depth of degradation at the dam} = (64 A_g \Delta S / 39)^{1/2}$$

$$= (64 \times 217800 \times 0.001301 / 39)^{1/2} = 21.6 \text{ ft}$$

$$L_g = (13 D_g) / (8 \Delta S) = (13 \times 21.6) / (8 \times 0.001301) = 26979 \text{ ft}$$

$$L_1 = (D_g) / (2 \Delta S) = (21.6) / (2 \times 0.001301) = 8301 \text{ ft}$$

$$L_2 = (3 D_g) / (8 \Delta S) = (3 \times 21.6) / (8 \times 0.001301) = 6226 \text{ ft}$$

$$L_3 = (3 D_g) / (4 \Delta S) = (3 \times 21.6) / (4 \times 0.001301) = 12452 \text{ ft}$$

$$A_1 = (3 D_g^2) / (8 \Delta S) = (3 \times 21.6^2) / (8 \times 0.001301) = 134481 \text{ ft}^2$$

$$A_2 = (9 D_g^2) / (64 \Delta S) = (9 \times 21.6^2) / (64 \times 0.001301) = 50430 \text{ ft}^2$$

$$A_3 = (3 D_g^2) / (32 \Delta S) = (3 \times 21.6^2) / (32 \times 0.001301) = 33620 \text{ ft}^2$$

Calculated results from above can be used to construct the three-slope equilibrium bed profile. The original bed elevations at the end of reach L1, L2, and L3 are calculated as follows:

$$S_0 = (5000 - Y_1)/L_1, \quad Y_1 = 5000 - 0.0015 \times 8301 = 4987.65\text{ft}$$

$$S_0 = (5000 - Y_2)/(L_1 + L_2), \quad Y_2 = 5000 - 0.0015 \times (8301 + 6226) = 4978.21\text{ft}$$

$$S_0 = (5000 - Y_3)/L_g, \quad Y_3 = 5000 - 0.0015 \times 26979 = 4959.53$$

The bed elevation at the beginning of reaches L1, L2 and L3 can be calculated as follows:

$$Z_1 = 5000 - 21.6 = 5000 - 21.6 = 4978.4\text{ft}$$

$$Z_2 = 5000 - 21.6 = 4978.65 - 21.6 = 4976.75\text{ft}$$

$$Z_3 = 5000 - 21.6 = 4978.21 - 21.6 = 4972.81\text{ft}$$

The equilibrium slopes of the three reaches are:

$$S_1 = S_L = 0.000199$$

$$S_2 = (4976.75 - 4972.81) / 6226 = 0.000633$$

$$S_3 = (4972.81 - 4959.53) / 12452 = 0.001066$$

808.3 EXAMPLE: DETERMINE THE EQUILIBRIUM SLOPE BY POWER RELATIONS

Problem:

Determine the equilibrium slope by power relations

The following data is given:

Dominant Discharge: $Q = 800$ cfs

Upstream Reach

Channel shape: Trapezoidal
 Channel bottom width $B = 40$ ft
 Side slope: 2H:1V
 Existing stream gradient $S_0 = 0.02$
 Bed material: $d_{50} = 1$ mm, $G_r = 3$ (Gradation coefficient)
 Manning's roughness $n = 0.02$

Design Reach

Channel shape: Trapezoidal
 Channel bottom width $B = 50$ ft
 Side slope: 2H:1V
 Existing stream gradient $S_0 = 0.01$
 Bed material: $d_{50} = 1$ mm, $G_r = 3$ (Gradation coefficient)
 Manning's roughness $n = 0.02$

Solution:

The derivative hydraulic characteristics for the upstream reach are:

Depth (to bottom): 2.19 ft
 Flow area: 97.2 ft²
 Top width: 48.76 ft
 Average Velocity: 8.23 ft/sec
 Hydraulic depth: 1.99 ft

The coefficients for the power relation (from Table 805) are:

C1 = 9.14 x 10⁻⁶
 C2 = 0.18
 C3 = 3.76

Therefore,

$$q_s = 9.14 \times 10^{-6} Y_h^{0.18} V^{3.76}$$

The sediment transport rate for the upstream reach is:

$$q_s = 9.14 \times 10^{-6} 1.99^{0.18} 8.23^{3.76} = 0.0286 \text{ cfs/ft}$$

$$Q_s = 0.0286 \times 48.76 = 1.40 \text{ cfs}$$

The next step is to determine the equilibrium slope for the design reach with a sediment supply rate of 1.40 cfs. The following table summarizes the calculation results.

Summary of Equilibrium Slope Calculation

Slope	Depth (ft)	Area (ft ²)	Velocity (ft/sec)	Hydraulic Depth (ft)	Top Width (ft)	Froude number	Q _s (cfs)
0.01	1.569	83.37	9.60	1.48	56.28	1.39	2.72
0.006	1.826	97.97	8.17	1.71	57.30	1.10	1.55
0.0055	1.873	100.67	7.95	1.75	57.49	1.06	1.40





The equilibrium slope is 0.0055.

An incipient motion check indicates that the critical particle size is 1.46 inches (37 mm); therefore, armoring will not be a problem. Due to the design slope being 0.01, which is greater than the equilibrium slope, head-cutting will occur.

References

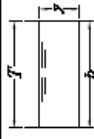
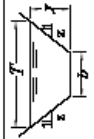
- ASCE, 1975 - American Society of Civil Engineers, *Sedimentation Engineering, Manuals and Reports on Engineering Practice No. 54* (ASCE, New York, 1975).
- Bruthurst, 1979 - J.C. Bruthurst, R.M. Li, and D.B. Simons, *Hydraulics of Mountain Rivers* (Civil Engineering Department, Colorado State University, CER78-78JCB-RML-DBS55, 1979).
- Chow, 1959 - Chow, V. T., *Open Channel Hydraulics* (McGraw-Hill Book Company, 1959).
- Federal Interagency Stream Restoration Work Group (FISWRG), *Stream Corridor Restoration: Principles, Processes, and Practices* (2001).
- Fortier, 1926 - S. Fortier and F. C. Scobey, *Permissible Canal Velocities, Transactions* (American Society of Civil Engineers, Volume 89, pp 940-956, 1926).
- McLaughlin Water Engineers, Ltd., *Evaluation of and Design Recommendations for Drop Structures in the Denver Metropolitan Area* (December 1986).
- SCS, 1996 – *The NRCS Engineering Field Handbook, Part 650, Chapter 16, Streambank and Shoreline Protection* (USDA-NRCS 1996).
- SCS, 1996 – *The NRCS Engineering Field Handbook, Part 650, Chapter 18, Soil Bioengineering for Upland Slope Protection and Erosion Reduction* (USDA-NRCS 1992).
- Simons, 1989 - Simons, Li and Associates, *Surface Mining Water Diversion Design Manual* (September 1982), US Department of Interior, Office of Surface Mining Reclamation and Enforcement, 1989).
- Smith, 1965 - Smith, C.D., and Murray, D.G., *Cobble Lined Drop Structures* (2nd Canadian Hydro-Technical Conference, Burlington, Ontario, 1965).
- Stevens, 1981 - Stevens, Michael, A., *Hydraulic Design Criteria for Riprap Chutes and Vertical Drop Structures* (Urban Drainage and Flood Control District, 1981).
- USACE, 1970 - *Hydraulic Design of Flood Control Channels, EM 1110-2-1601* (US Army Corps of Engineers, Washington, DC, July 1970).
- USACE, 1990B - *HEC-2, Water Surface Profiles* (Davis, California, September 1990).
- USEPA, 1976 - *Erosion and Sediment Control, Surface Mining in the Eastern US* (US Environmental Protection Agency, EPA-625/3-76-006, Washington, DC, 1976).

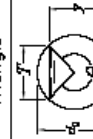
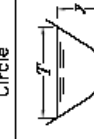
GEOMETRIC ELEMENTS OF CHANNEL SECTIONS

SECTION	AREA, A	WETTED PERIMETER, P	HYDRAULIC RADIUS, R	TOP WIDTH, T	HYDRAULIC DEPTH, D	SECTION FACTOR, Z
 Rectangle	by	$b+2y$	$\frac{by}{b+2y}$	b	y	$by^{1.48}$
 Trapezoid	$(b+zy)y$	$b+2y\sqrt{1+z^2}$	$\frac{(b+zy)y}{b+2y\sqrt{1+z^2}}$	$b+2zy$	$\frac{(b+zy)y}{b+2zy}$	$\frac{[(b+zy)y]^{1.48}}{\sqrt{b+2zy}}$
 Triangle	zy^2	$2y\sqrt{1+z^2}$	$\frac{zy}{2\sqrt{1+z^2}}$	$2zy$	$\frac{y}{2}$	$\frac{\sqrt{2}}{2} zy^{1.48}$
 Circle	$\frac{1}{8}(\theta - \sin\theta)d_0^3$	$\frac{1}{4}\theta d_0$	$\frac{1}{4}\left(\theta - \frac{\sin\theta}{\theta}\right)d_0$	$(\sin \frac{1}{2}\theta)d_0$ or $2\sqrt{y}(d_0 - y)$	$\frac{1}{4}\left(\theta - \frac{\sin\theta}{\theta}\right)d_0$	$\frac{\sqrt{2}}{32} \frac{(\theta - \sin\theta)^{1.48}}{(\sin \frac{1}{2}\theta)^{0.48}} d_0^{1.48}$
 Parabola	$\frac{1}{6}Ty$	$T + \frac{8}{3}\frac{y^2}{T}$	$\frac{2Ty^2}{3T^2 + 8y^2}$	$\frac{3}{2}\frac{A}{y}$	$\frac{2y}{3}$	$\frac{1}{6}\sqrt{6} Ty^{1.48}$
 Round-bottomed rectangle ($y > r$)	$(\frac{\pi}{2} - 2)r^2 + (b+2r)y$	$(\pi - 2)r + b + 2y$	$\frac{(\pi/2 - 2)r^2 + (b+2r)y}{(\pi - 2)r + b + 2y}$	$b+2r$	$\frac{(\pi/2 - 2)r^2}{b+2r} + y$	$\frac{[(\pi/2 - 2)r^2 + (b+2r)y]^{1.48}}{\sqrt{b+2r}}$
 Round-bottom triangle	$\frac{T^3}{4z} - \frac{T^2}{2}(1 - z \cot^{-1} z)$	$\frac{T}{2}\sqrt{1+z^2} - \frac{2T}{z}(1 - z \cot^{-1} z)$	$\frac{A}{P}$	$2[x(y-r) + r\sqrt{1+x^2}]$	$\frac{A}{T}$	$A\sqrt{\frac{A}{T}}$

*Satisfactory approximation for the interval $0 < x \leq 1$, where $x = 4y/T$. When $x > 1$, use the exact expression $P = (T/2)[\sqrt{1+x^2} + 1/x \ln(x + \sqrt{1+x^2})]$

April 30, 2009

WTC ENGINEERING, INC.

REFERENCE:
Chow, V.T., 1959, Open-Channel Hydraulics

TABLE
801

TYPICAL ROUGHNESS COEFFICIENTS FOR OPEN CHANNELS

<u>TYPE OF CHANNEL AND DESCRIPTION</u>	<u>MINIMUM</u>	<u>NORMAL</u>	<u>MAXIMUM</u>
EXCAVATED OR DREDGED			
a. Earth, straight and uniform			
1. Clean, recently completed	0.016	0.018	0.020
2. Clean, after weathering	0.018	0.022	0.025
3. Gravel, uniform section, clean	0.022	0.025	0.030
4. With short grass, few weeds	0.022	0.027	0.033
b. Earth, winding and sluggish			
1. No vegetation	0.023	0.025	0.030
2. Grass, some weeds	0.025	0.030	0.033
3. Dense weeds or aquatic plants in deep channels	0.030	0.035	0.040
4. Earth bottom and rubble sides	0.028	0.030	0.035
5. Stony bottom and weedy banks	0.025	0.035	0.040
6. Cobble bottom and clean sides	0.030	0.040	0.050
c. Dragline-excavated or dredged			
1. No vegetation	0.025	0.028	0.033
2. Light brush on banks	0.035	0.050	0.060
d. Rock cuts			
1. Smooth and uniform	0.025	0.035	0.040
2. Jagged and irregular	0.035	0.040	0.050
e. Channels not maintained, weeds and brush			
1. Dense weeds, high as flow depth	0.050	0.080	0.120
2. Clean bottom, brush on sides	0.040	0.050	0.080
3. Same as above, but highest stage of flow	0.045	0.070	0.110
4. Dense brush, high stage	0.080	0.100	0.140
NATURAL STREAMS			
Minor Streams (top width at flood stage < 100 ft)			
a. Streams on plain			
1. Clean, straight, full stage, no rifts or deep pools	0.025	0.030	0.033
2. Same as above, but more stones and weeds	0.030	0.035	0.040
3. Clean, winding, some pools and shoals	0.033	0.040	0.045
4. Same as above, but some weeds and stones	0.035	0.045	0.050
5. Same as above, but lower stages, and more ineffective slopes and sections	0.040	0.048	0.055

TYPICAL ROUGHNESS COEFFICIENTS FOR OPEN CHANNELS

<u>TYPE OF CHANNEL AND DESCRIPTION</u>	<u>MINIMUM</u>	<u>NORMAL</u>	<u>MAXIMUM</u>
6. Same as 4, but more stones	0.045	0.050	0.060
7. Sluggish reaches, weedy, deep pools	0.050	0.070	0.080
8. Very weedy reaches, deep pools, or floodways with heavy stand of timber and underbrush	0.075	0.100	0.150
b. Mountain streams, no vegetation in channel, banks usually steep, trees and brush along banks submerged at high stages			
1. Bottom: gravel, cobbles, and few boulders	0.030	0.040	0.050
2. Bottom: cobbles with large boulders	0.040	0.050	0.070
Flood plains			
a. Pasture, no brush			
1. Short grass	0.025	0.030	0.035
2. High grass	0.030	0.035	0.050
b. Cultivated areas			
1. No crop	0.020	0.030	0.040
2. Mature row crops	0.025	0.035	0.045
3. Mature field crops	0.030	0.040	0.050
c. Brush			
1. Scattered brush, heavy weeds	0.035	0.050	0.070
2. Light brush and trees, in winter	0.035	0.050	0.060
3. Light brush and trees, in summer	0.040	0.060	0.080
4. Medium to dense brush, in winter	0.045	0.070	0.110
5. Medium to dense brush, in summer	0.070	0.100	0.160
d. Trees			
1. Dense willows, summer, straight	0.110	0.105	0.200
2. Cleared land with tree stumps, no sprouts	0.030	0.040	0.050
3. Same as above, but with heavy growth of sprouts	0.050	0.060	0.080
4. Heavy stand of timber, a few down trees, little undergrowth, flood stage below branches	0.080	0.100	0.1200
5. Same as above, but with flood stage reaching branches	0.100	0.120	0.160
Major Streams (top width at flood stage > 100 ft). The <i>n</i> value is less than that for minor streams of similar description, because banks offer less effective resistance			
a. Regular section with no boulders or brush	0.025	---	0.060
b. Irregular and rough section	0.035	---	0.100

VERSION: April 30, 2009

REFERENCE:
Chow, V.T., 1959, Open-Channel Hydraulics

TABLE
802
2 of 3

WTC ENGINEERING, INC.

TYPICAL ROUGHNESS COEFFICIENTS FOR OPEN CHANNELS

<u>TYPE OF CHANNEL AND DESCRIPTION</u>	<u>MINIMUM</u>	<u>NORMAL</u>	<u>MAXIMUM</u>
LINED OR BUILT-UP CHANNELS			
a. Corrugated Metal	0.021	0.025	0.030
b. Concrete			
1. Trowel finish	0.011	0.013	0.015
2. Float finish	0.013	0.015	0.016
3. Finished, with gravel on bottom	0.015	0.017	0.020
4. Unfinished	0.014	0.017	0.020
5. Gunite, good section	0.016	0.019	0.023
6. Gunite, wavy section	0.018	0.022	0.025
7. On good excavated rock	0.017	0.020	---
8. On irregular excavated rock	0.022	0.027	---
c. Concrete bottom float finished with sides of:			
1. Dressed stone in mortar	0.015	0.017	0.020
2. Random stone in mortar	0.017	0.020	0.024
3. Cement rubble masonry, plastered	0.016	0.020	0.024
4. Cement rubble masonry	0.020	0.025	0.030
5. Dry rubble or riprap	0.020	0.030	0.035
d. Gravel bottom with sides of :			
1. Formed concrete	0.017	0.020	0.025
2. Random stone in mortar	0.020	0.023	0.026
3. Dry rubble or riprap	0.023	0.033	0.036
e. Asphalt			
1. Smooth	0.013	0.013	---
2. Rough	0.016	0.016	---
f. Grassed	0.030	0.040	0.050

MAXIMUM PERMISSIBLE MEAN CHANNEL VELOCITIES

MATERIAL/LINING	MAXIMUM PERMISSIBLE MEAN VELOCITY (ft/sec)
NATURAL AND IMPROVED UNLINED CHANNELS	
Fine sand, colloidal	1.50
Sandy Loam, noncolloidal	1.75
Silt Loam, noncolloidal	2.00
Alluvial Silts, noncolloidal	2.00
Ordinary Firm Loam	2.50
Volcanic Ash	2.50
Stiff Clay, very colloidal	3.75
Alluvial Silts, colloidal	3.75
Shales and Hardpans	6.00
Fine Gravel	2.50
Graded Loam to Cobbles when noncolloidal	3.75
Graded Silts to Cobbles when colloidal	4.00
Coarse Gravel, noncolloidal	4.00
Cobbles and Shingles	5.00
Sandy Silt	2.0
Silty Clay	2.5
Poor Sedimentary Rock	10
Sound Rock (Igneous or Hard Metamorphic)	20

FULLY LINED CHANNELS

Unreinforced vegetation	5
Loose riprap	15
Grouted riprap	15
Gabions	15
Soil-Cement	15
Concrete	35

NOTES:

1. For composite-lined channels, use the lowest of the maximum mean velocities for the materials used in the composite lining.
2. Deviation from the above values is only allowed with appropriate engineering analysis and/or suitable agreements for maintenance responsibilities.
3. Maximum permissible velocities based upon non-clear water conditions.

VERSION: April 30, 2009	REFERENCE: Natural – Fortier and Scobey, 1926 Fully Lined – Various Sources	TABLE 803
WTC ENGINEERING, INC.		

POTENTIAL EFFECTS OF MAJOR MAN-MADE DISTURBANCES

Potential Effects	Disturbances																				
	a	b	c	d	e	f	g	h	i	j	k	l	m	n	o	p	q	r	s	t	
1	D	D	D	D	D	I	I	D	D	D	D	D	I	D	D	I	I	D	D	D	
2	I	I	I	D	D	D	D	D	D	D	D	D	I	I	D	I	D	I	D	I	D
3	I	D	I	D	I	I	I	D	I	D	I	I	I	D	D	I	I	I	I	D	
4	I	D	I	D	D	D	D	D	D	D	D	D	I	D	I	I	D	D	I	D	
5	I	I	I	I	D	D	D	I	D	D	I	D	D	I	D	D	I	D	I	I	
6	I	D	I	I	I	I	D	I	I	D	I	I	D	I	D	I	I	D	I	I	
7	I	D	I	D	I	I	I	D	I	I	I	I	I	D	D	I	I	D	D	D	
8	I	I	D	D	D	I	D	D	D	I	D	D	D	I	D	D	D	D	I	I	
9	I	D	D	D	I	I	I	D	D	D	I	I	D	D	I	I	I	D	D	D	
10	I	D	D	D	D	D	D	D	D	D	D	D	D	D	D	I	I	D	I	D	
11	I	D	D	D	D	D	D	D	D	D	D	D	I	D	I	D	D	D	I	D	
12	D	D	D	D	D	D	D	D	D	D	D	D	D	D	I	D	D	D	I	D	
13	D	D	I	D	D	D	D	I	D	D	I	D	I	D	D	I	D	D	I	D	
14	I	I	D	I	D	D	D	D	D	D	D	D	D	I	I	I	I	D	D	I	
15	D	D	D	D	D	I	D	D	D	D	D	D	D	D	D	I	I	D	D	D	
16	I	D	D	I	D	D	I	D	D	D	D	D	D	I	I	I	I	D	I	I	
17	I	I	I	I	D	D	D	I	D	I	I	D	D	I	I	D	I	D	I	I	
18	I	D	D	D	I	I	I	D	I	D	D	I	I	D	D	I	I	I	I	D	
19	I	I	I	D	D	I	I	I	D	D	D	D	D	D	I	I	I	D	I	D	
20	I	D	D	D	I	I	I	D	D	D	I	I	D	D	I	I	I	D	I	D	
21	I	I	I	I	D	D	D	I	D	I	I	D	D	I	I	D	I	D	I	I	
22	I	D	D	D	D	D	D	D	D	I	D	D	I	D	I	I	I	I	D	I	
23	I	D	I	I	D	D	I	D	D	D	D	D	D	D	D	I	I	D	D	D	
24	I	I	D	D	D	D	I	D	D	D	D	D	D	I	I	I	I	D	D	D	
25	I	D	D	I	D	I	D	D	I	D	D	I	I	D	D	I	I	I	I	D	

"D" represents direct effect and "I" represents indirect effect.
See Section 804.1.5.2 for context.

**POWER EQUATIONS FOR TOTAL BED MATERIAL DISCHARGE
IN SAND- AND FINE-GRAVEL-BED STREAMS**

$q_s = C_1 (Y)^{C_2} (V)^{C_3}$								
d_{50}								
(mm)	0.1	0.25	0.5	1.0	2.0	3.0	4.0	5.0
(inches)	0.00394	0.00984	0.0197	0.0394	0.0787	0.118	0.157	0.197
$G_r = 1.0$								
C_1	3.30×10^{-5}	1.42×10^{-6}	7.60×10^{-6}	5.62×10^{-6}	5.64×10^{-6}	6.32×10^{-6}	7.10×10^{-6}	7.78×10^{-6}
C_2	0.715	0.495	0.28	0.06	-0.14	-0.24	-0.30	-0.34
C_3	3.30	3.61	3.82	3.93	3.95	3.92	3.89	3.87
$G_r = 2.0$								
C_1		1.59×10^{-5}	9.80×10^{-6}	6.94×10^{-6}	6.32×10^{-6}	6.62×10^{-6}	6.94×10^{-6}	
C_2		0.51	0.33	0.12	-0.09	-0.196	-0.27	
C_3		3.55	3.73	3.86	3.91	3.91	3.90	
$G_r = 3.0$								
C_1			1.21×10^{-5}	9.14×10^{-6}	7.44×10^{-6}			
C_2			0.36	0.18	-0.02			
C_3			3.66	3.76	3.86			
$G_r = 4.0$								
C_1				1.0510^{-5}				
C_2				0.21				
C_3				3.71				

Notes: q_s is unit sediment transport rate in cfs/ft (unbulked); V is velocity in ft/sec; Y is depth in ft; and G_r is gradation coefficient [$G_r = (d_{84}/d_{50} + d_{50}/d_{16})/2$].

**RANGE OF PARAMETERS
FOR THE SIMONS-LI-FULLERTON METHOD**

Parameter	Value Range
Froude number	1~4
Velocity	6.5 ~ 26 ft/sec
Manning Coefficient n	0.015 ~ 0.025
Bed Slope	0.005 ~ 0.040
Unit Discharge	10 ~ 200 cfs/ft
Particle Size	d ₅₀

VERSION: April 30, 2009

REFERENCE:

Simons-Li-Fullerton

TABLE
806

WTC ENGINEERING, INC.

CHECKLIST OF DATA NEEDS FOR NATURAL CHANNEL ANALYSIS

	Description of Data	Degree of Data Importance
Hydrology	Design discharges with anticipated urbanization Design hydrographs with anticipated urbanization Flood history (if available)	Primary Primary Secondary
Hydraulics	Channel geometry Bed slopes Backwater calculations Channel type (meandering, straight) Channel controls (drops, restrictions) Roughness coefficients	Primary Primary Primary Secondary Primary Primary
Soils	Bed material size distribution (geotechnical report) Bank material size distribution (geotechnical report)	Primary Primary
Hydraulic Structures (existing and planned structures)	Plans and design details Examine scour around existing hydraulic structures	Primary Secondary
Aerial Photographs	Recent and past photographs showing the channel and surrounding terrain	Primary
Land Use	Existing land use Planned land use maps	Primary Primary
Field Surveys	Topographic maps Onsite inspection and photographs Observe channel changes or realignment (if any) since last maps or photographs Sample sediments Subsurface exploration	Primary Primary Primary Primary Primary
Notes: 1. Primary – Required 2. Secondary – Desired but not essential		

VERSION: April 30, 2009	REFERENCE:	TABLE
WTC ENGINEERING, INC.		807

SUMMARY OF APPLICATIONS OF STREAM STABILIZATION TECHNIQUES

Applications	Techniques*														
	1	2	3	4	5	6	7	8	9	10	11	12	13	14	15
Aides natural regeneration colonization	x	x	x	x	x	x	x	x	x	x			x	x	x
Appropriate above and below bankfull				x	x					x	x		x		
Branches add tensile strength to the bank		x			x				x						x
Deflects strong or high flows when placed close together					x					x	x	x			
Facilitates drainage on wet sites, dries excessively wet sites			x					x		x					
Filter barrier to prevent erosion and scouring of the bank		x	x	x		x		x	x	x	x	x		x	x
Flexible, can be molded to existing contours				x						x	x	x		x	x
Good on lakes where water level fluctuates					x						x	x			
Helps establish sods and grasses				x						x					
Immediate protective cover for the bank			x	x			x				x			x	x
Instant habitat improvement															
Lakes and shorelines	x	x	x	x	x	x	x	x	x	x	x	x	x	x	x
Little site disturbance		x		x		x		x							
Maintains a natural bank appearance	x	x	x	x	x			x	x				x		
Manufactured in the field	x	x	x		x	x	x	x	x		x	x	x	x	x
Minimum site disturbance				x		x			x						
Maximum site disturbance during construction	x						x			x				x	x
Rapid reestablishment of riparian vegetation		x	x		x	x	x	x	x					x	x
Protects banks from shallow slides	x	x		x	x	x	x	x	x		x	x			
Reduces a long beach wash into shorter segments								x		x					
Reduces slope length		x		x	x			x	x		x	x		x	x
Reduces surface erosion	x			x				x			x			x	x
Reduces toe erosion			x	x			x	x	x	x	x	x	x	x	x
Reduces wind and water velocities hitting bank					x					x		x		x	
Retains moisture															
Roots stabilize banks	x	x	x		x	x	x	x	x					x	x
Survives fluctuating water levels					x						x	x		x	
Traps sediment	x	x	x	x		x	x	x		x	x	x	x	x	x
Useful where spaces is limited			x	x	x		x	x	x	x	x	x	x	x	x

* Techniques: 1= Bank Shaping and Planting; 2=Branch Packing; 3=Brush Mattresses; 4=Coconut Fiber Roll; 5=Dormant Post Plantings; 6=Joint Plantings; 7=Live Cribwalls; 8=Live Fascines; 9=Live Stakes; 10=Log, Rootwad, and Boulder Revetments; 11=Riprap; 12=Stone Toe Protection; 13=Tree Revetments; 14=Vegetated Gabions; 15=Vegetated Geogrids.

RIPRAP GRADATION FOR STEEP SLOPES

$$D_{\max} = 1.25 \times D_{50}$$

$$D_{20} = D_{50}/2$$

$$D_{10} = D_{50}/3$$

VERSION: April 30, 2009

REFERENCE:

Simons, 1989

TABLE
809

WTC ENGINEERING, INC.

OPEN-CHANNEL FLOW CONDITIONS

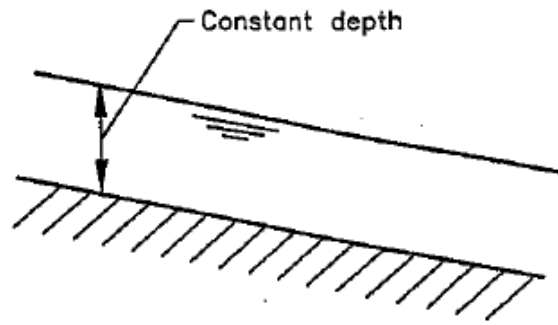

UNIFORM FLOW

Flow in a laboratory channel

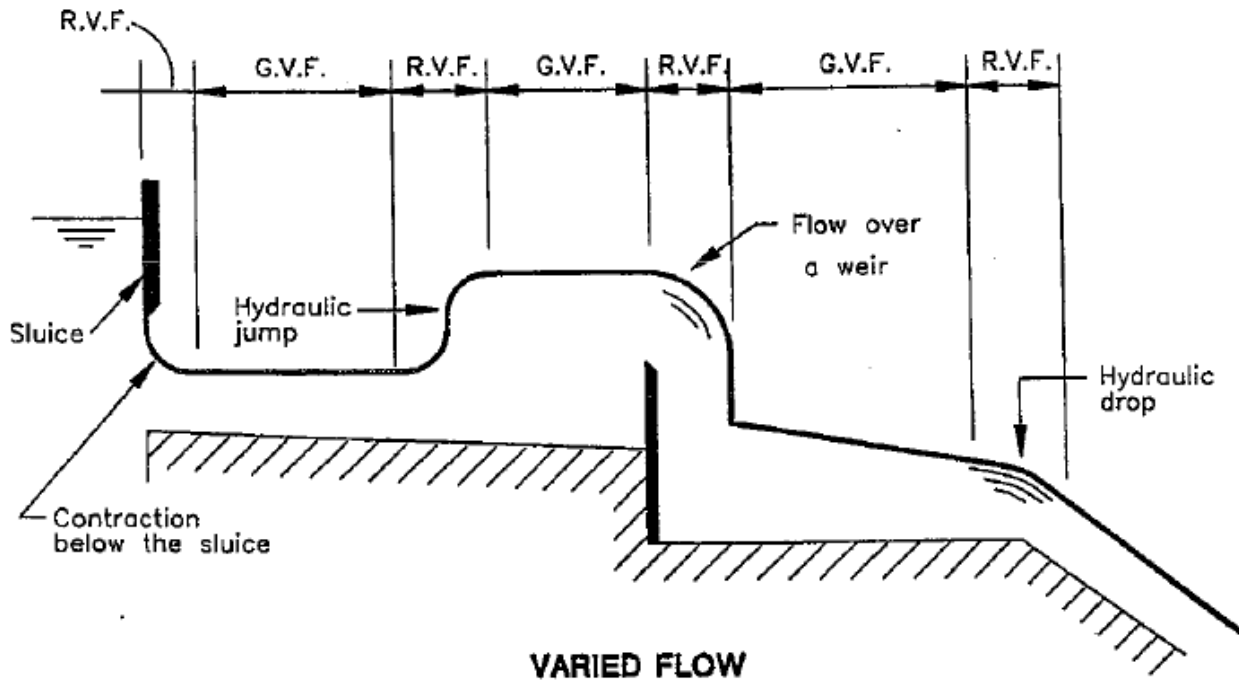

VARIED FLOW

G.V.F. – Gradually Varying Flow
 R.V.F. – Rapidly Varying Flow

VERSION: April 30, 2009

REFERENCE:

Chow, V.T. *Open-Channel Hydraulics*, 1959

FIGURE
801

WFC ENGINEERING, INC.

CRITICAL DEPTH FOR TRAPEZOIDAL AND CIRCULAR SECTIONS

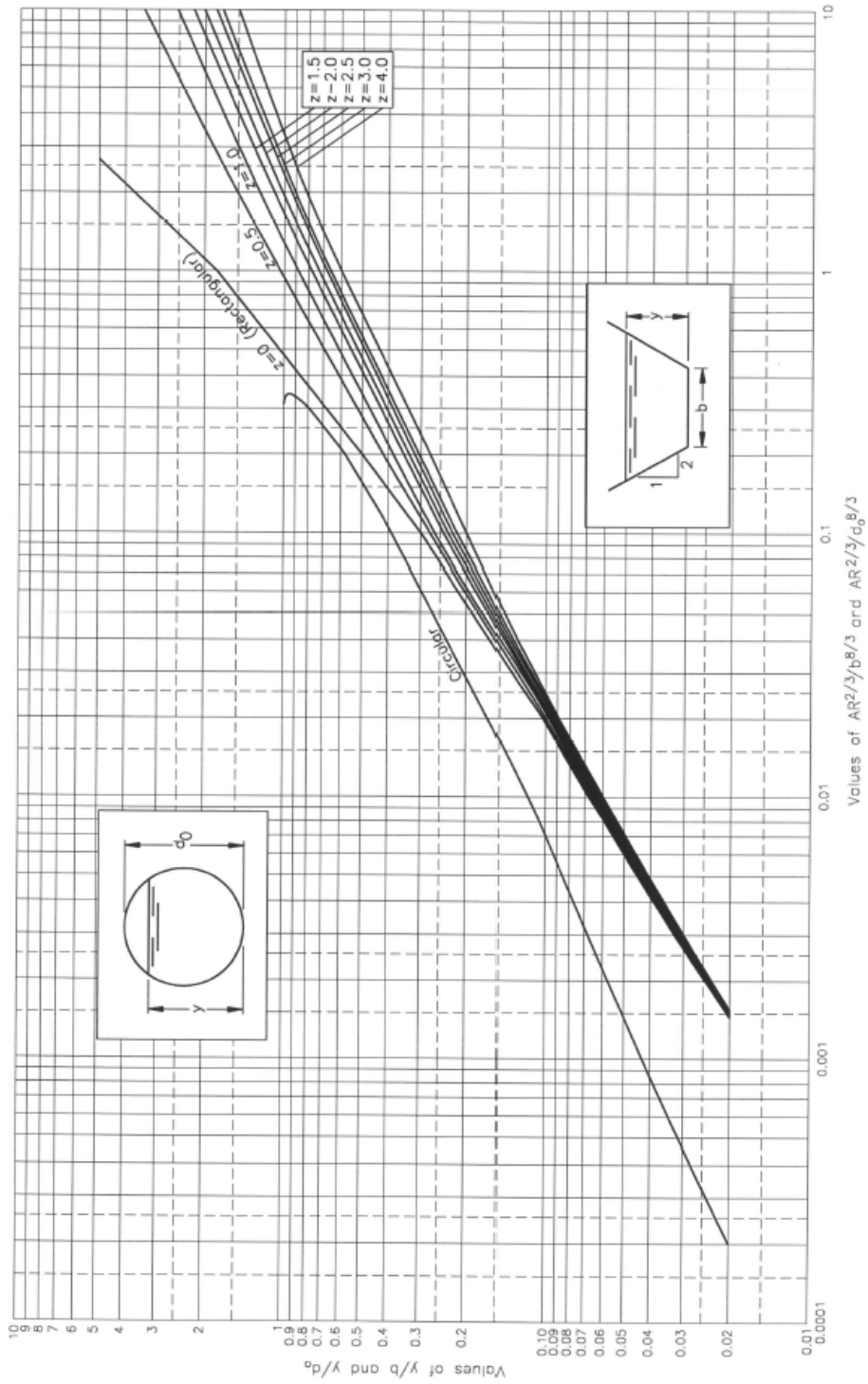

VERSION: April 30, 2009

WTC ENGINEERING, INC.

REFERENCE:

Chow, V.T. *Open-Channel Hydraulics*,
McGraw Hill Book Company, 1959

FIGURE
802

TYPICAL OPEN CHANNEL DESIGN SECTIONS
(NATURAL CHANNELS)

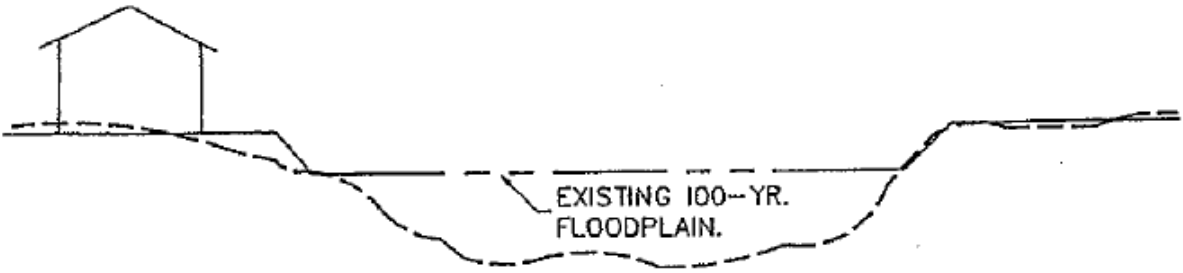

NATURAL UNENCROACHED CHANNEL

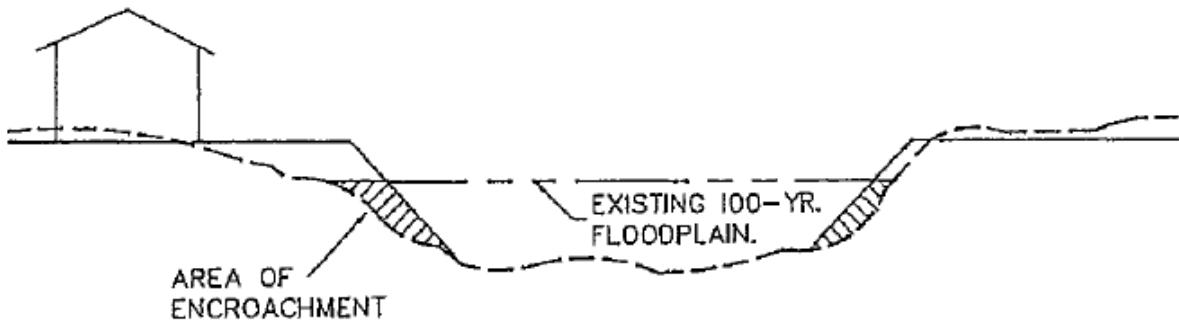

NATURAL ENCROACHED CHANNEL

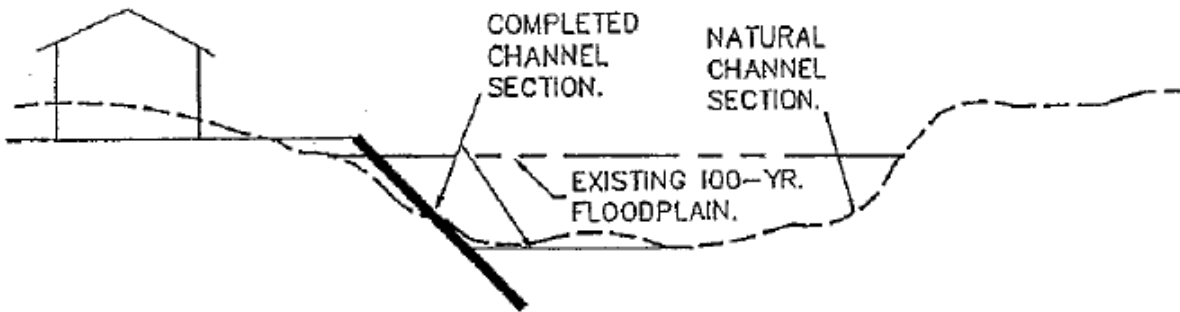

BANK LINED AND TEMPORARY UNLINED CHANNEL

VERSION: April 30, 2009

REFERENCE:

FIGURE
803

WJC ENGINEERING, INC.

ILLUSTRATION OF TERMINOLOGY FOR BEND-SCOUR CALCULATIONS

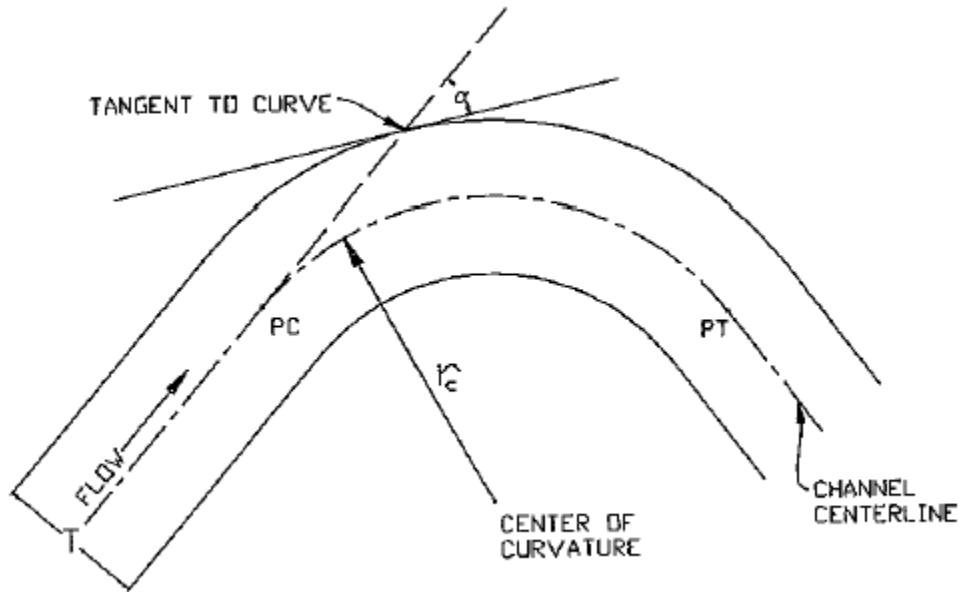

PT = Downstream point of tangency to the centerline radius of curvature
PT = Upstream point of curvature at the centerline radius of curvature

VERSION: April 30, 2009

REFERENCE:

FIGURE
804

WTC ENGINEERING, INC.

**FORCES ACTING ON A CHANNEL BANK
ASSUMING THERE IS ZERO PORE-WATER PRESSURE**

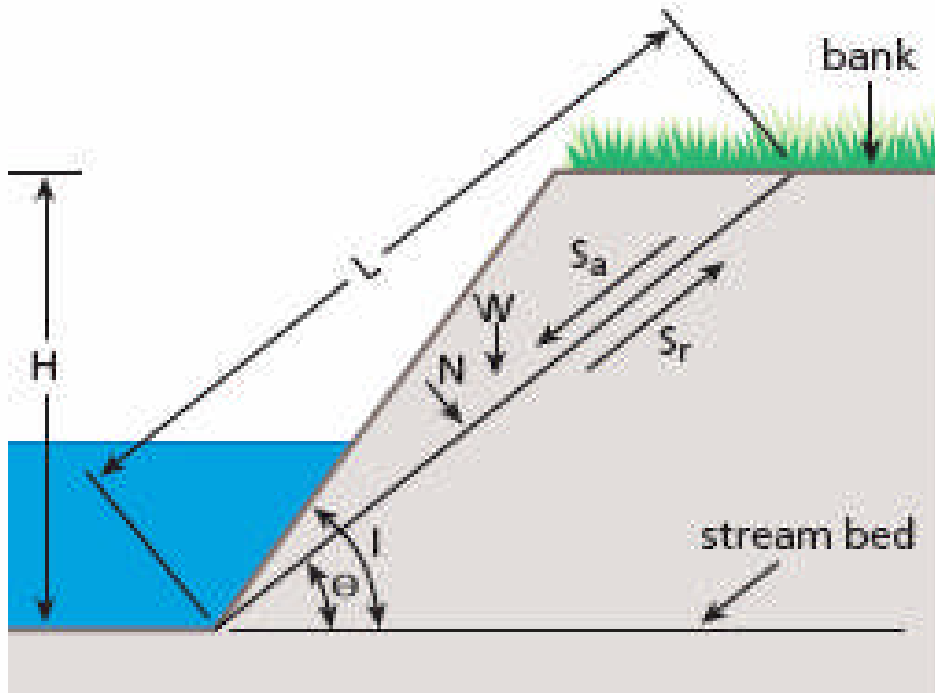

Explanation

- H = bank height
- L = failure plane length
- c = cohesion
- Φ = friction angle
- Y = bulk unit weight
- W – weight of failure block
- I = bank angle
- $S_a = W \sin \Theta$ (driving force)
- $S_r = cL + N \tan \Phi$ (resisting force)
- $N = W \cos \Theta$
- $\Theta = (0.51 = 0.5 \Phi)$ (failure plan angle)
- for the critical case $S_a = S_r$ and:

Soil properties

$$H_c = \frac{4c \sin I \cos \Phi}{\gamma (1 - \cos [I - \Phi])}$$

VERSION: April 30, 2009

REFERENCE:

FISRWG, 2001

FIGURE
805

WTC ENGINEERING, INC.

**STABILITY NUMBER (NS)
AS A FUNCTION OF BANK ANGLE (I)
FOR A FAILURE SURFACE PASSING THROUGH THE BANK TOE**

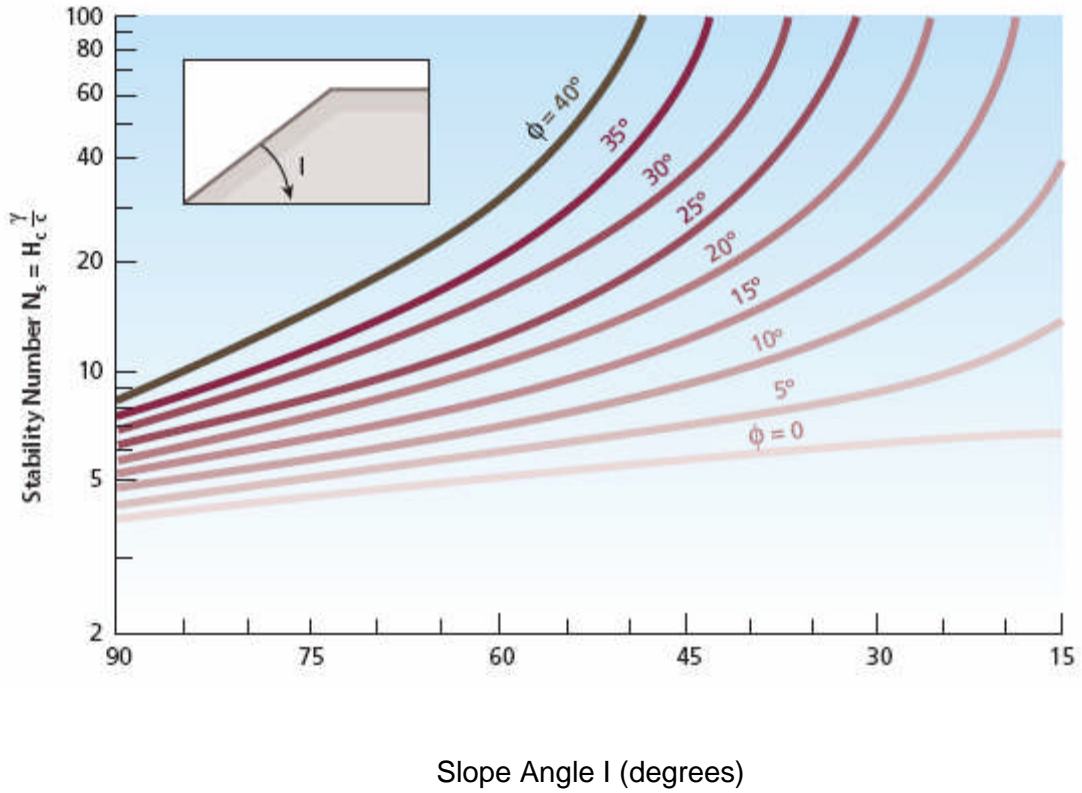

VERSION: April 30, 2009

REFERENCE:

Chen, 1975

FIGURE
806

WTC ENGINEERING, INC.

**EXAMPLE OF
A BANK STABILITY CHART
FOR ESTIMATING CRITICAL BANK HEIGHT (HC)**

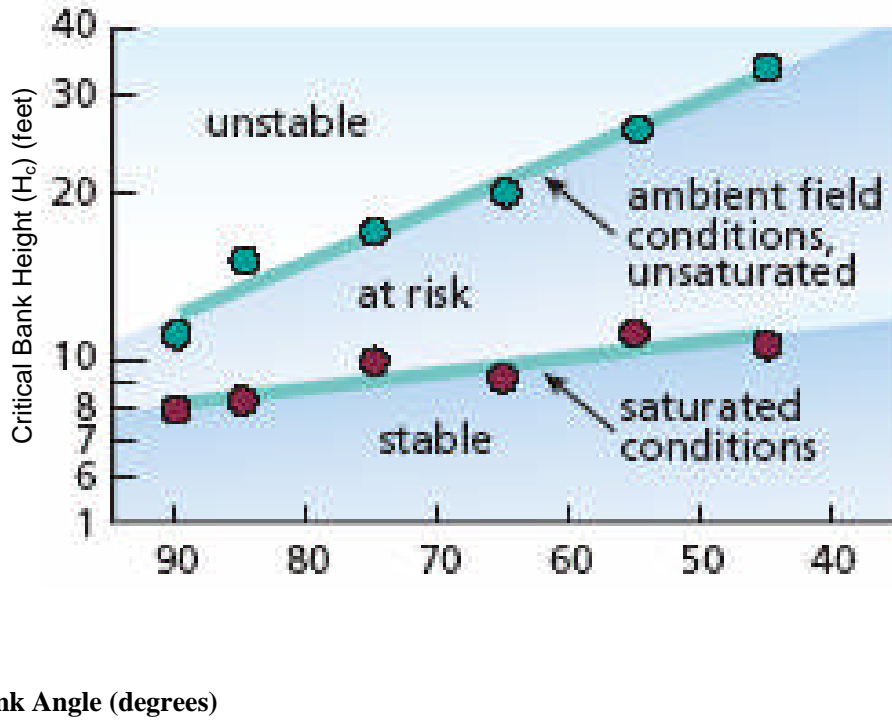

VERSION: April 30, 2009

REFERENCE:

FISRWG, 2001

FIGURE
807

WTC ENGINEERING, INC.

**CRITICAL BANK-SLOPE CONFIGURATIONS
FOR VARIOUS RANGES OF COHESIVE STRENGTHS UNDER SATURATED CONDITIONS**

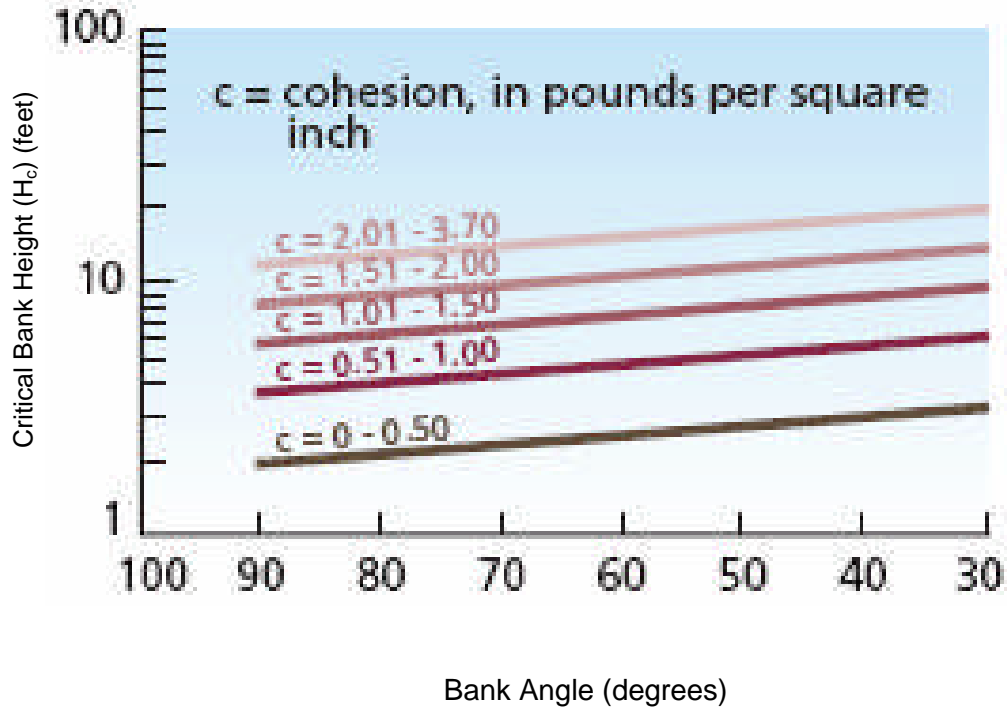

VERSION: April 30, 2009

REFERENCE:

FISRWG, 2001

FIGURE
808

WTC ENGINEERING, INC.

TYPICAL OPEN-CHANNEL DESIGN SECTIONS
(IMPROVED CHANNELS)

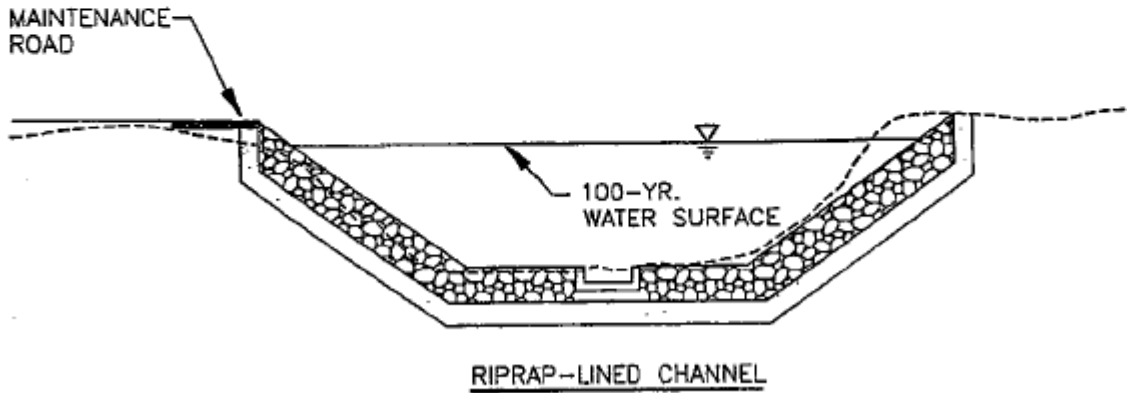
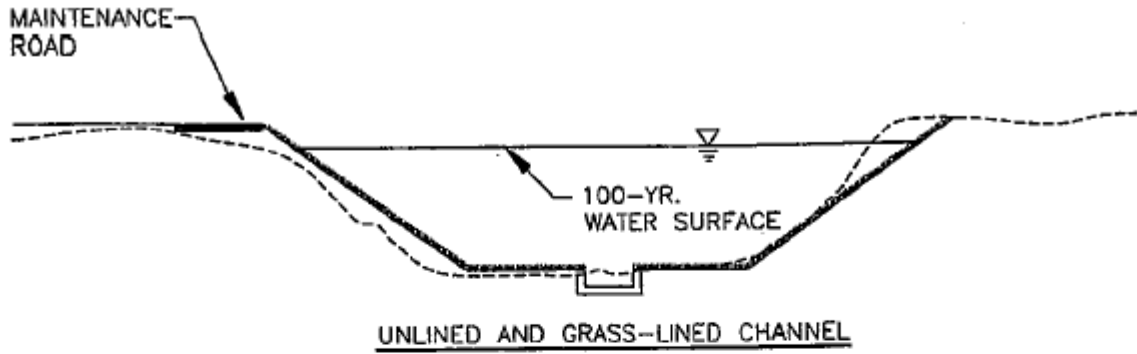

TYPICAL OPEN-CHANNEL DESIGN SECTIONS
(IMPROVED CHANNELS)

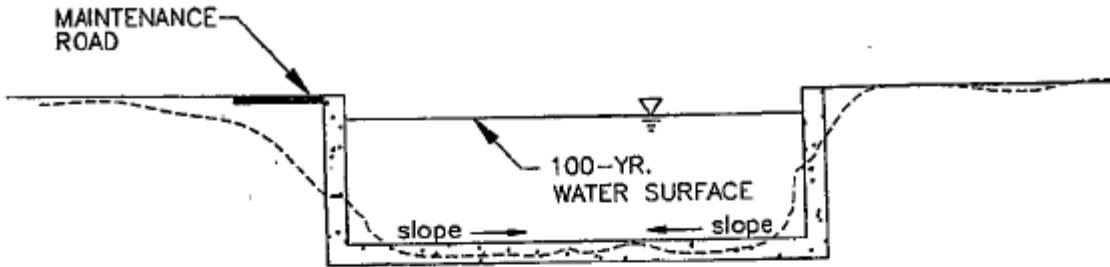

CONCRETE-LINED CHANNEL

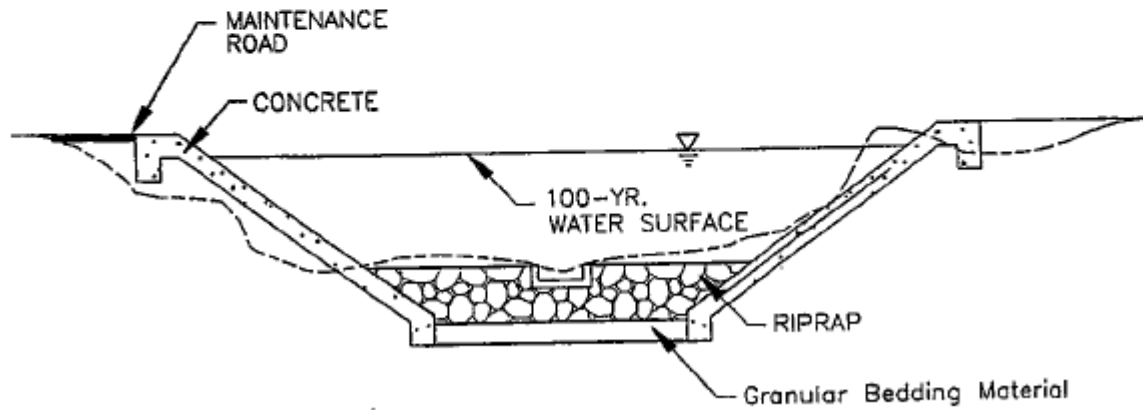

COMPOSITE-LINED CHANNEL

VERSION: April 30, 2009

REFERENCE:

FIGURE

809

2 of 2

W7C ENGINEERING, INC.

ROUGHNESS COEFFICIENT FOR GRASS-LINED CHANNELS

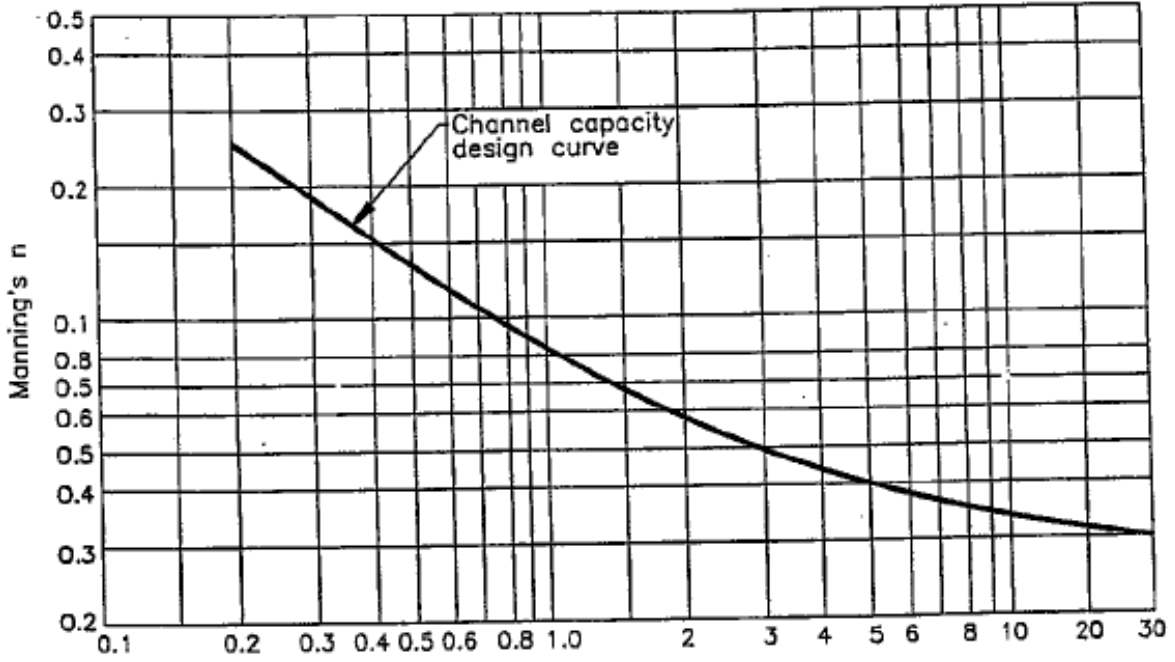

V*R
PRODUCT OF VELOCITY AND HYDRAULIC RADIUS

TYPICAL CROSS-SECTION OF CONCRETE-LINED LOW-FLOW CHANNEL

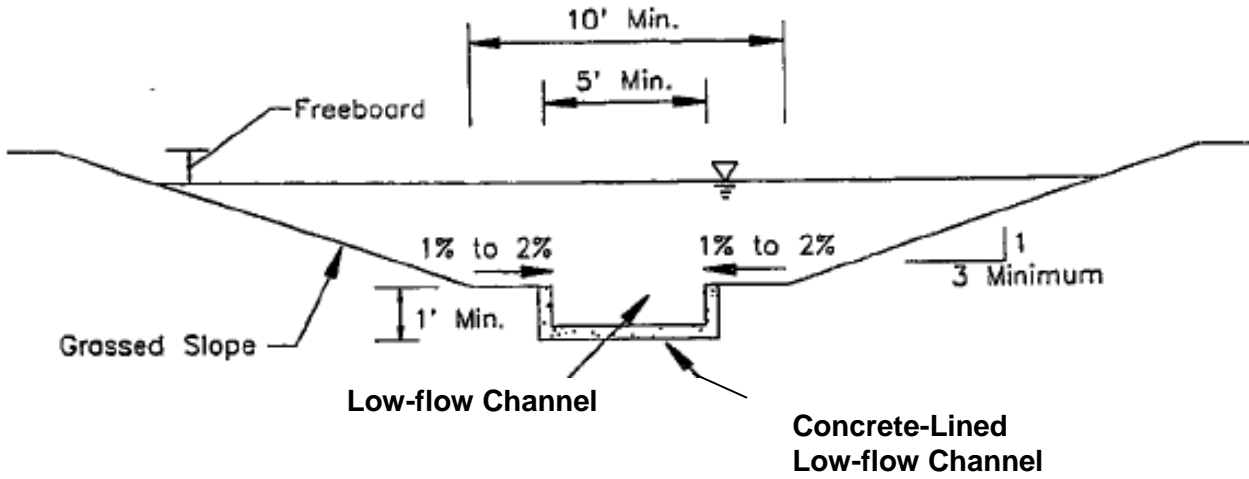

VERSION: April 30, 2009

REFERENCE:

FIGURE
811

WTC ENGINEERING, INC.

TYPICAL CROSS-SECTION OF RIPRAP-LINED LOW-FLOW CHANNEL

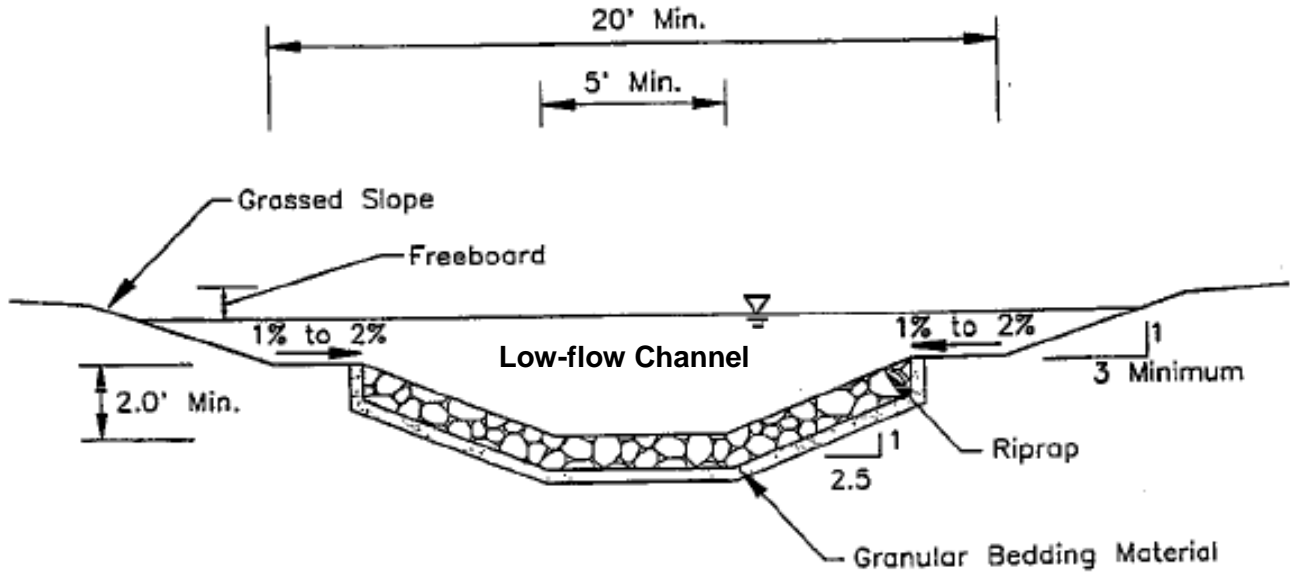

VERSION: April 30, 2009

REFERENCE:

FIGURE
812

WTC ENGINEERING, INC.

TYPICAL CROSS-SECTION OF LOW-FLOW CHANNEL

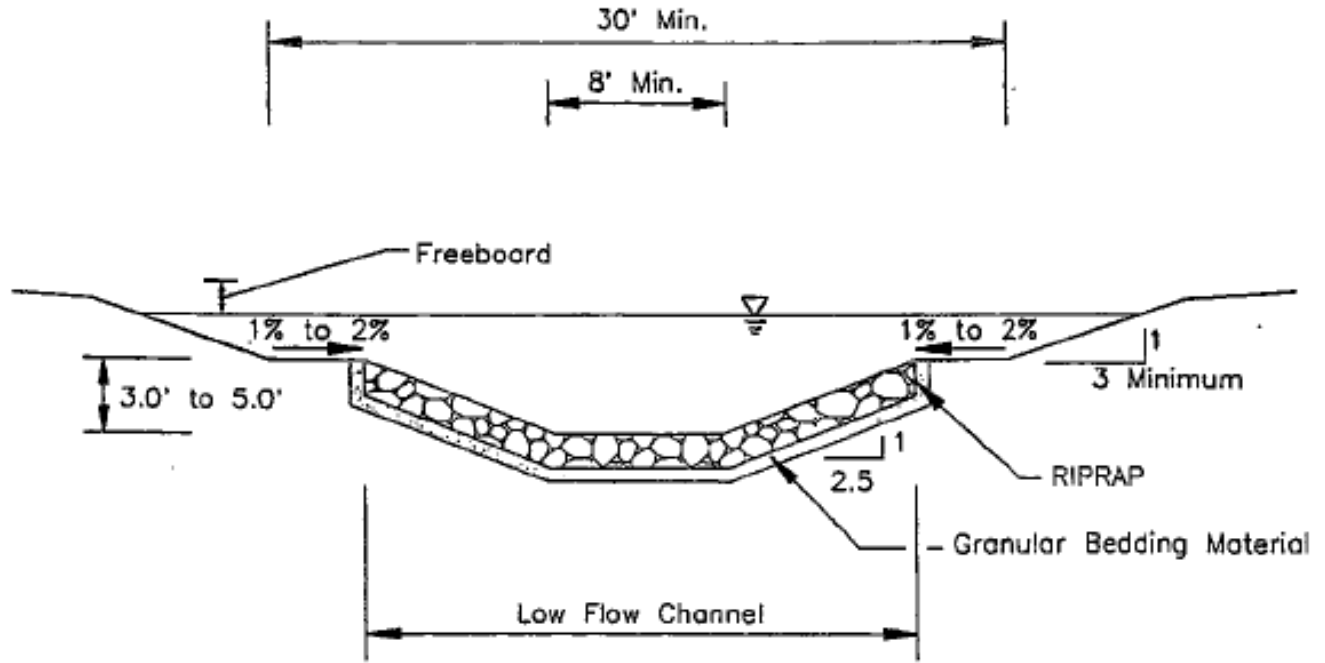

VERSION: April 30, 2009

REFERENCE:

FIGURE
813

WTC ENGINEERING, INC.

MANNINGS ROUGHNESS COEFFICIENT FOR WETLAND BOTTOM

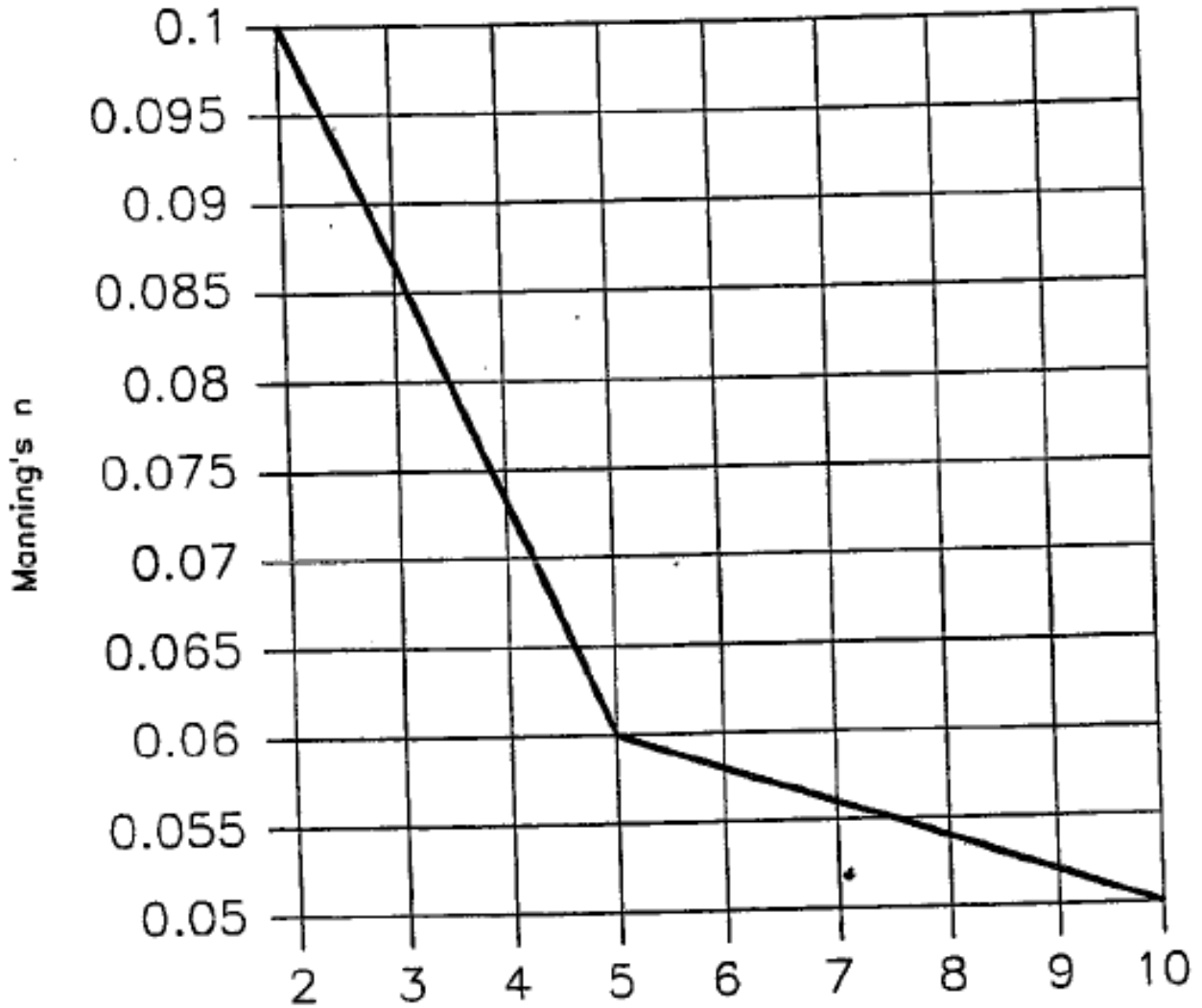

* Depth of Flow (Feet)

* Use normal depth, ignoring all backwater effects

VERSION: April 30, 2009

REFERENCE:

FIGURE
814

WTC ENGINEERING, INC.

TYPICAL CROSS-SECTIONS FOR RIPRAP-LINED CHANNELS

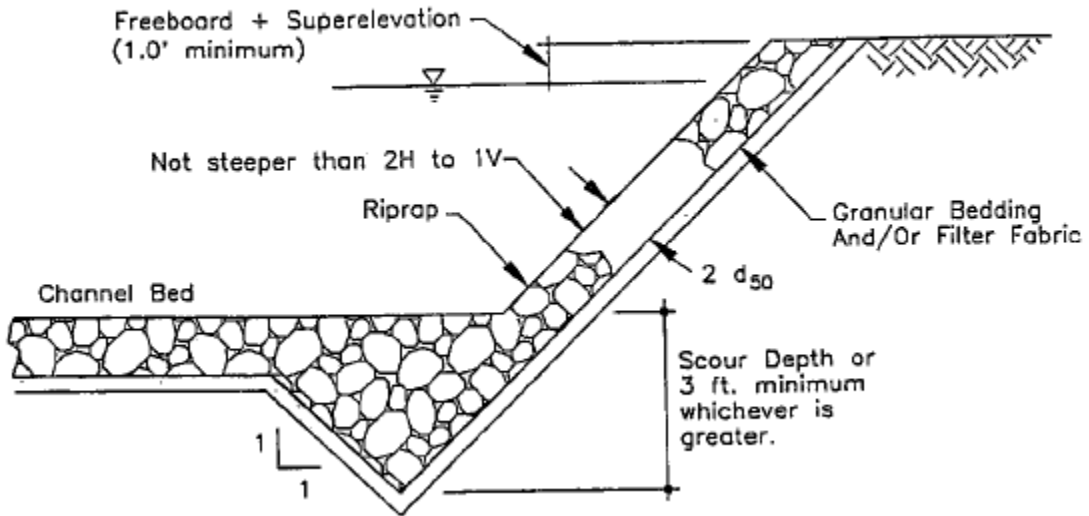
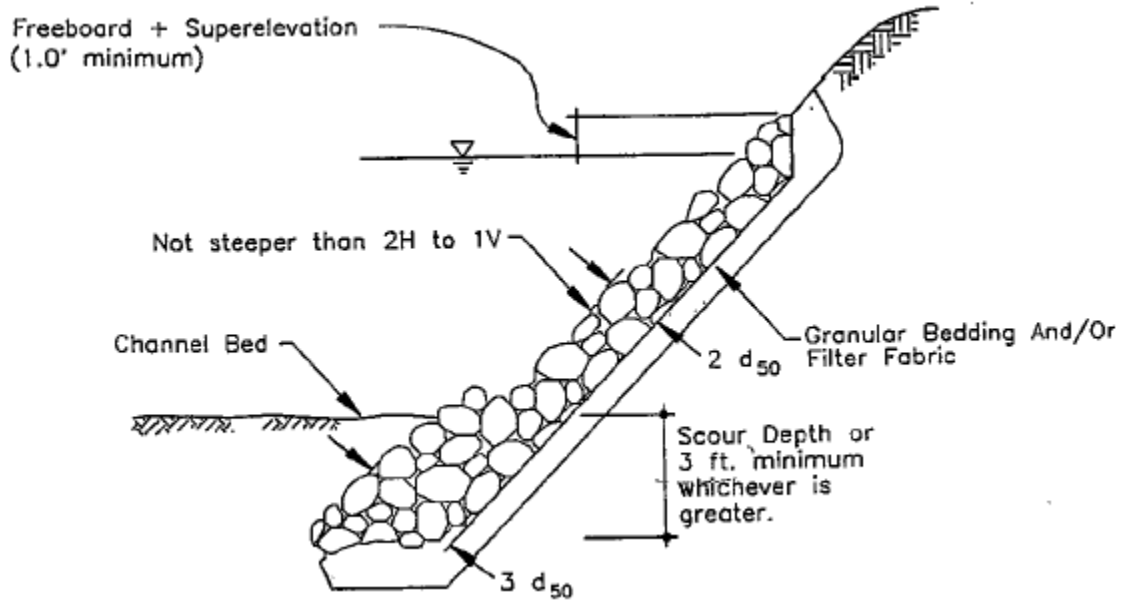

VERSION: April 30, 2009

REFERENCE:

FIGURE
815

WTC ENGINEERING, INC.

TYPICAL CROSS-SECTIONS FOR GROUTED RIPRAP LINING

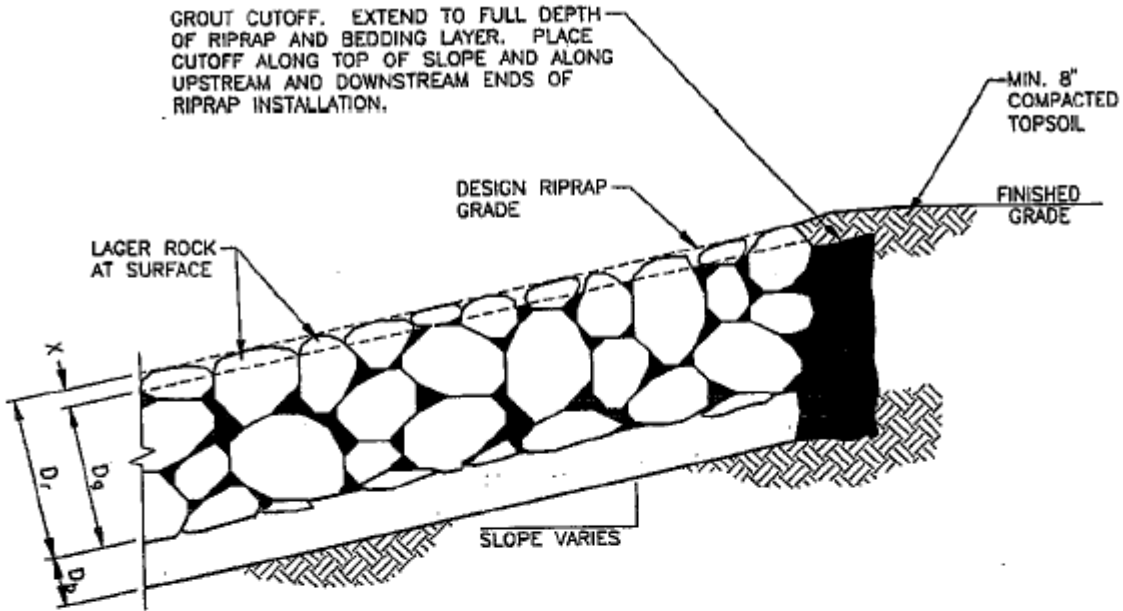

RIPRAP TYPE	D_r	X	D_g	D_b
MG	21	3 to 5	16 to 18	REFER TO MANUAL
HG	30	6 to 10	20 to 24	
VHG	42	8 to 12	30 to 34	

- D_b = DEPTH OF BEDDING MATERIAL
- D_g = DEPTH OF GROUT LAYER
- D_r = DEPTH OF RIPRAP LAYER
- X = DEPTH FROM RIPRAP SURFACE TO GROUT SURFACE

NOTES:

1. FINAL PLACEMENT OF RIPRAP TO BE APPROVED BY ENGINEER PRIOR TO GROUTING.
2. BEFORE GROUTING, CLEAN ALL DIRT AND MATERIALS FROM ROCK THAT COULD PREVENT THE GROUT FROM BONDING TO ROCK.
3. PLACE GROUT BY INJECTION METHODS AND USE A PENCIL VIBRATOR TO FILL VOIDS TO THE SPECIFIED GROUT DEPTH. CLEAN EXCESS GROUT FROM ALL EXPOSED SURFACES. PROVIDE A BROOM FINISH FOR GROUT SURFACE.
4. THE CONTRACTOR SHALL CONTROL GROUT MIX AND PLACEMENT PROCEDURES TO ACHIEVE THE SPECIFIED THICKNESS, PENETRATION AND GRADE OF THE GROUT LAYER.

VERSION: April 30, 2009

REFERENCE:

FIGURE

WTC ENGINEERING, INC.

816

OPTIMUM RIPRAP SIDE SLOPE FOR A GIVEN SIZE RIPRAP

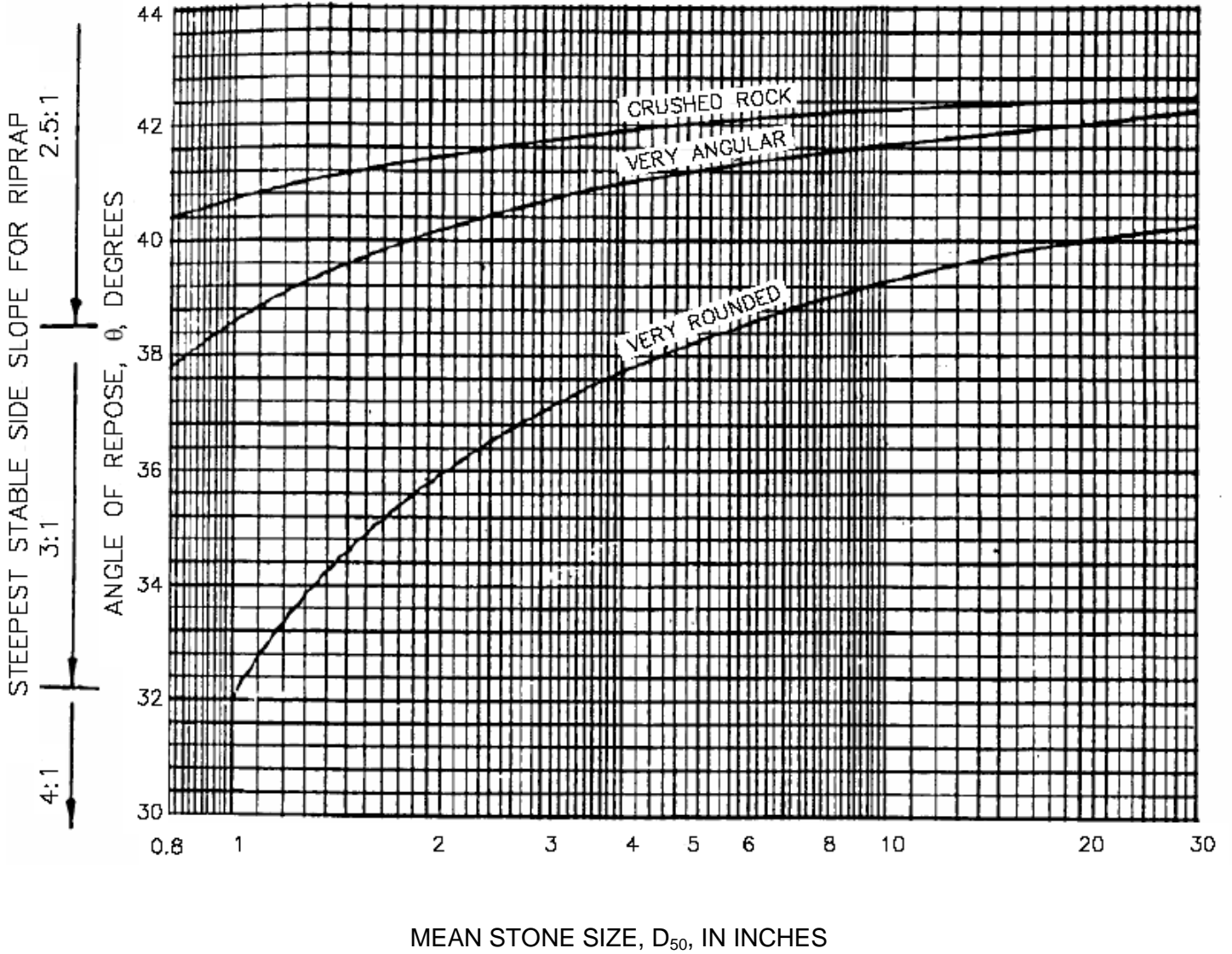

VERSION: April 30, 2009

REFERENCE:
SCS, 1989

FIGURE
818A

WTC ENGINEERING, INC.

RIPRAP END PROTECTION

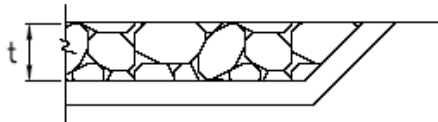
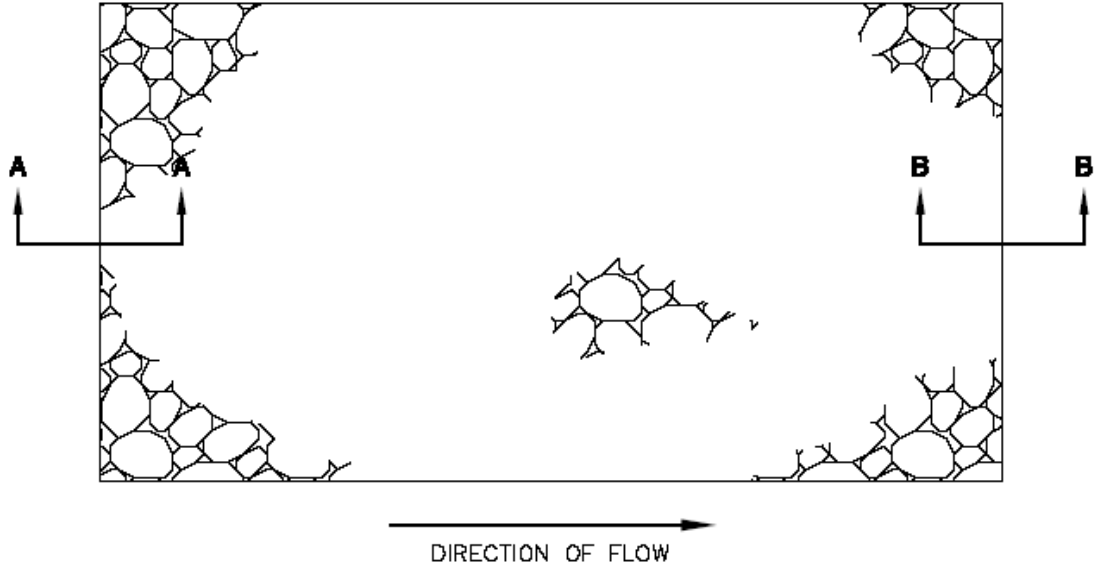

METHOD A

NOTES:

1. USE METHOD B AT SECTION A-A (UPSTREAM EDGE).
2. EITHER METHOD A OR METHOD B MAY BE USED AT THE DOWNSTREAM EDGE (SECTION B-B).
3. t IS THE THICKNESS OF THE RIPRAP LAYER.

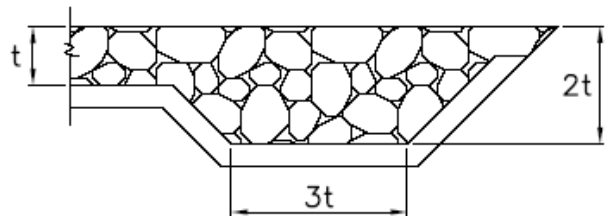

METHOD B

LEGEND



RIPRAP

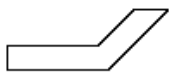

FILTER LAYER
AS REQUIRED

VERSION: April 30, 2009

REFERENCE:

Blodgett, 1986

FIGURE
818B

WTC ENGINEERING, INC.

TOE PROTECTION ALTERNATIVES

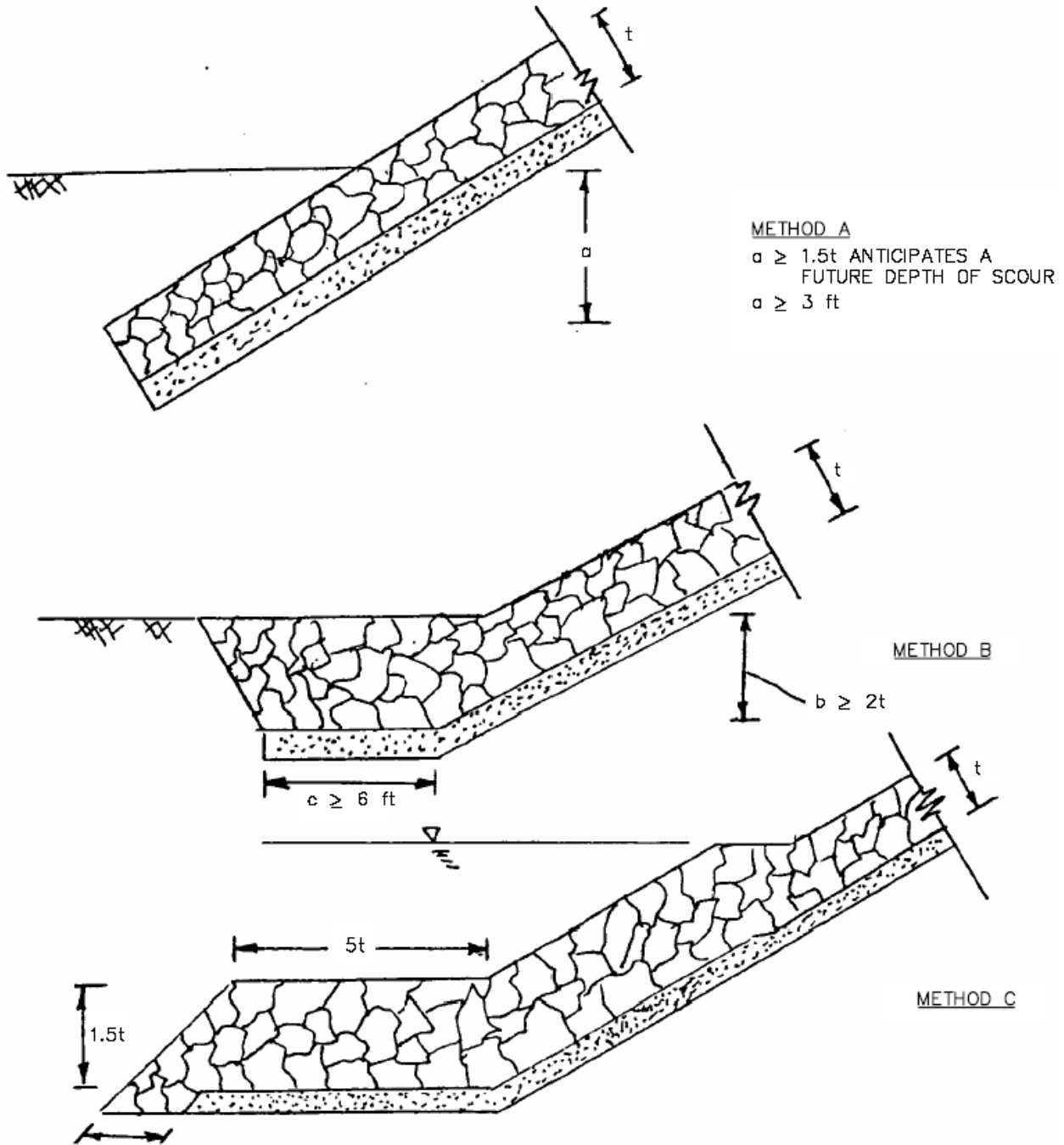

VERSION: April 30, 2009

REFERENCE:

Blodgett, 1986

FIGURE
818C

WTC ENGINEERING, INC.

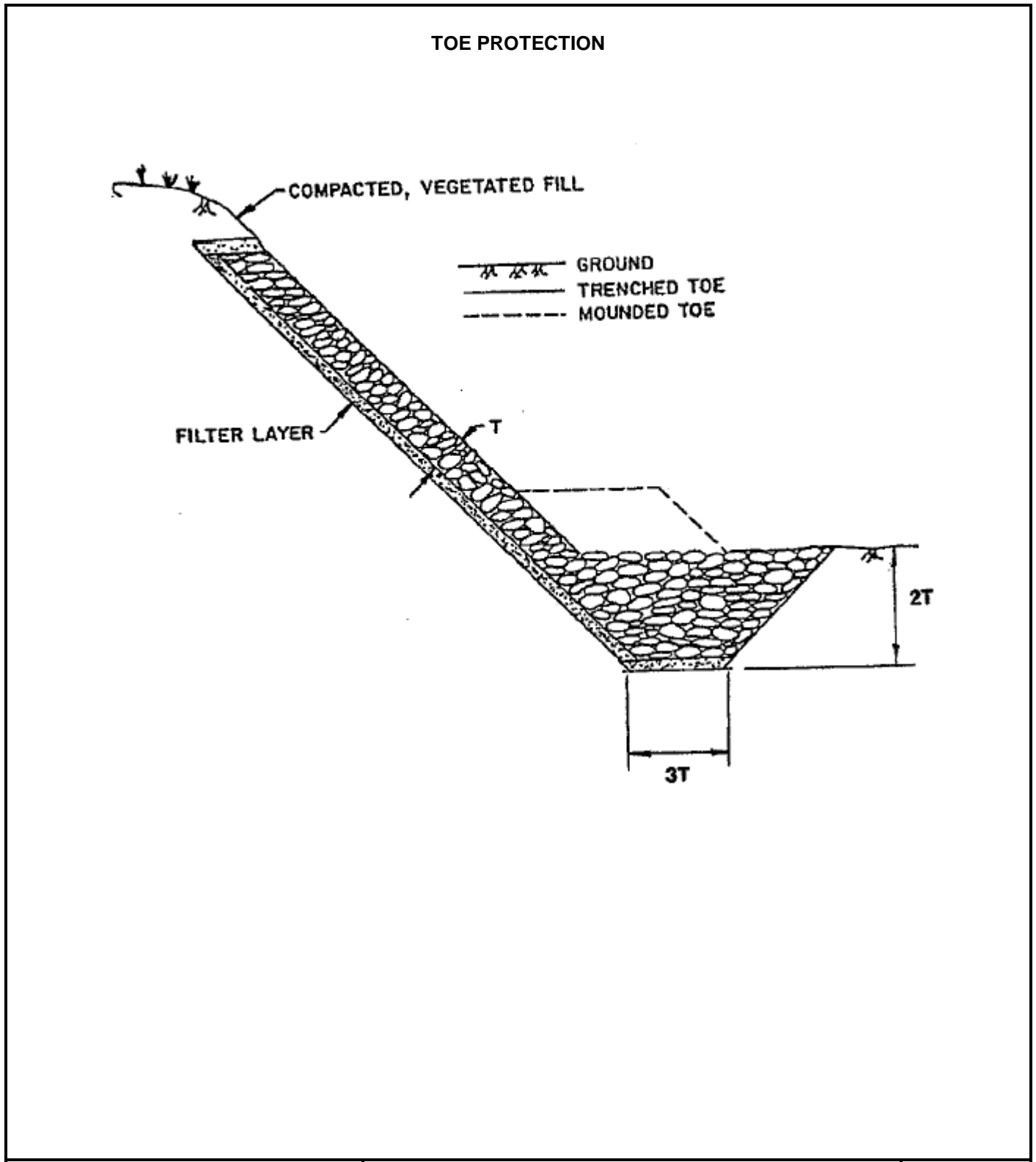

VERSION: April 30, 2009

REFERENCE:

Blodgett, 1986

FIGURE
818D

WTC ENGINEERING, INC.

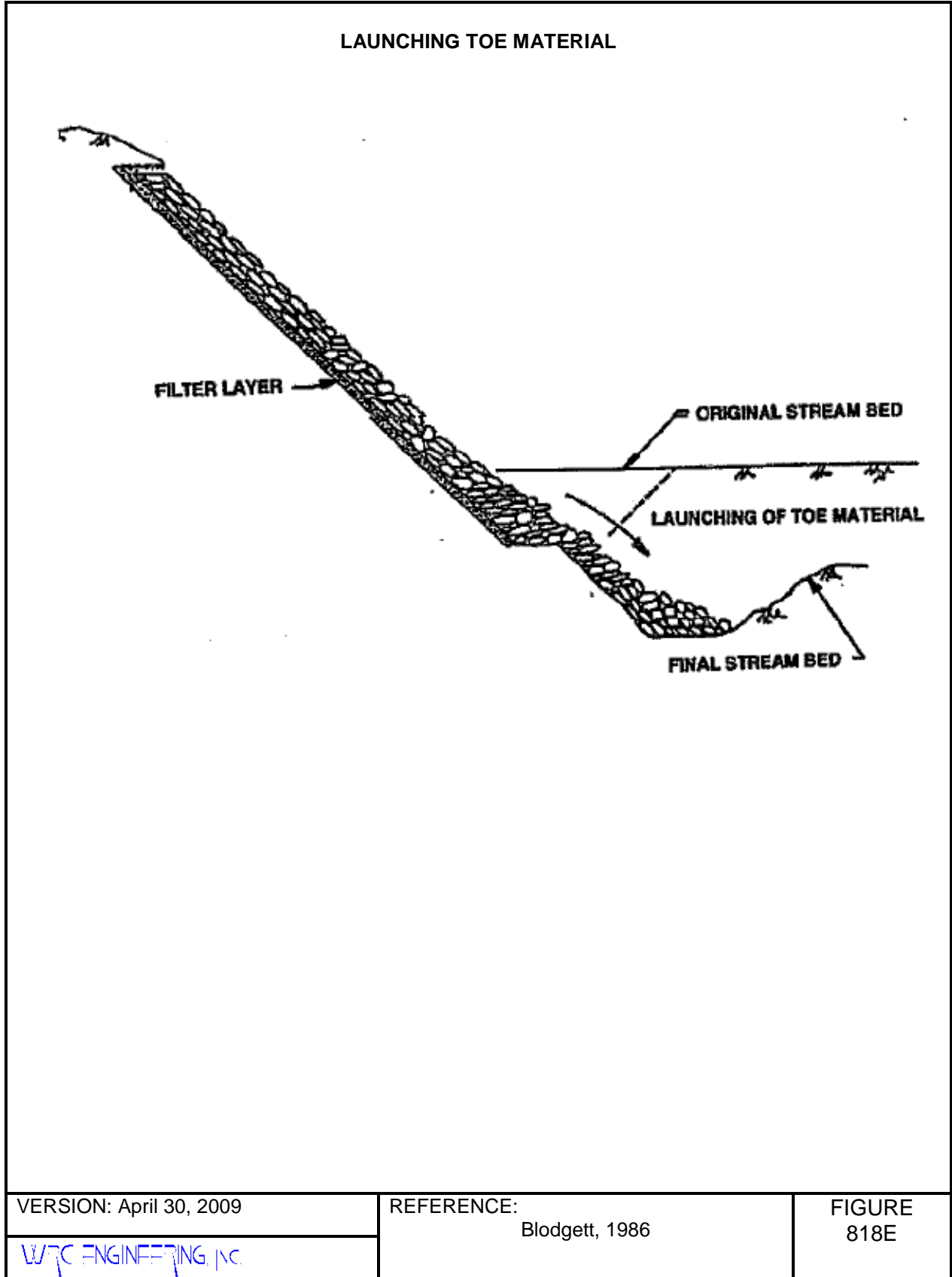

"DUTCH" TOE

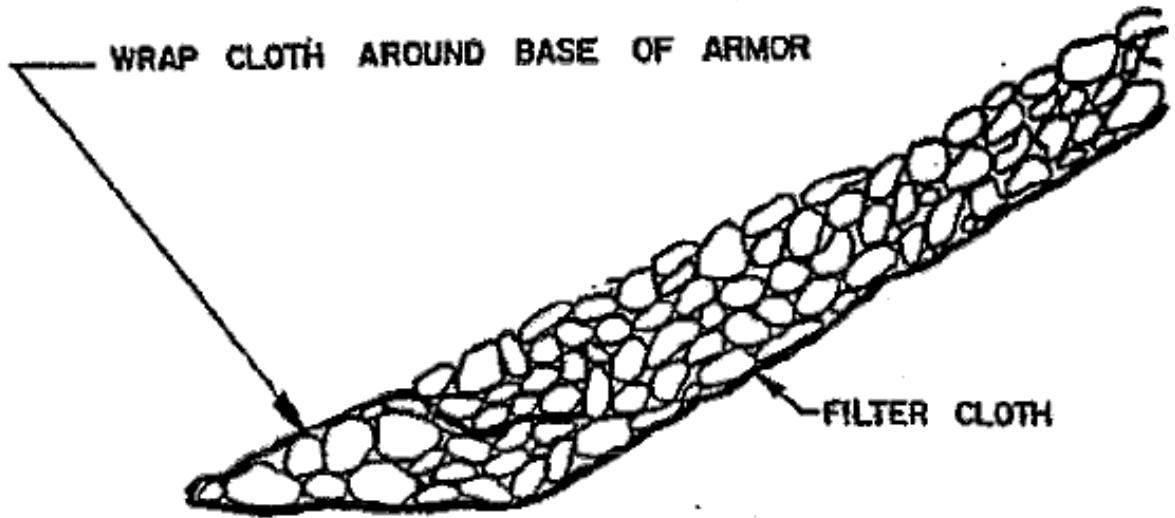

VERSION: April 30, 2009

REFERENCE:

Blodgett, 1986

FIGURE
818F

WJC ENGINEERING, INC.

**STEEP SLOPE RIPRAP DESIGN,
TRIANGULAR CHANNELS, 2:1 SIDESLOPES**

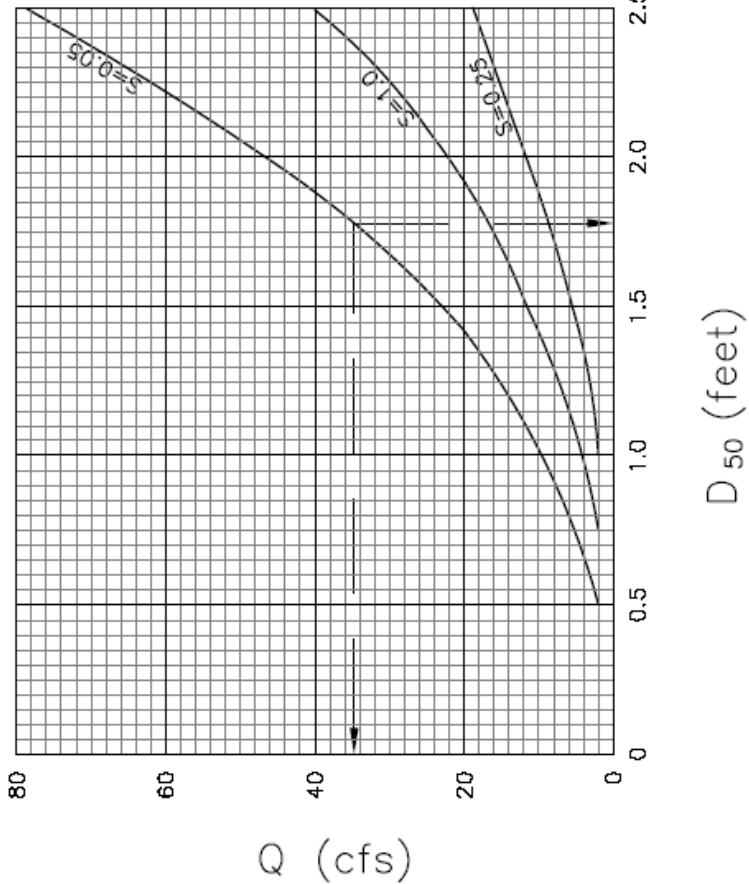
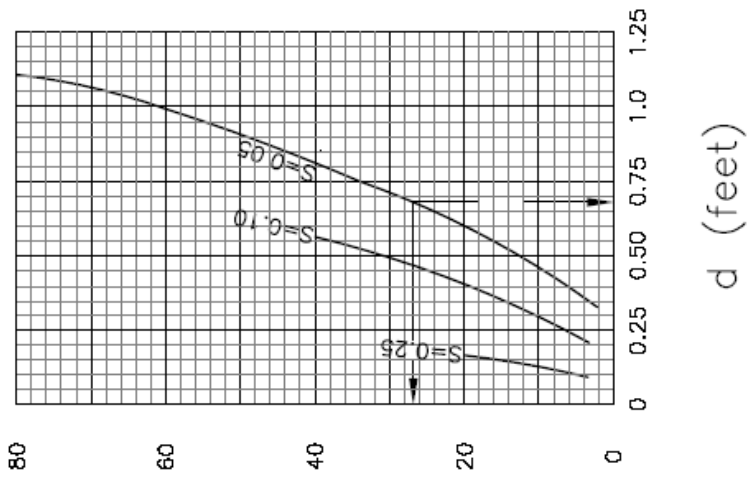

VERSION: April 30, 2009

REFERENCE:
Simons, Li and Associates, 1989

FIGURE
819

WJC ENGINEERING, INC.

**STEEP SLOPE RIPRAP DESIGN,
TRAPEZOIDAL CHANNELS, 2:1 SIDESLOPES, 6 FOOT BASE WIDTH**

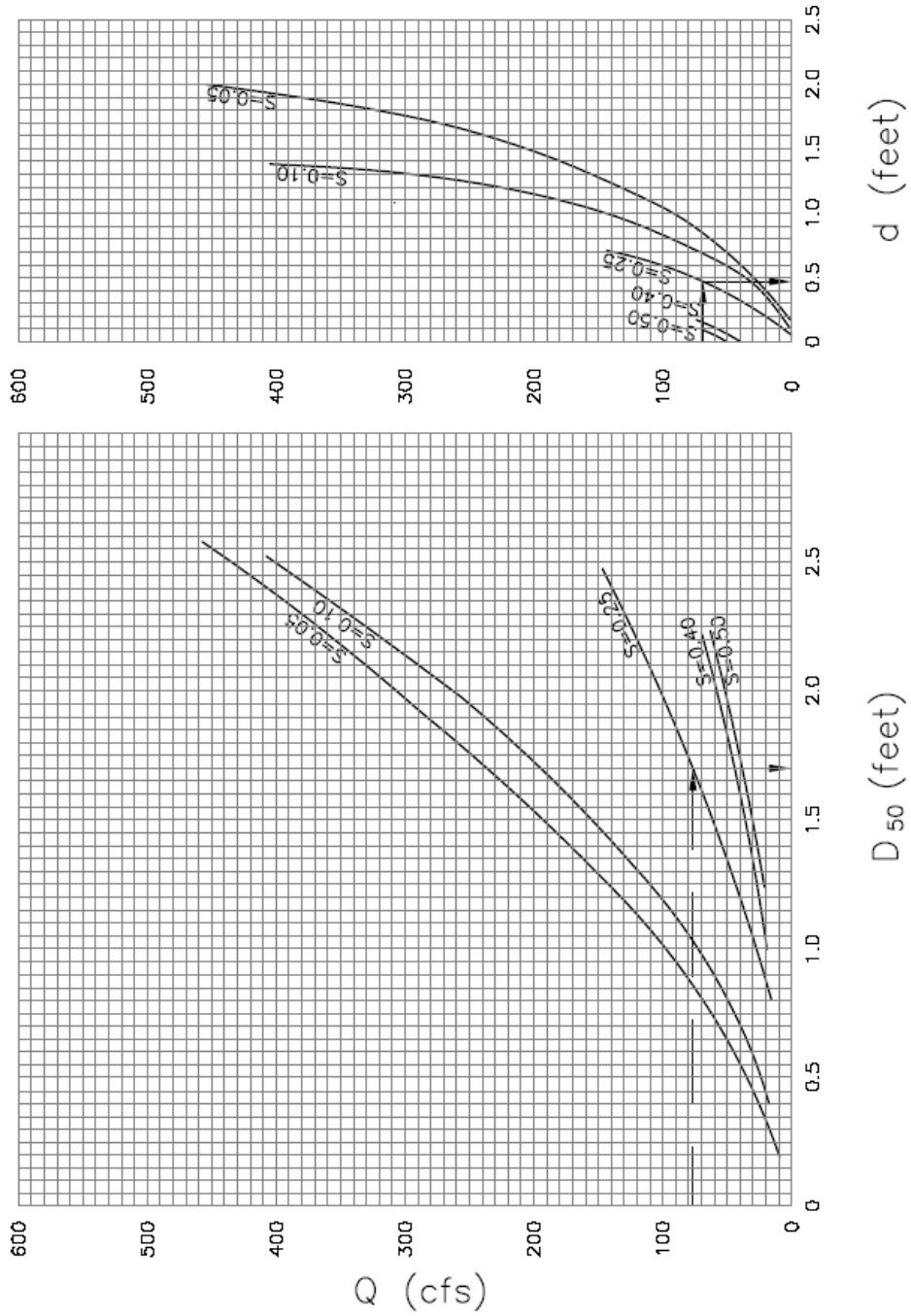

VERSION: April 30, 2009

REFERENCE:
 Simons, Li and Associates, 1989

FIGURE
 820

WJC ENGINEERING, INC.

**STEEP SLOPE RIPRAP DESIGN,
TRAPEZOIDAL CHANNELS, 2:1 SIDESLOPES, 10 FOOT BASE WIDTH**

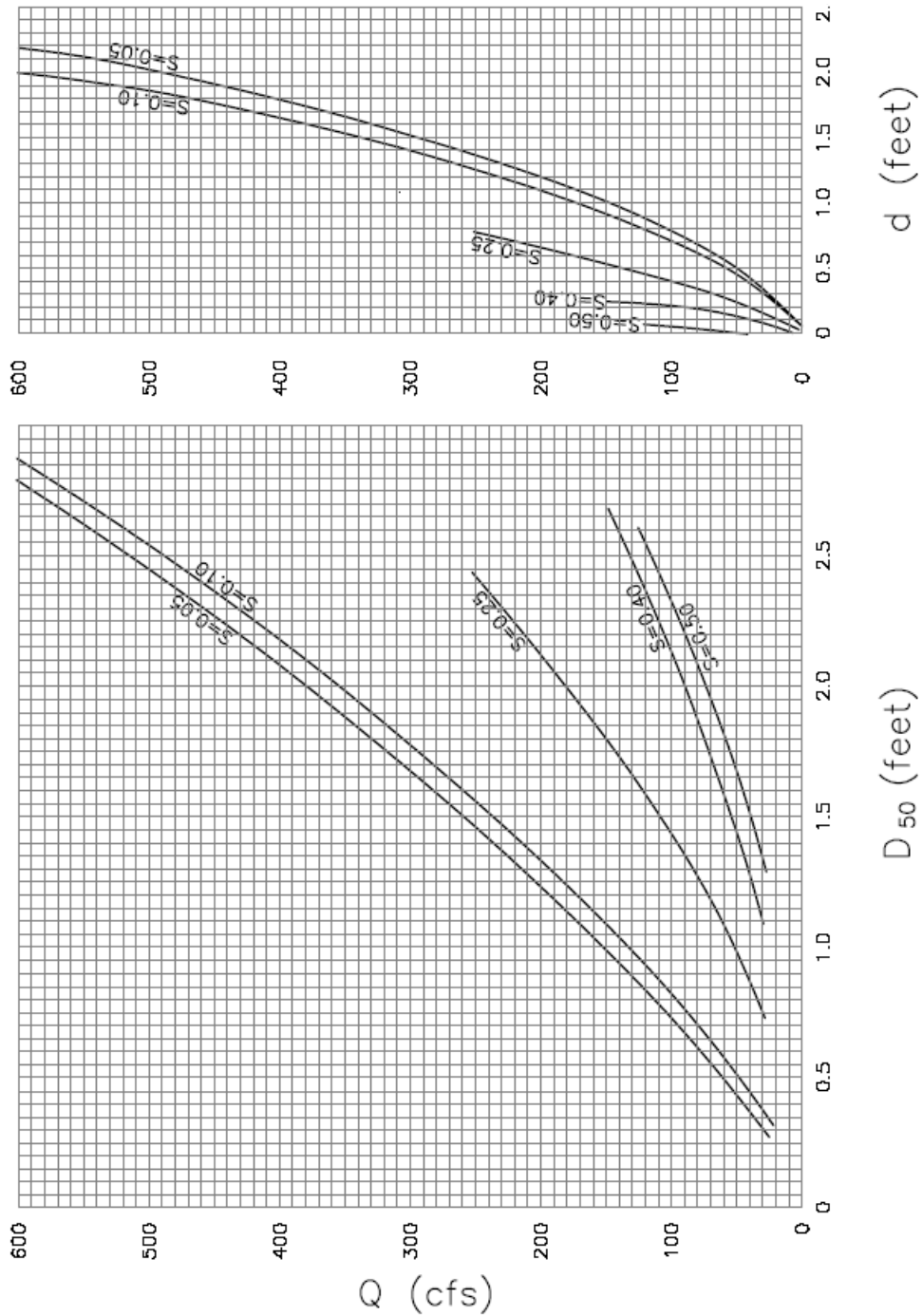

VERSION: April 30, 2009

WJC ENGINEERING, INC.

REFERENCE:

Simons, Li and Associates, 1989

FIGURE

821

**STEEP SLOPE RIPRAP DESIGN,
TRAPEZOIDAL CHANNELS, 2:1 SIDESLOPES, 14 FOOT BASE WIDTH**

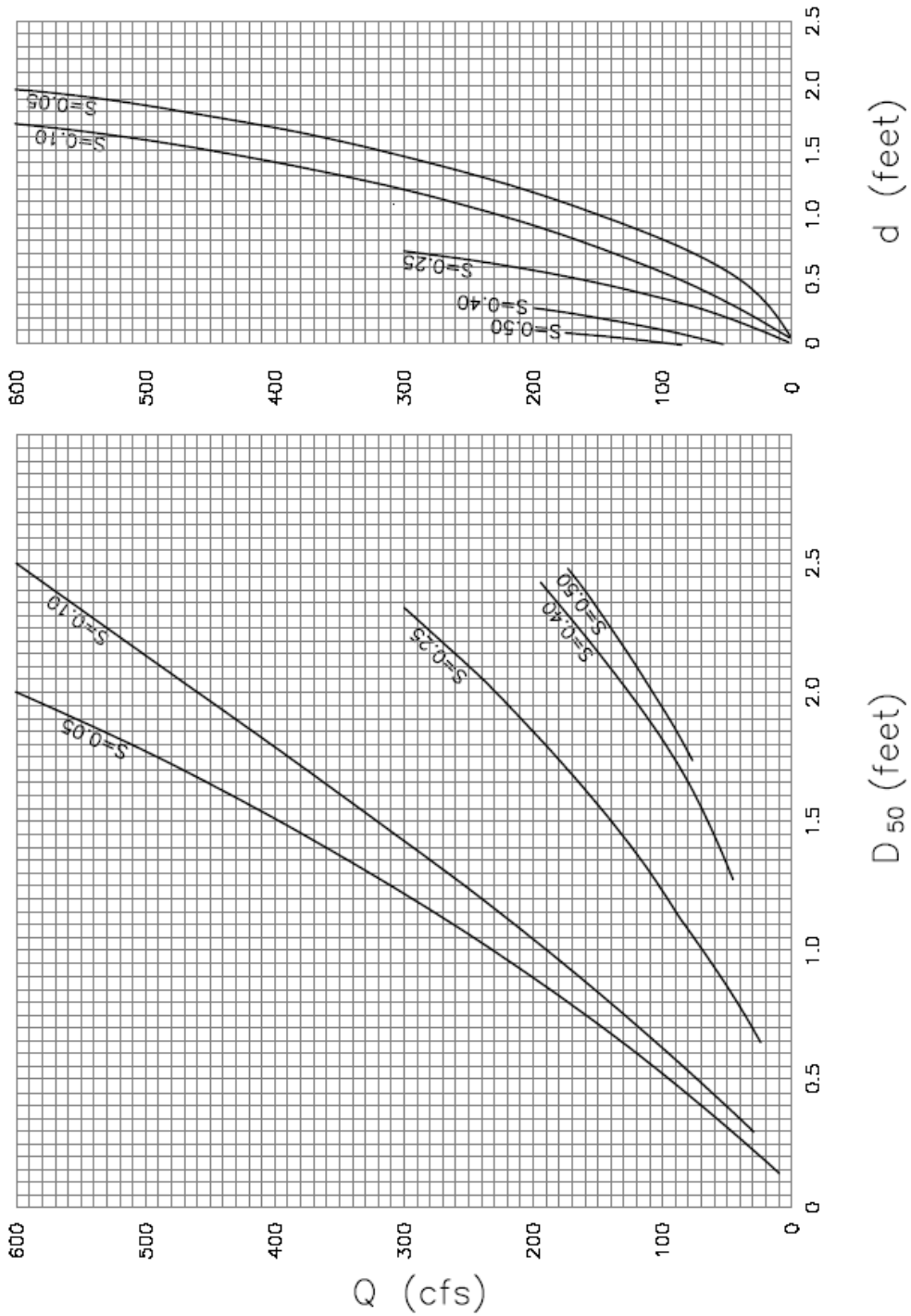

VERSION: April 30, 2009

REFERENCE:

Simons, Li and Associates, 1989

FIGURE
822

WJC ENGINEERING, INC.

**STEEP SLOPE RIPRAP DESIGN,
TRAPEZOIDAL CHANNELS, 2:1 SIDESLOPES, 20 FOOT BASE WIDTH**

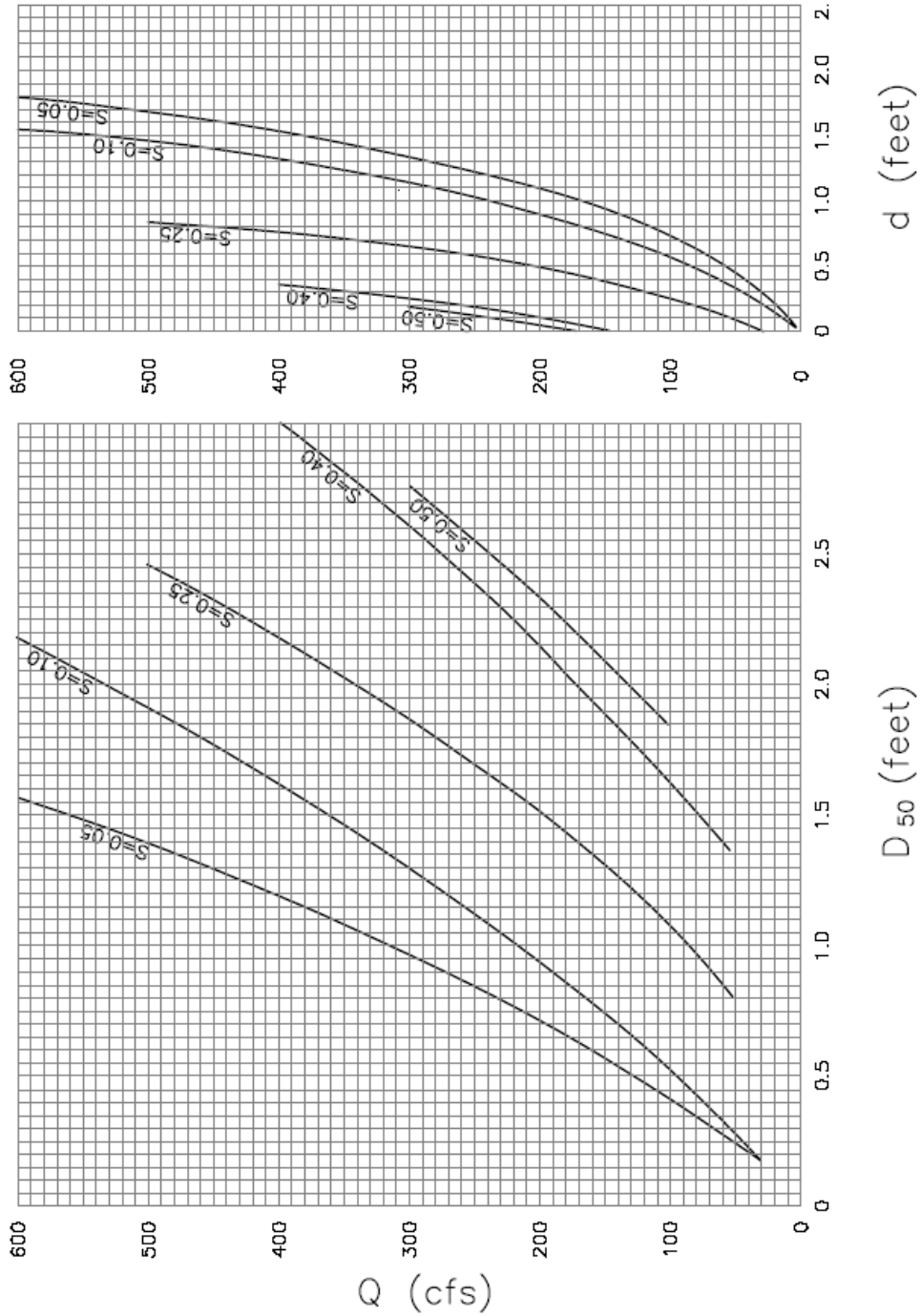

VERSION: April 30, 2009

REFERENCE:
Simons, Li and Associates, 1989

FIGURE
823

WTC ENGINEERING, INC.

SLOPE GABION MATTRESS LINING

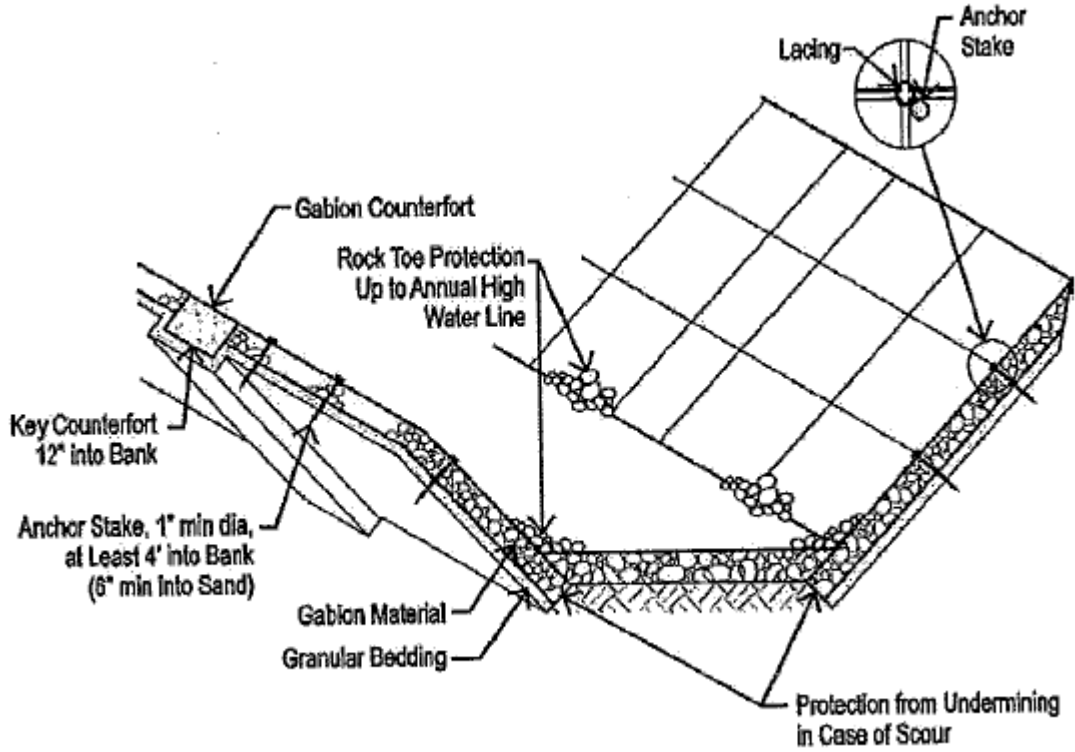

VERSION: April 30, 2009

REFERENCE:
Wright-McLaughlin Engineers, 1969

FIGURE
824

WTC ENGINEERING, INC.

CHANNEL TRANSITION TYPES

$$\text{Froude Number} = \sqrt{\frac{V_A}{gY_A}}$$

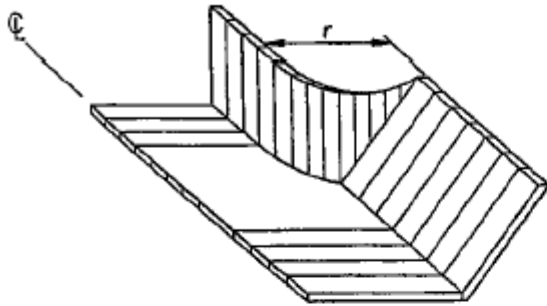

CYLINDRICAL QUADRANT

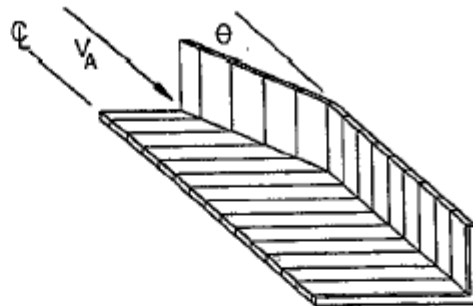

STRAIGHT LINE

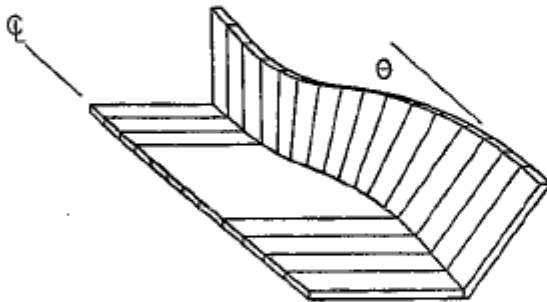

WARPED

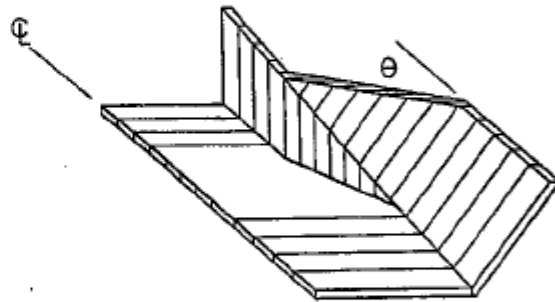

WEDGE

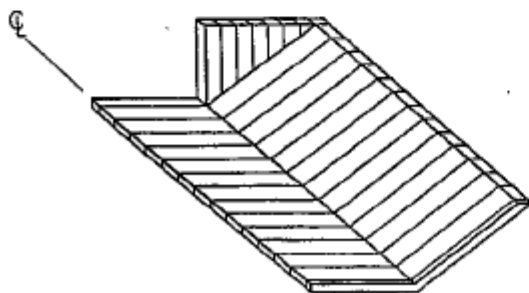

SQUARE-ENDED

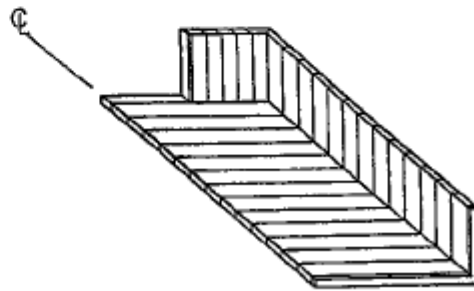

SQUARE-ENDED

VERSION: April 30, 2009

REFERENCE:

FIGURE
825

WTC ENGINEERING, INC.

TYPICAL CHANNEL TRANSITION SECTIONS
AND ENERGY LOSS COEFFICIENTS

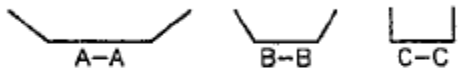
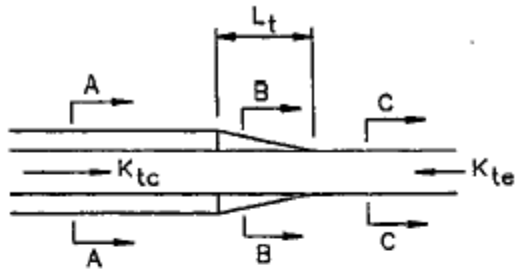

WARPED TRANSITION
 K_{tc} (CONTRACTION)=0.1
 K_{te} (EXPANSION)=0.2

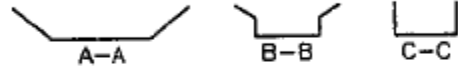
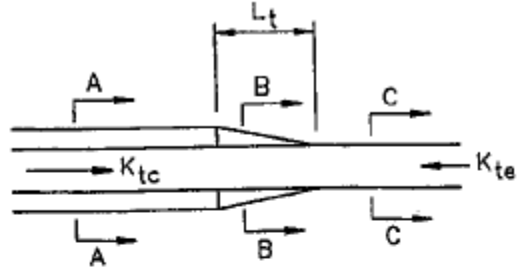

STRAIGHT-LINE TRANSITION
 K_{tc} (CONTRACTION)=0.3
 K_{te} (EXPANSION)=0.5

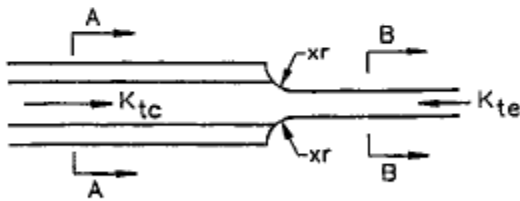

CYLINDER-QUADRANT
 $K_{tc} = 0.15$
 $K_{te} = 0.25$

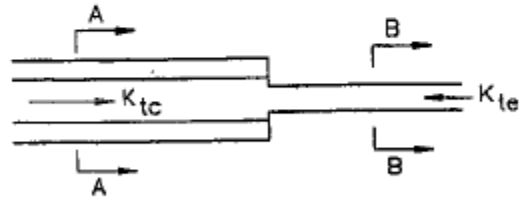

SQUARE-ENDED TRANSITION
 $K_{tc} = 0.30$
 $K_{te} = 0.75$

TYPICAL CONTRACTING TRANSITION FOR SUPERCRITICAL FLOW

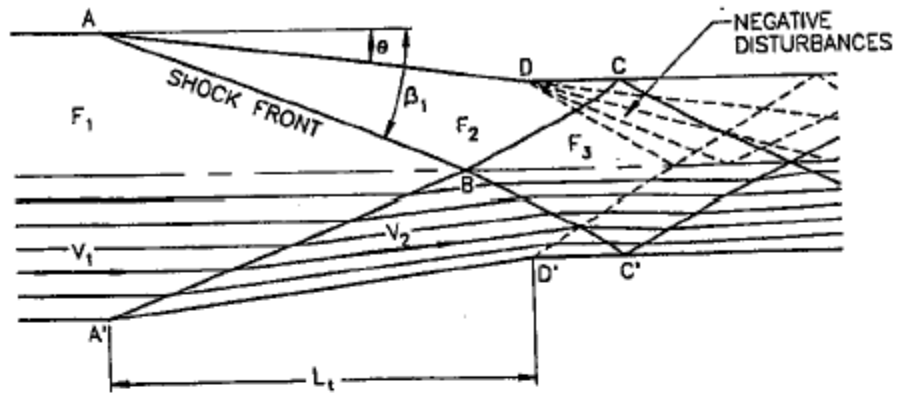

(a)

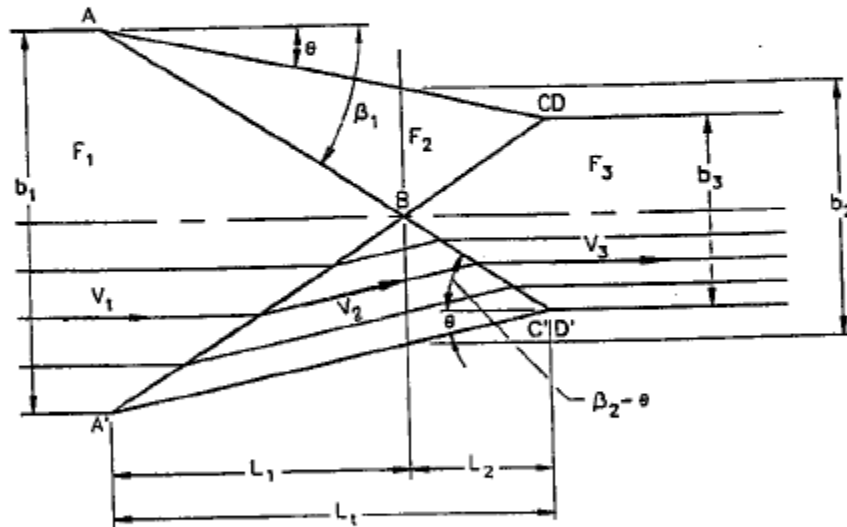

(b)

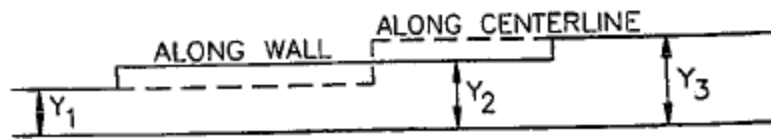

(c)

NOTES:

- (a) General disturbance patterns
- (b) Minimum downstream disturbance
- (c) Schematic profile

VERSION: April 30, 2009

REFERENCE:

Chow, V.T., *Open-Channel Hydraulics*, 1959

FIGURE

827

WTC ENGINEERING, INC.

DESIGN CHART FOR CONTRACTING TRANSITION FOR SUPERCRITICAL FLOW

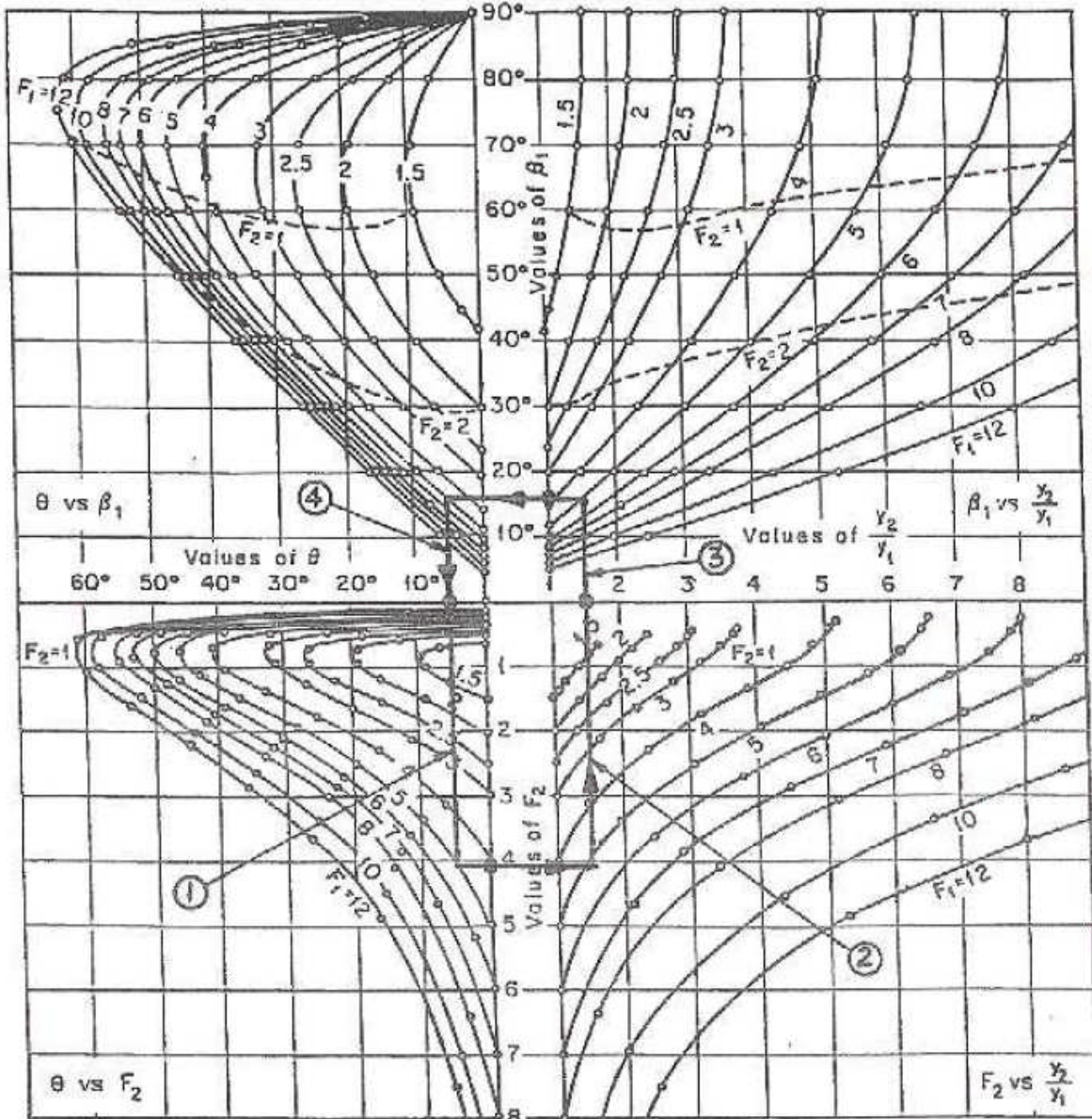

EXAMPLE: For $\theta = 5^\circ$ and $F_1 = 5.0$

- ① Read $F_2 = 4.1$
- ② Read $y_2/y_1 = 1.5$
- ③ Read $\beta_1 = 16^\circ$
- ④ Read $\theta = 5^\circ$ (check)

VERSION: April 30, 2009

WTC ENGINEERING, INC.

REFERENCE:

Chow, V.T., *Open-Channel Hydraulics*, 1959

FIGURE

828

CONFIGURATION OF CULVERT OUTLET PROTECTION

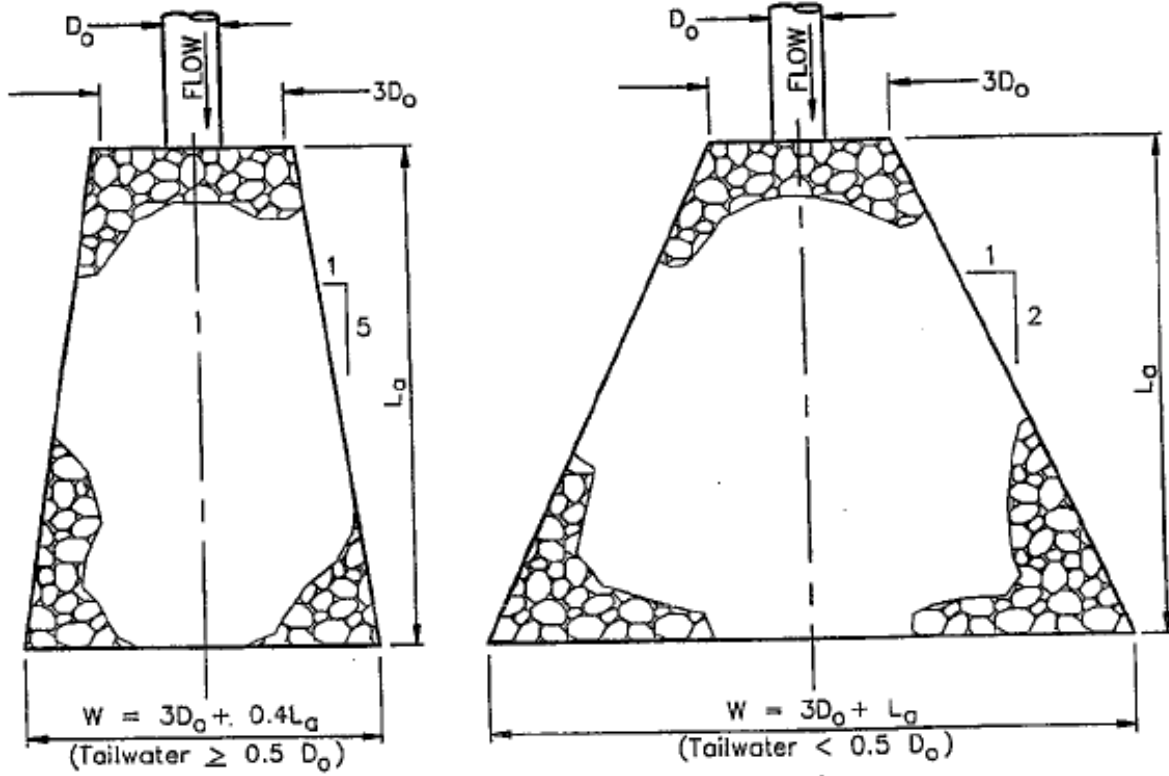

VERSION: April 30, 2009

REFERENCE:

U.S. EPA, 1976

FIGURE

829

WJC ENGINEERING, INC.

PRE-FORMED SCOUR HOLE

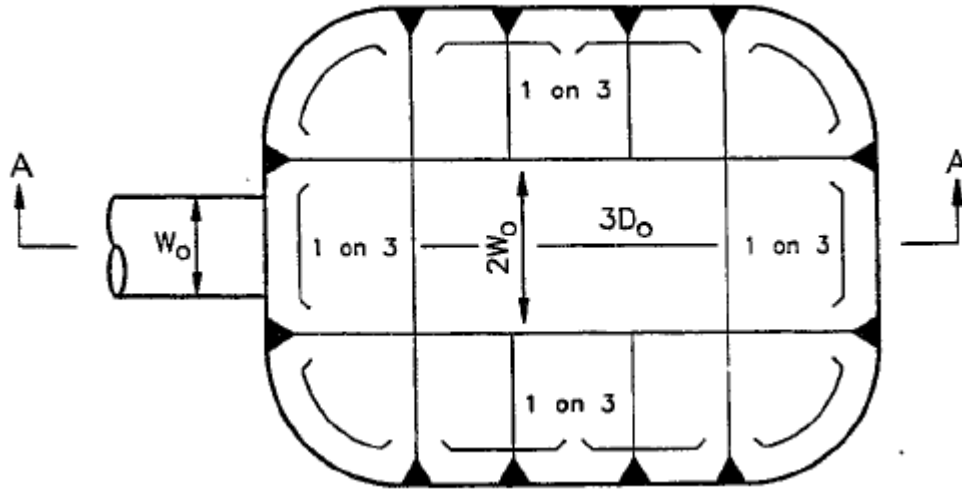

PLAN VIEW

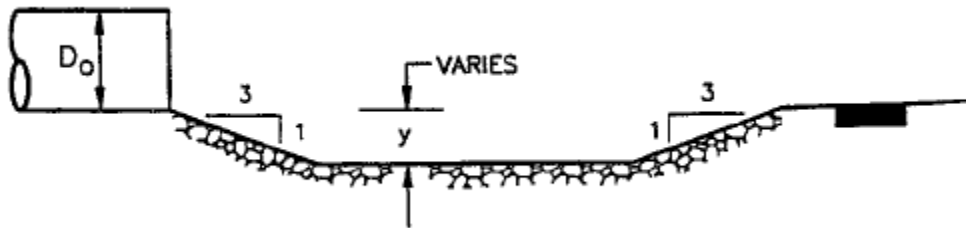

SECTION VIEW

VERSION: April 30, 2009

REFERENCE:

American Society of Civil Engineers, 1975

FIGURE
830

WTC ENGINEERING, INC.

SPACING OF GRADE CONTROL STRUCTURE

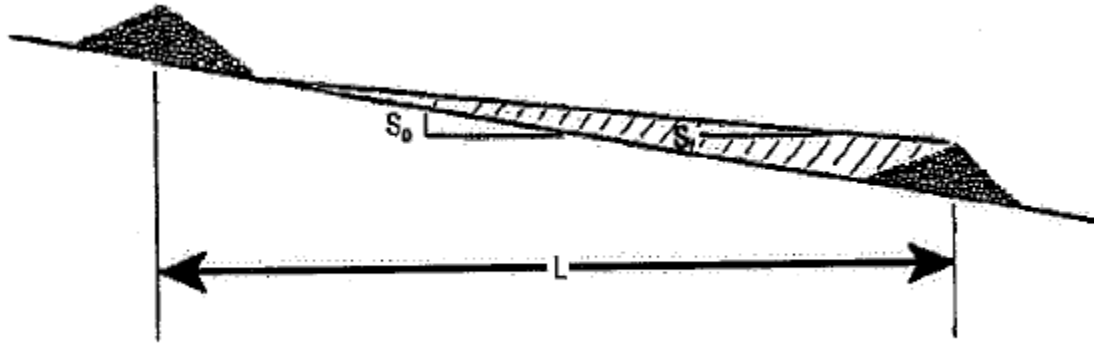

VERSION: April 30, 2009

REFERENCE:

Mussetter, 1982

FIGURE
831

WTC ENGINEERING, INC.

AS-BUILT RIPRAP GRADE CONTROL STRUCTURE WITH SUFFICIENT LAUNCH
STONE TO HANDLE ANTICIPATED SCOUR

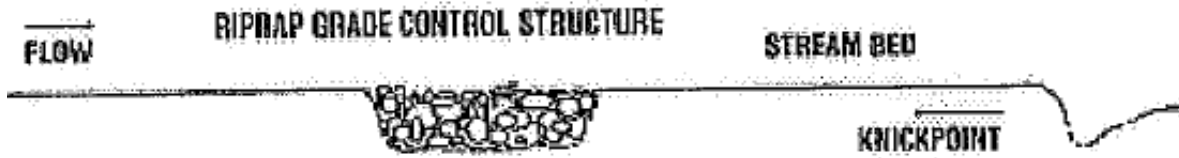

VERSION: April 30, 2009

REFERENCE:

FIGURE
832A

WTC ENGINEERING, INC.

LAUNCHING OF RIPRAP AT GRADE CONTROL STRUCTURE IN RESPONSE TO BED DEGRADATION AND LOCAL SCOUR



VERSION: April 30, 2009

REFERENCE:

FIGURE
832B

WTC ENGINEERING, INC.

AS-BUILT RIPRAP GRADE CONTROL STRUCTURE WITH IMPERVIOUS FILL CUTOFF WALL

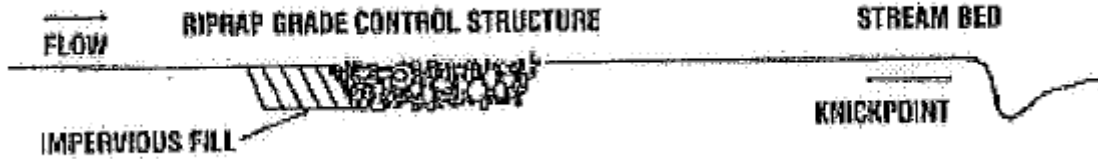

VERSION: April 30, 2009

REFERENCE:

FIGURE
833A

WTC ENGINEERING, INC.

LAUNCHING OF RIPRAP AT GRADE CONTROL STRUCTURE IN RESPONSE TO BED DEGRADATION AND LOCAL SCOUR



VERSION: April 30, 2009

REFERENCE:

FIGURE
833B

WTC ENGINEERING, INC.

AS-BUILT RIPRAP GRADE CONTROL STRUCTURE WITH SHEET PILE CUTOFF WALL

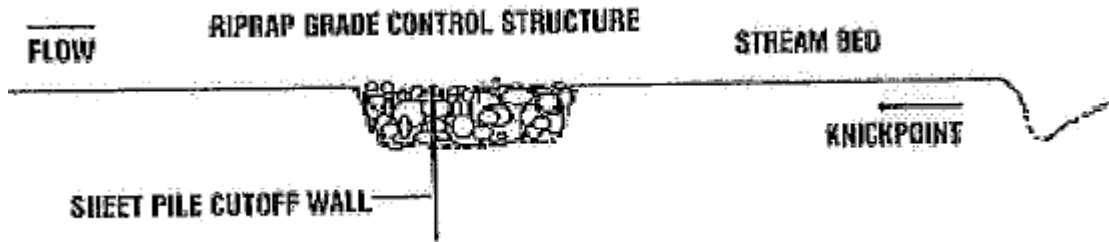

VERSION: April 30, 2009

REFERENCE:

FIGURE
834A

WJC ENGINEERING, INC.

LAUNCHING OF RIPRAP AT GRADE CONTROL STRUCTURE IN RESPONSE TO BED DEGRADATION AND LOCAL SCOUR



VERSION: April 30, 2009

REFERENCE:

FIGURE
834B

WTC ENGINEERING, INC.

SLOPING DROP GRADE CONTROL STRUCTURE WITH PRE-FORMED RIPRAP LINED SCOUR HOLE

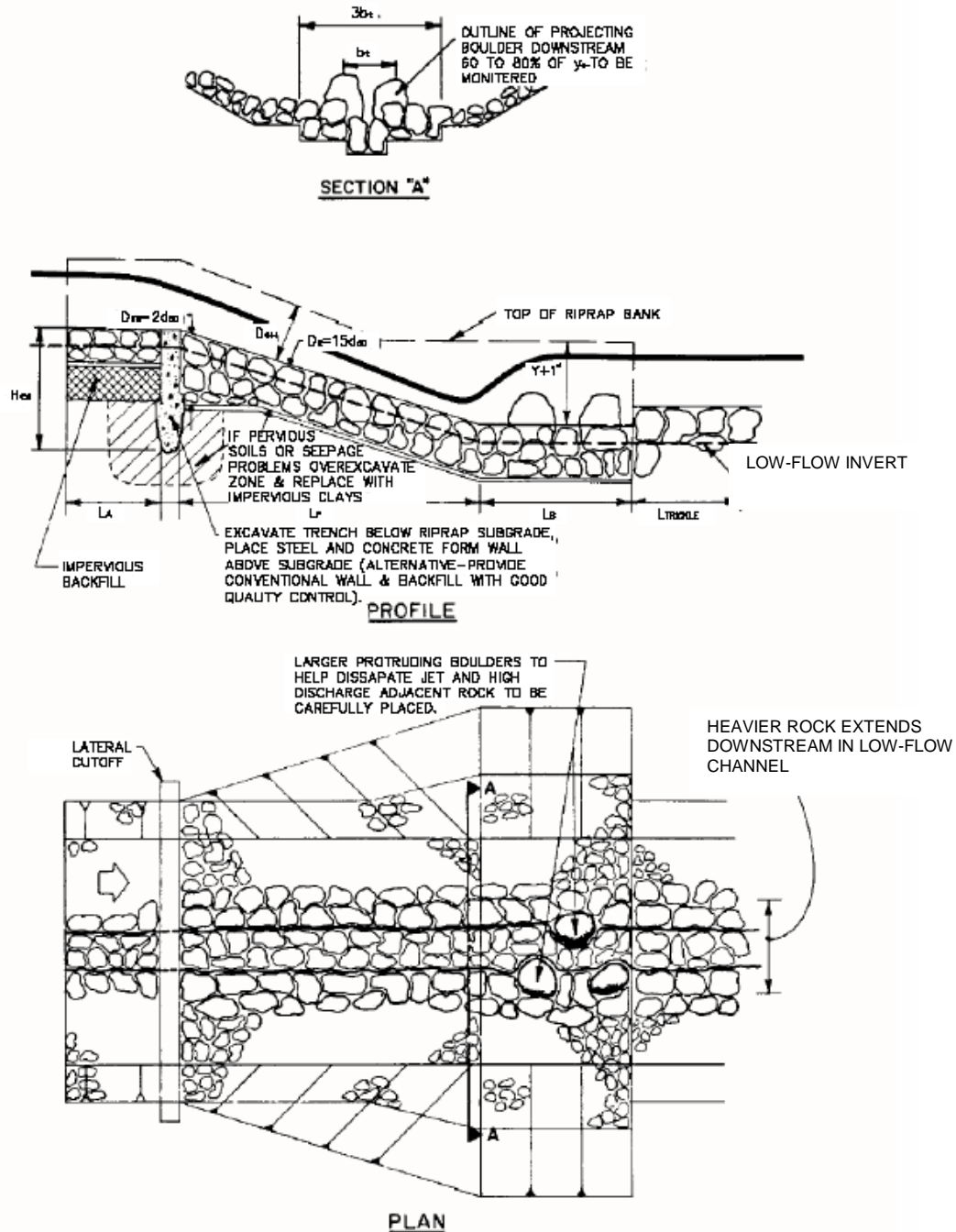

VERSION: April 30, 2009

REFERENCE:

McLaughlin Water Engineers, 1986

FIGURE

835

WTC ENGINEERING, INC

BED STABILIZER DESIGN WITH SHEET PILE CUTOFF

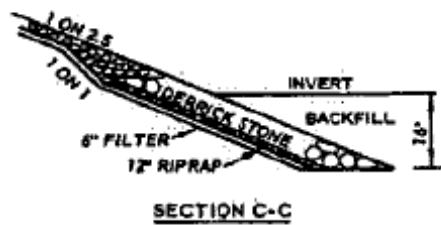
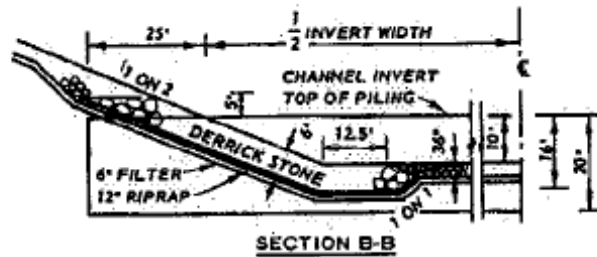
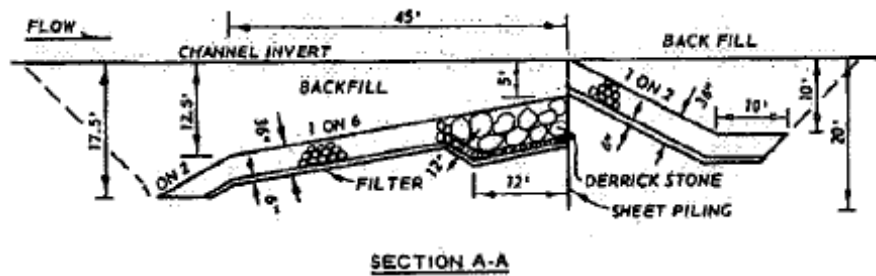
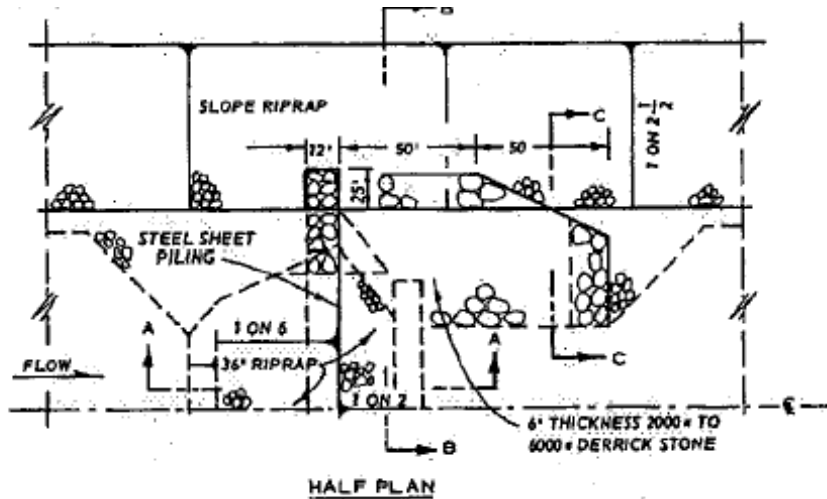

REPRODUCED FROM FIGS. 10 AND 11, REF 60

SHEET PILING STABILIZER

SEE TEXT PAGE 48

VERSION: April 30, 2009

REFERENCE:
U.S. Army Corps of Engineers, 1970

FIGURE
836

WTC ENGINEERING, INC.

ARS-TYPE GRADE CONTROL STRUCTURE WITH PRE-FORMED RIPRAP LINED STILLING BASIN AND BAFFLE PLATE

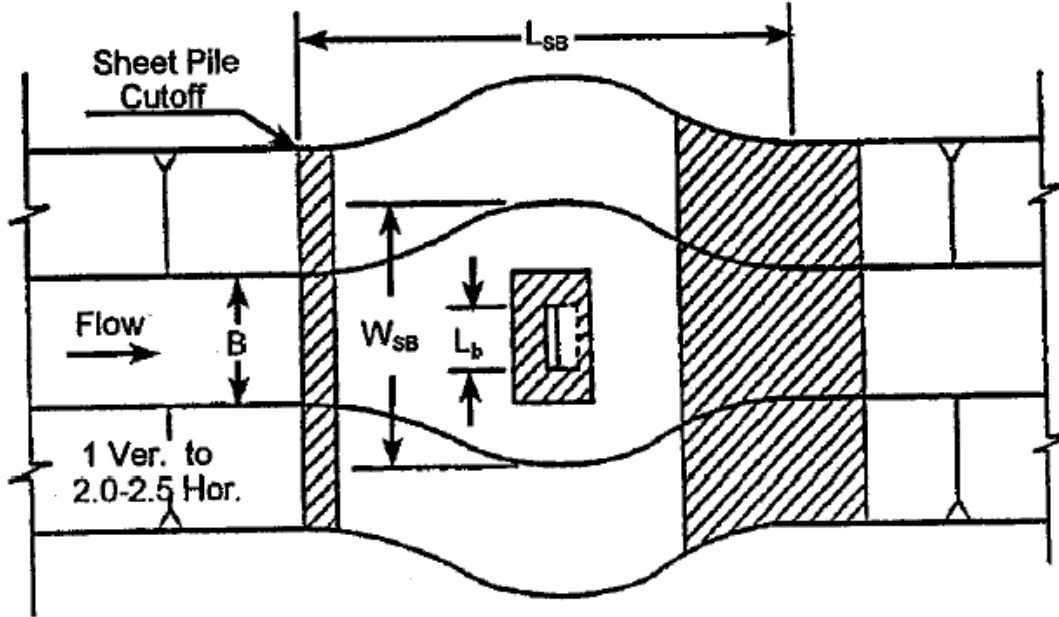

PLAN

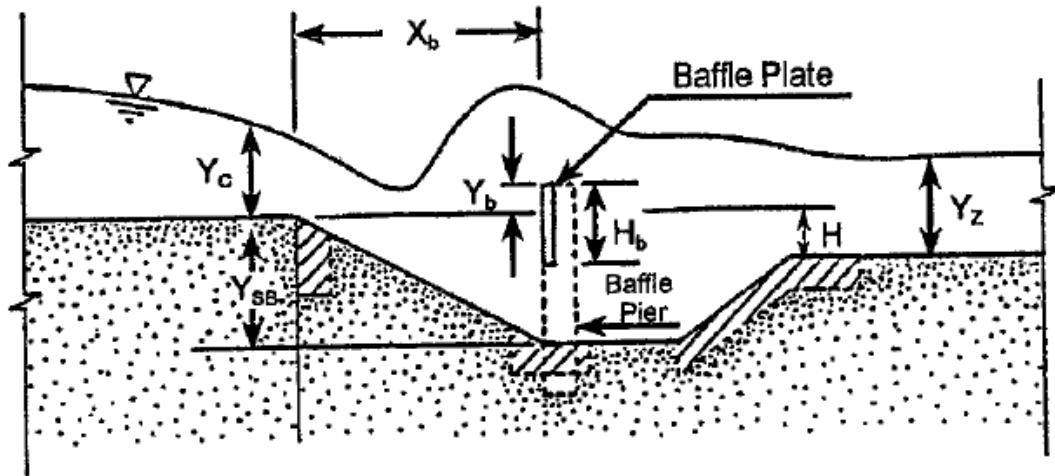

PROFILE

VERSION: April 30, 2009

WTC ENGINEERING, INC.

REFERENCE:

Little and Murphey, 1982

FIGURE

837

SCHEMATIC OF MODIFIED ARS-TYPE GRADE CONTROL STRUCTURE

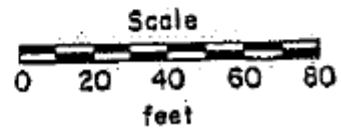
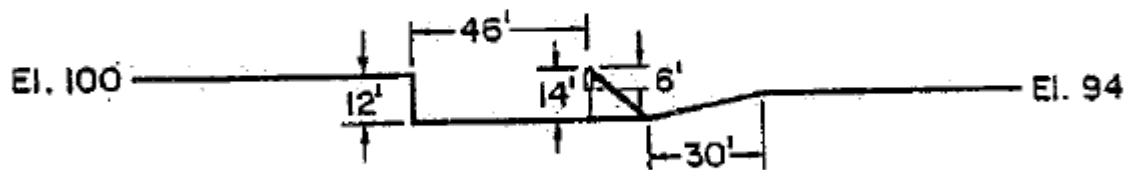
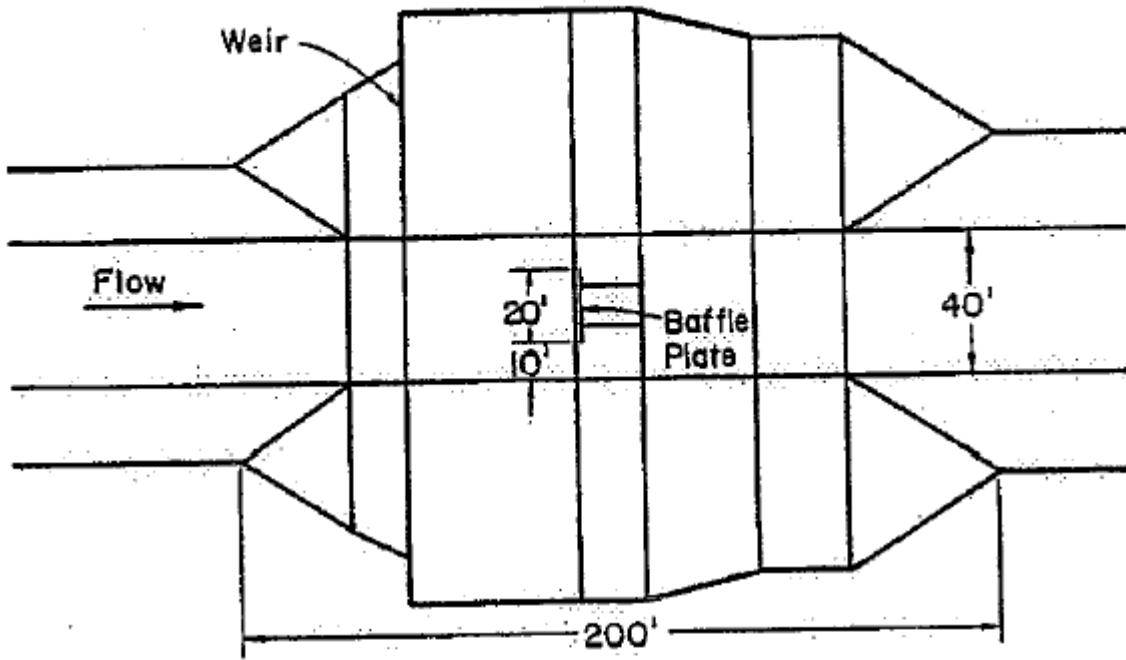

VERSION: April 30, 2009

REFERENCE:

Abt et al., 1994

FIGURE
838

WTC ENGINEERING, INC.

CIT-TYPE DROP STRUCTURE

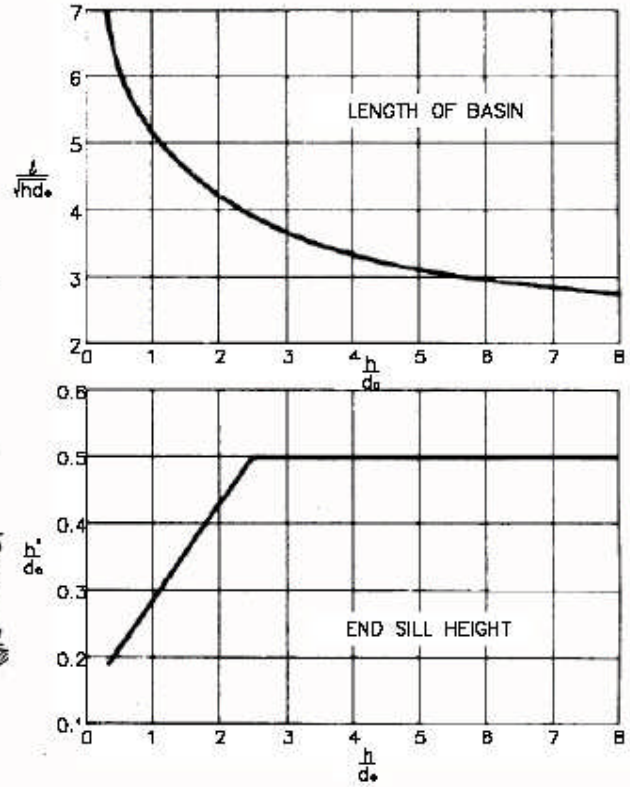
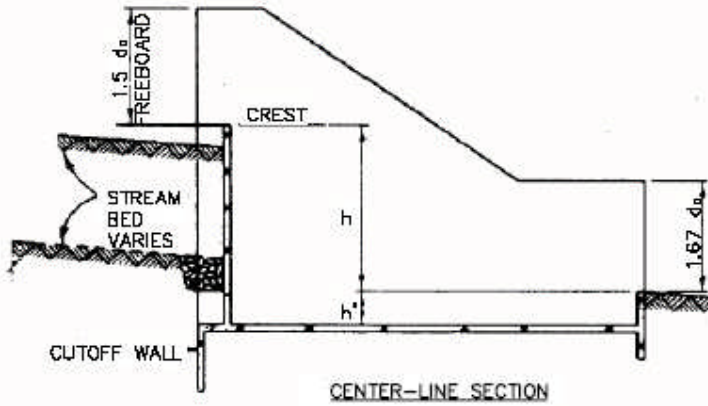
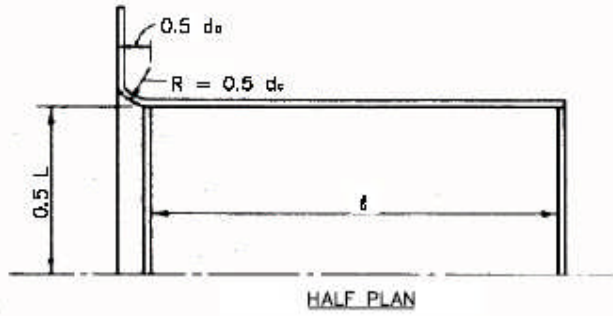

- c = WEIR DISCHARGE = 3.0
- d_c = CRITICAL DEPTH OVER CREST
- h = HEIGHT OF DROP
- h' = HEIGHT OF END SILL
- H = HEAD ON WEIR = $3/2(d_c)$
- l = LENGTH OF BASIN
- L = LENGTH OF WEIR CREST
- Q = DISCHARGE, $CLH^{3/2}$

DETAILS AND DESIGN CHART FOR TYPICAL DROP STRUCTURE

VERSION: April 30, 2009

WJC ENGINEERING, INC.

REFERENCE:

Murphy, 1967

FIGURE 839

ST. ANTHONY FALLS (SAF) TYPE DROP STRUCTURE

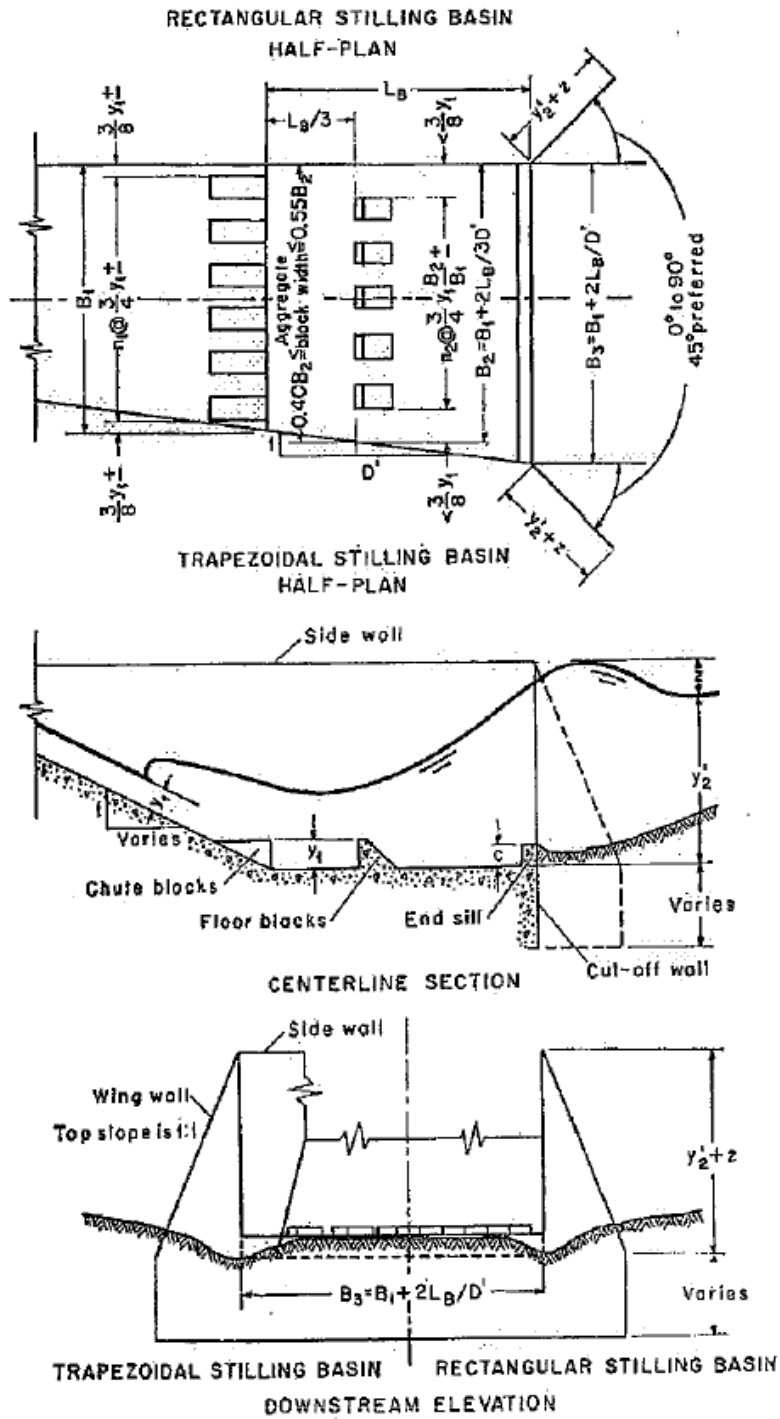

VERSION: April 30, 2009

REFERENCE:

Blaisdell, 1948

FIGURE
840

WTC ENGINEERING, INC.

CONTROL SILL GRADE CONTROL STRUCTURE

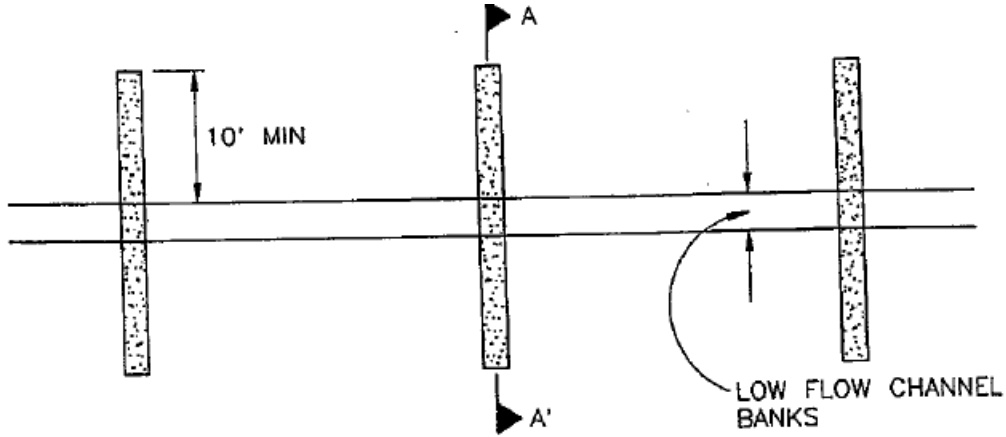

(a) PLAN

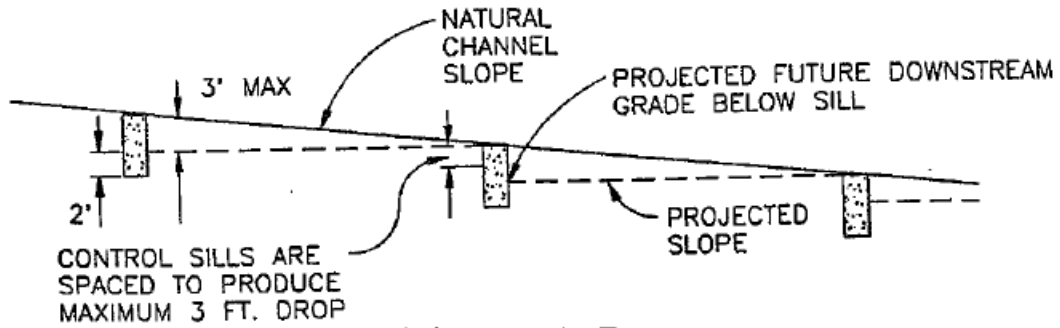

(b) PROFILE

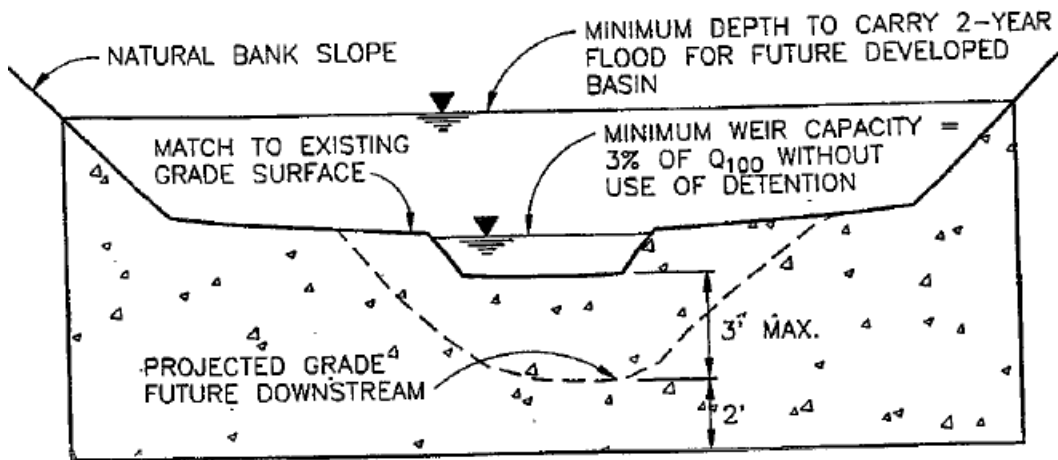

(c) SECTION A-A'

VERSION: April 30, 2009

REFERENCE:

UDFCD, 1990

FIGURE

841

WTC ENGINEERING, INC.

EXAMPLE: CROSS-SECTION OF DOE CREEK

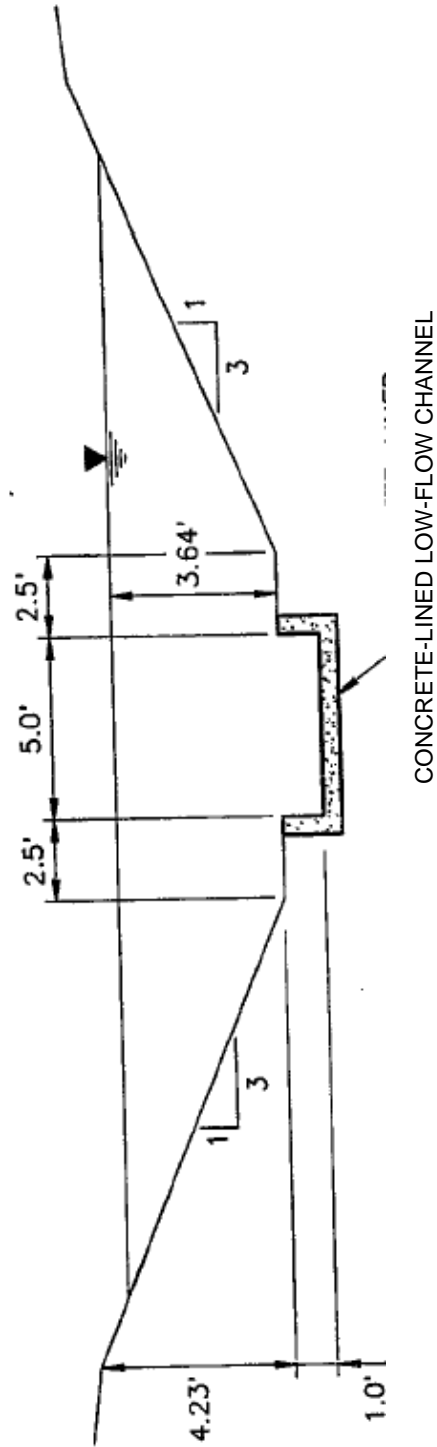

VERSION: April 30, 2009

REFERENCE:

FIGURE
842

WTC ENGINEERING, INC.

DEGRADED CHANNEL PROFILE BY THE THREE-SLOPE METHOD

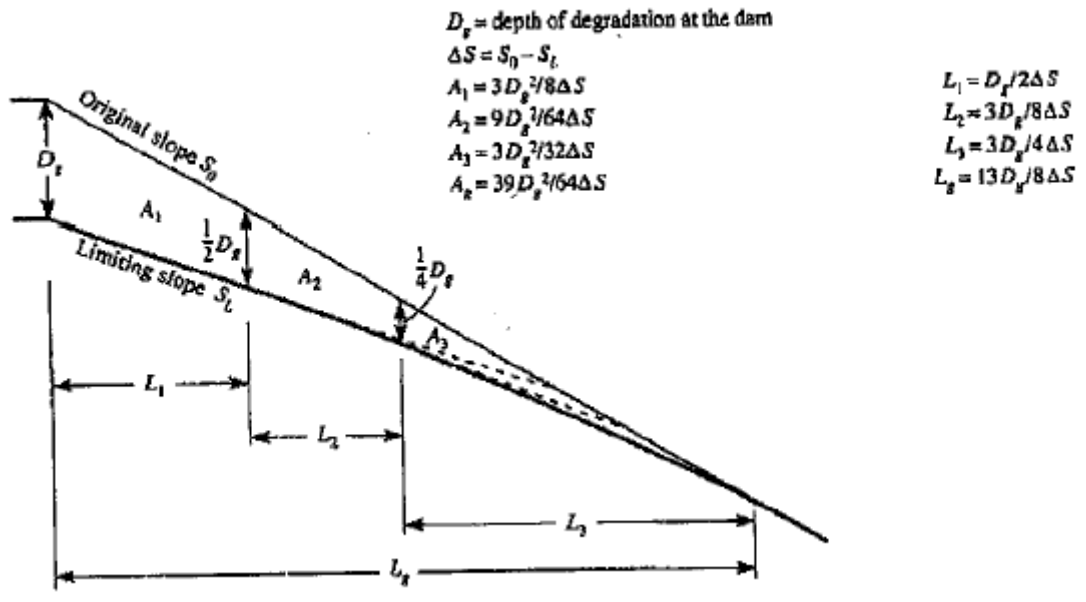

VERSION: April 30, 2009

REFERENCE:
U.S. Bureau of Reclamation, 1987

FIGURE
843

WTC ENGINEERING, INC.

SECTION 900 - STORM SEWER SYSTEM

TABLE OF CONTENTS

	<u>Page</u>
901 INTRODUCTION	902
902 DESIGN PARAMETERS	902
902.1 ALLOWABLE STORM SEWER CAPACITY	902
902.2 ALLOWABLE STORM SEWER VELOCITY	903
902.3 MANNING'S ROUGHNESS COEFFICIENT	903
902.4 STORM SEWER LAYOUT	903
902.5 ALLOWABLE STORM INLET TYPES AND CAPACITY FACTORS	905
902.6 OTHER CLOSED CONDUIT CRITERIA	905
903 CONSTRUCTION STANDARDS	905
903.1 STORM SEWER PIPE	905
903.2 MANHOLES	906
903.3 STORM SEWER INLETS	906
903.4 STORM SEWER OUTLETS	906
904 STORM SEWER HYDRAULICS	906
904.1 HYDRAULIC ANALYSIS	906
904.2 ENERGY LOSS CALCULATIONS	907
905 STORM INLET HYDRAULICS	910
905.1 INLETS ON CONTINUOUS GRADE	911
905.2 INLETS IN A SUMP CONDITION	912
905.3 INLET SPACING	913
905.4 INLET CAPACITY FOR MAJOR STORM ANALYSIS	913
906 STORM SEWER SYSTEM DESIGN	914
906.1 INITIAL STORM SEWER SIZING	914
906.2 FINAL STORM SEWER SIZING	914
907 EXAMPLE APPLICATION	915
907.1 INTRODUCTION	915
907.2 EXAMPLE: STORM SEWER HYDRAULIC ANALYSIS	915

LIST OF TABLES

901	STORM SEWER DESIGN AND ANALYSIS PARAMETERS
902	ALLOWABLE STORM INLET TYPES AND CAPACITY FACTORS
903	STORM SEWER ENERGY LOSS COEFFICIENTS
904	SPLASH VELOCITY CONSTANTS FOR VARIOUS TYPES OF GRATES
905	SAG INLET PARAMETERS AND COEFFICIENTS

LIST OF FIGURES

- 901 HYDRAULIC PROPERTIES OF CIRCULAR PIPE
- 902 HYDRAULIC PROPERTIES OF HORIZONTAL ELLIPTICAL PIPE
- 903 HYDRAULIC PROPERTIES OF ARCH PIPE
- 904 ENERGY LOSS COEFFICIENT IN STRAIGHT THROUGH MANHOLE
- 905 EXAMPLE PROBLEM: SCHEMATIC DRAWING OF STORM SEWER SYSETM
- 906 EXAMPLE PROBLEM: STORM SEWER PROFILE
- 907 EXAMPLE PROBLEM: STORM SEWER HYDRAULIC CALCULATIONS (STANDARD
FORM – 3)

SECTION 900

STORM SEWER SYSTEM

901 INTRODUCTION

A storm sewer system consists of a series of pipes, manholes, and inlets which generally convey storm runoff from streets (gutter flow) to open channels or detention facilities. Storm sewers are generally utilized when the flow carrying capacity of a street (gutter) is exceeded by the calculated storm runoff contributing to the street (gutter). Inlets to the storm sewer are sized to reduce the amount of street (gutter) flow to a level where the downstream street (gutter) flow is not exceeded before the location of the next inlet. Manholes in the sewer system are provided to allow access to the storm sewer for inspection and maintenance of the storm sewer. Streets shall be designed to meet the drainage criteria for both the major and the minor storm events (see section 304.4). Storm sewer systems are required when the allowable street flow capacity for these events is exceeded.

The size of the storm sewer system may be governed by the minor storm flows as a result of the incremental flow capacity between the allowable street flow during major and minor storms being generally greater than the incremental difference in the peak runoff from major and minor storms. Where this is the case, the storm sewer system will naturally carry some runoff in excess of the minor storm capacity during major storms due to natural surcharging of the storm sewer system.

There are special conditions, however, when the storm sewer system design is governed by the major storm flows, with no consideration given to the street flow capacity. These situations are as follows:

1. Locations where street flow is collected in a sump with no allowable overflow capacity.
2. Locations where the desired major storm flow direction is not reflected by the street flow direction during a major storm (i.e., flow splits at intersections).
3. Locations where the subject storm sewer system is accepting flows from an upstream storm sewer system or branch which is designed for major storm capacity.
4. Regional storm sewers.
5. Where required by Jurisdictional Entity.

The storm sewer system designer must be aware that if a storm sewer is to be designed to carry major storm flows, then the inlets to the storm sewer must be designed accordingly.

902 DESIGN PARAMETERS

902.1 ALLOWABLE STORM SEWER CAPACITY

The storm sewer system shall be designed to convey the minor storm flows (design storm) under open channel conditions and the portion of the major storm flows required to be conveyed in the storm sewer under open channel or surcharged (pressure flow) conditions. (See Sections 303 and 304 for major storm flow requirements.) Surcharging the storm sewer system during the minor storm requires the approval of the Jurisdictional Entity. The maximum level of surcharging for the capacity analysis shall be limited to maintaining the HGL to 1 foot below the final grade above the storm sewer at all

locations. Special site conditions that warrant additional surcharging may require properly anchored locking type manhole covers or grated covers and will be reviewed on a case by case basis.

The energy grade line (EGL) and hydraulic grade line (HGL) shall be calculated to include all hydraulic losses including friction, expansion, contraction, bend, and junction losses. The methods for estimating these losses and for calculating the EGL and HGL are presented in the following sections.

902.2 ALLOWABLE STORM SEWER VELOCITY

The maximum allowable storm sewer velocity is dependent on many factors including the type of pipe, the acceptable wear level during the pipe design life, proposed flow conditions (open channel versus pressure flows), and the type and quality of construction of joints, manholes, and junctions. In consideration of the above factors, the maximum velocity in all storm sewers shall be limited to 20 ft/sec.

The need to maintain a self-cleaning storm sewer system is recognized as a goal to minimize the costs for maintenance of storm sewer facilities. Sediment deposits, once established, are generally difficult to remove without pressure cleaning equipment. However, the infrequency of storm runoff also presents a problem in obtaining flows large enough to maintain the self-cleaning quality of the design. Thus, a balance must be drawn between obtaining a self-cleaning system and constructing a reasonably sized and sloped storm sewer.

A generally accepted criteria is to maintain a minimum velocity of 3 feet per second (fps) at half or full conduit flow conditions. At half full, the storm sewer will flow under open channel flow conditions and thus the velocity in a given storm sewer is governed by the pipe slope. However, storm sewers generally cannot be constructed at slopes less than 0.25 percent and maintain a smooth even invert. Therefore, the minimum allowable storm sewer slope shall be 0.25 percent.

902.3 MANNING'S ROUGHNESS COEFFICIENT

All open channel storm sewer system hydraulic calculations shall be performed using Manning's Formula (see Equation 801). Manning's roughness factor or "n" value is determined based on the surface roughness of the storm sewer pipe material. In addition, for a given pipe material, Manning's roughness coefficient theoretically varies based on depth of flow in the pipe. For the purposes of this Manual, Manning's roughness coefficient is assumed to be constant for all depths of pipe flow.

Various pipe manufacturers have determined Manning's roughness coefficients for use with their specific product. However, for storm sewer hydraulic design, Manning's roughness coefficient should also account for additional friction losses from pipe joints, potential debris and sediment in the storm runoff, and the pipe interior surface condition over the entire design life of the pipe. Therefore, presented on Table 901 are the Manning's roughness coefficients to be used for all storm sewer design and analysis prepared in accordance with this Manual.

902.4 STORM SEWER LAYOUT

The layout of a storm sewer system is governed by many factors including existing utility locations, street alignment, inlet placement, outfall location, and surface topography. These factors place constraints around which the storm sewer must be designed and still operate as an effective system. In addition, these constraints have inherent priorities as to which constraint takes precedence over the other constraints (i.e., relocating water lines versus designing around sanitary sewers).

The storm sewer system must also take priority when other constraints would cause undesirable hydraulic conditions to occur in the storm sewer system if the system were to be designed around the

constraint. Therefore, limits are necessary in the storm sewer layout to prevent undesirable hydraulic conditions. The limits on vertical and horizontal alignments are presented in the following sections.

902.4.1 VERTICAL ALIGNMENT

902.4.1.1 Minimum and Maximum Cover

The required cover over a storm sewer pipe is dependent on many factors including the design pipe strength, pipe size, and cover material. For practical purposes, the storm sewer should be protected from potential surface disturbances and displacements. Therefore, the minimum allowable cover over the storm sewer pipe shall be one foot or greater at any point along the pipe. If there is less than 1 ½ foot of cover, the pipe shall be concrete encased. The maximum cover is contingent upon the design pipe strength. Pipe strength calculations shall be submitted when pipe cover is less than:

1.5 feet or greater than 10 feet for RCP

2.5 feet or greater than 10 feet for all other pipe

902.4.1.2 Manhole

To maintain hydraulic efficiency and adequate maintenance access, a manhole shall be located at all changes in pipe size, direction (including bends where allowed), elevation and grade for all pipes with a diameter (or rise dimension) of less than 48 inches. In the Cities of Reno and Sparks, manholes will be required at inlet laterals where the lateral is not easily accessible for cleaning or maintenance and at the end of public lines. In unincorporated Washoe County, manholes will be required at inlet laterals and at the ends of public lines. For pipes with a diameter (or rise dimension) of 48 inches and greater, the designer shall consult with the Jurisdictional Entity for location of manholes based on hydraulic and maintenance considerations. In addition, the maximum spacing between manholes for various pipe sizes shall be in accordance with Table 901.

902.4.2 HORIZONTAL ALIGNMENT

The horizontal alignment of storm sewers shall generally be straight between manholes. However, if a curvilinear alignment is justified, the storm sewer may be constructed with curvilinear alignment by the pulled-joint method, pipe bends, or using radius pipe. The radius of curvature for pulled-joint construction is dependent on the pipe length, diameter and the permitted opening in the joint. The maximum allowable joint pull for pulled-joint construction shall be as presented in Table 901. For radius pipe, the maximum bevel angle shall not exceed 5 degrees. The maximum deflection angle for pipe bends shall not exceed 22.5 degrees per pipe section.

902.4.3 UTILITY CLEARANCES

Storm sewers should be located to minimize potential cross contamination between the potable water supply, sanitary sewers, and reclaimed water lines. This should be accomplished through distancing the storm sewer from potable water, sanitary sewer and reclaimed water lines where at all possible or adding additional leakage protection at joints. Storm sewers should also be located to minimize disturbance of existing and/or future potable water supply, sanitary sewer and reclaimed water lines due to storm sewer construction. For utility crossing and separation requirements, consult with the appropriate utility, jurisdictional entity and the Nevada Administrative Code.

902.5 ALLOWABLE STORM INLET TYPES AND CAPACITY FACTORS

Standard storm inlet types have been adopted as part of the Standard Specifications for Public Works Construction. The allowable use of these storm inlet types is presented on Table 902. Also presented in Table 902 are the allowable inlet capacity factors for each of the standard inlets. These capacity factors are applied to the theoretical capacity of the inlets to account for conditions which decrease the capacity of the standard inlets. These conditions include plugging from debris and sediment, pavement overlaying, variations in design assumptions, and the general deterioration of the inlet conditions over time. Storm inlet hydraulics is discussed in Section 905.

902.6 OTHER CLOSED CONDUIT CRITERIA

902.6.1 ANGLE OF CONFLUENCE

The angle of confluence between storm drain lines shall not exceed 90 degrees. Connections shall not be made that may create conditions of adverse flow or where hydraulic calculations indicate that excessive head losses may occur due to the confluence.

903 CONSTRUCTION STANDARDS

The following sections present the standards for construction of storm sewer systems. Detailed specifications for specific parts of the following standards are presented in the current version of the Standard Specifications for Public Works Construction including all future amendments. Where these detailed Standard Specifications are available, they shall be considered as an addition to the generalized standards presented in the following sections. The designer shall be responsible for referencing the most current version of the Standard Specifications.

903.1 STORM SEWER PIPE

903.1.1 SIZE

The minimum allowable pipe size for storm sewers is dependent upon a practical size and length for maintenance and inspection of the storm sewer. Therefore, the minimum pipe size for storm inlet laterals to the storm sewer mains and for storm sewer mains shall be 12 inches in diameter for round pipe or equivalent for non-round pipe. The City of Reno allows 10-inch laterals for lengths of 80 feet or less.

903.1.2 MATERIAL AND SHAPE

The material and shape of the storm drain shall be in accordance with the current version of the Standard Specifications for Public Works Construction. Public storm sewers shall be reinforced concrete pipe or boxes or other materials as allowed by the Jurisdictional Entity (See Table 301). Other materials or shapes may be used for storm sewer construction upon approval by the appropriate Jurisdictional Entity. Documentation must be submitted for review which shows that the subject material has a design life similar to the above materials and that the interior lining, if any, will maintain the design Manning's roughness coefficient value for the life of the pipe material.

903.1.3 JOINT SEALANTS AND GASKETS

Pipe joints shall be specified on the improvement plans to the satisfaction of the Jurisdictional Entity and may be open or sealed with either joint sealants or gaskets. Pipe joints in the Cities of Reno and Sparks shall be sealed, unless otherwise specified by the Jurisdictional Entity. Joint sealants are generally mastics which consist of bitumen and inert mineral fillers or joint mortar. The mastic is

easily applied in the field but may not always provide a water tight joint. Joint gaskets are generally made of rubber and are either cemented to, recessed in, or rolled on the pipe joint. These gaskets generally provide a water tight seal and can withstand internal pressure. Rubber gasket joints shall be used for all installations where the pressure head exceeds five feet for the design flow. The pressure head is computed as the difference between the hydraulic grade line and the soffit of pipe.

903.2 MANHOLES

Manholes shall be constructed in accordance with the Standard Specifications for Public Works Construction. Pipes may be directly cast into the manhole base. The Jurisdictional Entities may require gasketed joints, locking type manhole covers, and/or grated manhole covers.

903.3 STORM SEWER INLETS

Storm sewer inlets shall be constructed in accordance with the Standard Specifications for Public Works Construction.

903.4 STORM SEWER OUTLETS

Storm sewer outlets shall be constructed with outlet erosion protection for discharges to channels with unlined bottoms in accordance with the following:

Outlet Velocity (ft/sec)	Required Outlet Protection
< 5	Minimum Rip-rap Protection (Section 807.3)
> 5 and < 15	Rip-rap Protection (Section 807.3) or Energy Dissipator(Section 1202.2)
> 15	Energy Dissipator (Section 1202.2)

For channels with lined bottoms, the outlet discharge velocity must not exceed the maximum allowable channel velocity without an energy dissipation structure.

904 STORM SEWER HYDRAULICS

Presented in this section are the general procedures for hydraulic design and evaluation of storm sewers. The user is assumed to possess a basic working knowledge of storm sewer hydraulics and is encouraged to review text books and other technical literature available on the subject.

904.1 HYDRAULIC ANALYSIS

Storm sewers in the Washoe County area will typically be designed for open channel flow conditions for the minor storm; however, portions of the storm sewer may also be under pressure flow conditions (i.e., very flat slopes, major storm flows). Therefore, the storm sewer capacity analysis must account for changes in flow conditions (open channel versus pressure flow) in the HGL and EGL calculations. The HGL for the major and minor storm flows shall be shown graphically on all final storm sewer improvement construction plans as follows:

City of Reno: Show the HGL for all major and minor storm flows.

City of Sparks: Show the HGL for all minor storm flows and show the HGL for major storm flows if it is above the top of the pipe. Where the HGL for the major storm is below the top of

pipe, a note shall be added to the improvement plans stating that the major storm HGL is contained within the pipe.

Unincorporated Washoe County: Show the HGL for the minor and/or major storm flows if it is above the top of the pipe. Where the HGL for the major storm is below the top of pipe, a note shall be added to the improvement plans stating that the major storm HGL is contained within the pipe.

Many computer programs are now available which perform hydraulic computations for storm sewer hydraulics. However, these programs are only allowed to be used for final design if the user can demonstrate that the results of the program are consistent with the results obtained by using the energy loss equations and coefficients presented in this Manual. The Jurisdictional Entities may, at their discretion, maintain a list of computer programs allowed for use in the storm sewer hydraulic computations.

904.1.1 PRESSURE FLOW ANALYSIS

When a storm sewer is flowing under a pressure flow condition, the energy and hydraulic grade lines may be calculated using the pressure-momentum theory. The capacity calculations generally proceed from the storm sewer outlet upstream accounting for all energy losses. These losses are added to the EGL and accumulate to the upstream end of the storm sewer. The HGL is then determined by subtracting the velocity head, H_v , from the EGL at each change in the EGL slope. To assist in accounting for and computing the energy losses and EGL, a pressure storm sewer computation form (Standard Form 3) is provided in this Manual; use of other forms that provide the same information is subject to the approval of the Jurisdictional Entity

904.1.2 PARTIAL FULL FLOW ANALYSIS

When a storm sewer is not flowing full, the sewer acts like an open channel and the hydraulic properties can be calculated using open channel techniques. For convenience, charts for various culvert shapes have been developed by the pipe manufacturers for calculating the hydraulic properties associated with partial full flow (Figures 901, 902, and 903). The data presented assumes that the friction coefficient, Manning's roughness coefficient, does not vary throughout the depth.

For partial full flow analysis, the HGL and EGL are parallel when the flow reaches normal depth. The designer should check the available energy at all junctions and transitions to determine whether or not the flow in the storm sewer will be pressurized due to backwater effects even if the design flow is less than the full flow capacity of the storm sewer. In this case, a hydraulic jump will occur and the pipe should be structurally designed to accommodate the jump.

904.2 ENERGY LOSS CALCULATIONS

Presented in this section are the energy loss equations and coefficients for use in the hydraulic analysis of storm sewer systems. All storm sewer analysis in the Washoe County area shall account for energy losses using the equations and coefficients in this section.

904.2.1 PIPE FRICTION LOSSES

Pipe friction losses shall be calculated using an equation for full flow conditions derived from Manning's equation as follows:

$$S_f = FH_v / R^{1.33} \quad (902)$$

where, S_f = Friction Slope (ft/ft);
 H_v = Velocity Head (ft); and
 R = Hydraulic Radius (ft)

The flow coefficient, F , is related to the Manning's "n" value for the pipe as follows:

$$F = 2gn^2 / 2.21 \quad (903)$$

where, n = Manning's roughness coefficient, and
 g = Gravitational acceleration, 32.2 ft/sec².

The total head loss due to friction in a length of pipe is then equal to the friction slope times the pipe length.

904.2.2 TRANSITION LOSSES

Generally, between the inlet and outlet, storm sewer flow encounters a variety of configurations in the flow passageway such as changes in pipe size, branches, bends, junctions, expansions, and contractions. These shape variations impose losses in addition to those resulting from pipe friction. Transition losses are the result of fully developed turbulence and are expressed as:

$$H_L = K(V^2 / 2g) \quad (904)$$

where, H_L = Head loss (ft);
 K = Loss coefficient;
 V = Average flow velocity (ft/sec)
 g = Gravitational acceleration, 32.2 ft/sec²

The following is a discussion of a few of the common types of transition losses encountered in storm sewer system design. The reader is referred to standard hydraulic references and text books for additional transition loss discussion. In the following equations, subscripts 1 and 2 denote the upstream and downstream sections, respectively.

904.2.2.1 Expansion Losses

Expansion in a storm sewer conduit will result in a shearing action between the incoming high velocity jet and the surrounding sewer boundary. As a result, much of the kinetic energy is dissipated by eddy currents and turbulence. The head loss is expressed as:

$$H_L = H_e (V_2^2 / 2g) [A_2 / A_1 - 1]^2 \quad (905)$$

in which, A is the cross-sectional flow area, V is the average flow velocity, and K_e is the expansion loss coefficient. The value of K_e varies from about 1.0 for a sudden expansion to about 0.2 for a well designed expansion transition. Table 903 (A) presents the expansion loss coefficients for various flow conditions.

904.2.2.2 Contraction Losses

The head loss due to contraction is expressed as:

$$H_L = K_c (V_2^2 / 2g) \quad (906)$$

Where, K_c is the contraction loss coefficient. K_c varies from about 0.4 for large pipe size differences (>10:1) to about 0.1 for minor pipe size differences. Table 903 (B) presents the contraction loss coefficients for various flow conditions.

904.2.2.3 Bend Losses

The head losses for bends, in excess of that caused by an equivalent length of straight pipe, are expressed as:

$$H_L = K_b(V_2^2 / 2g) \tag{907}$$

in which, K_b is the bend loss coefficient. The bend loss coefficient has been found to be a function of: (a) the ratio of the radius of curvature of the bend to the width of the conduit, (b) deflection angle of the conduit, (c) geometry of the cross section of flow, and (d) the Reynolds Number and relative roughness. Tables showing the recommended bend loss coefficients are presented in Table 903 (C).

904.2.2.4 Junction and Manhole Losses

A junction occurs where one or more branch sewers enter a main sewer, usually at manholes. The hydraulic design of a junction is in effect the design of two or more transitions, one for each flow path. Allowances are made for head losses due to the impacts at the junctions. The head loss at a junction is expressed as:

$$H_L = (V_2^2 / 2g) - K_j(V_1^2 / 2g) \tag{908}$$

where V_2 is the outfall flow velocity; V_1 is the inlet velocity; and K_j is the junction coefficient. Because of the difficulty in evaluating hydraulic losses at junctions due to the many complex conditions of pipe size, geometry of the junction and flow combinations, a simplified table of loss coefficients has been prepared. Table 903 (D) presents the recommended energy loss coefficients for typical manhole or junction conditions that will be encountered in the urban storm sewer system. This equation is valid for junctions and manholes where the incoming flow is greater than 10 percent of the main line flow. If the incoming lateral flow is less than 10 percent of the main line flow, this head loss equation is invalid and Equation (909) should be used.

For straight flow through manholes (single pipe with no inlet laterals), the head loss through the manhole is similar to a pipe bend. For this condition, the head loss at the manhole is expressed as:

$$H_L = K_m(V_2^2 / 2g) \tag{909}$$

in which K_m is the manhole loss coefficient. Figure 904 presents value of K_m for various deflection angles.

904.2.2.5 Inlet Losses

When runoff enters a storm sewer system from locations other than street inlets (i.e., open channels), an energy loss occurs at the entrance in the form of a contraction loss. The head loss at storm sewer entrances is expressed as:

$$H_L = K_i (V_2^2 / 2g) \quad (910)$$

in which K_i is the inlet (entrance) loss coefficient. The coefficient K_i is the same as the K_e coefficient used for the entrance loss calculation for culverts. A list of various K_i (K_e) coefficients is presented in Table 1101 in Section 1100.

904.2.2.6 Outlet Losses

When the storm sewer system discharges into open channels, additional losses occur at the outlet in the form of expansion losses.

For most storm sewer outlets, the flow velocity in the storm sewer is greater than the allowable or actual flow velocity in the downstream channel. Therefore, energy dissipating facilities are used to remove excess energy from the storm sewer flow. In addition, the alignment of the storm sewer at the outlet may not be the same as the downstream channel. Therefore, energy is lost in changing the flow direction between the storm sewer to the downstream channel. The head loss at storm sewer outlets is expressed as:

$$H_L = K_o (V_1^2 / 2g) \quad (911)$$

where K_o is the outlet loss coefficient. For all storm sewer outlets, an outlet loss coefficient K_o of 1.0 shall be used.

904.2.2.7 Drop Manholes

Energy losses in drop manholes depend on the amount of drop and the size of pipes entering and leaving the manhole. For purposes of this Manual, energy losses in drop manholes shall be computed as two 90 degree bend losses when the invert of the upstream pipe is higher than the crown of the downstream pipe. When the upstream pipe invert is lower than the downstream pipe crown, the above computed energy loss shall be prorated by the ratio of the difference of invert elevations to the downstream pipe size.

905 STORM INLET HYDRAULICS

Presented in this section is discussion and criteria for sizing and locating storm sewer inlets. The following methodology is based on the procedures described in Hydraulic Engineering Circular (HEC) 22 (USDOT, 2001). In the Washoe County area the allowed standard inlet types are presented in Table 902. For capacity calculations, the inlets are further classified as being on a “continuous grade” or in a “sump”. The term “continuous grade” refers to an inlet so located that the grade of the street has a continuous slope past the inlet and therefore ponding does not occur at the inlet. The sump condition exists whenever water is restricted to the inlet area because the inlet is located at a low point. A sump condition can occur at locations such as a change in grade of the street from negative to positive or at an intersection due to the crown slope of a cross street.

The procedure to define the capacities of standard inlets consists of defining the amount and depth of flow in the gutter and determining the theoretical flow interception by the inlet. To account for effects which decrease the capacity of the various types of inlets, such as debris plugging, pavement overlaying and variations in design assumptions, the capacity for the inlets as calculated using the procedures presented in the following sections should be reduced by the factors presented in Table 902.

The allowable inlet capacity is dependent on the depth of flow as determined from the street capacity calculations (for continuous grade inlets) or on the depth of ponding necessary to accept the desired flow rate (sump conditions). These depths must be kept at or below the allowable flow or ponding depths as indicated in Section 304.4.

Use of computer programs for storm inlet hydraulics calculations is subject to the approval of the Jurisdictional Entity.

905.1 INLETS ON CONTINUOUS GRADE

For the “continuous grade” conditions, the capacity of an inlet is dependent upon many factors including gutter slope, depth of flow in the gutter, height and length of curb opening, street cross slope, and the amount of depression at the inlet. In addition, all of the gutter flow may not be intercepted and some flow may continue past the inlet area (inlet carryover). The amount of carryover must be included in the drainage facility evaluation as well as in the design of the inlet.

a) Grate Inlets on a Continuous Grade

The capture efficiency of a grate inlet depends highly on the width and length of the grate and the velocity of gutter flow. If the gutter velocity is slow and the spread of water does not exceed the grate width, all of the flow will be captured by the grate inlet. This is not normally the case during the minor (design) storm event. The spread of water frequently exceeds the grate width and flow velocity can be rapid. Therefore, some water gets by the inlet. Water going over the grate may be able to “splash over” the grate, and usually little of the water outside of the grate width is captured.

Gutter flow can be divided into two parts, frontal flow and side flow. Frontal flow is that portion of the flow within the width of the grate. The portion of the flow outside the grate width is called side flow. The frontal flow can be evaluated as:

$$Q_w = Q\{1 - [1 - (W / T)]\}^{8/3} \tag{912}$$

where, Q_w = frontal flow within width W in cfs
 Q = total gutter flow in cfs = $(0.56/n) S_x^{5/3} S_L^{1/2} T^{8/3}$;
 S_L = street longitudinal slope in ft/ft;
 S_x = street cross slope in ft/ft;
 W = width of grate in ft;
 T = top width of flow spread in ft.

By definition, the side flow: $Q_s = Q - Q_w$ (912a)

The capture efficiency, E of the grate inlet can be determined by:

$$E = R_f(Q_w / Q) + R_s(Q_s / Q) \tag{913}$$

where, $R_f = Q_{wi}/Q_w = 1.0 - 0.09 (V - V_0)$ for $V \geq V_0$, otherwise $R_f = 1.0$;
 Q_{wi} = frontal flow intercepted by the inlet in cfs;
 V = velocity of flow in the gutter in ft/sec;
 V_0 = splash-over velocity in ft/sec;
 $V_0 = \alpha + \beta L_e - \gamma L_e^2 + \eta L_e^3$ (Guo, 1999);
 L_e = effective unit length of grate inlet in ft;
 $\alpha, \beta, \gamma, \eta$ = constants (see Table 904);
 $R_s = 1/[1+(0.15 V^{1.8})/(S_x L^{2.3})]$;

L = length of grate in ft.

Therefore, the capacity of a grate inlet can be obtained as:

$$Q_i = QE \tag{914}$$

where, Q_i = inlet capacity in cfs.

b) Curb Opening Inlets on a Continuous Grade

The efficiency, E, of a curb opening inlet can be calculated by Equation (915):

$$E = 1 - [1 - (L / L_t)]^{1.8} \text{ for } L < L_t, \text{ otherwise } E = 1.0 \tag{915}$$

where, L = designed/installed curb opening length in ft;

L_t = curb opening length required to capture 100% of gutter flow in ft;

$L_t = 0.6Q^{0.42} S_L^{0.3} (1/(nS_x))^{0.6}$ for undepressed curb opening inlets;

$L_t = 0.6Q^{0.42} S_L^{0.3} (1/(nS_e))^{0.6}$ for depressed curb opening inlets;

$Q = (0.56/n) S_x^{5/3} S_L^{1/2} T^{8/3}$;

T = top width of flow spread in ft

S_L = street longitudinal slope in ft/ft;

n = Manning's roughness coefficient (0.016 for asphalt street with curb and gutter);

S_x = street cross slope in ft/ft;

S_e = equivalent cross slope = $S_x + (a/W)E_0$;

a = gutter depression in ft;

W = depressed gutter section width in ft;

$E_0 = 1 / \{ 1 + (S_w/S_x) / ([1 + (S_w/S_x) / (T/W - 1)]^{8/3} - 1) \}$; and

$S_w = S_x + a/W$ (gutter cross slope)

Therefore, the capacity of curb opening inlet can be determined as:

$$Q_i = QE \tag{916}$$

where, Q_i = inlet capacity in cfs.

905.2 INLETS IN A SUMP CONDITION

The capacity of an inlet in a sump condition is dependent on the depth of ponding above the inlet. Typically, the problem consists of determining the quantity or length of inlets required to reduce the depth of ponding to an acceptable level. The designer should be aware that several inlets or additional inlet length will generally be required when an inlet must be designed to accommodate major storm flow. Also, additional continuous grade inlets may be necessary upstream of the sump location to reduce the depth of ponding at the sump inlets to an acceptable level during major storm events.

A grated inlet in a sump condition operates like a weir when ponding depths are small, but as an orifice under submerged conditions when ponding depths are large. Similarly, curb openings in a sump also operate like a weir under shallow ponding and as an orifice under deep ponding. If the head on the opening is less than the curb height plus the gutter depression, the inlet operates primarily as a weir, otherwise it operates as an orifice.

At all sump locations, the design shall include provisions for emergency overflow if the inlets become completely plugged. The emergency overflow shall be paved or rip-rapped and include an easement for access and maintenance.

The hydraulic capacity of grate, curb-opening, and slotted inlets operating as weirs can be calculated by using equation (917).

$$Q_i = C_w L_w d^{1.5} \quad (917)$$

where, Q_i = inlet capacity in cfs;
 C_w = weir discharge coefficient;
 L_w = weir length in ft; and
 d = flow depth in ft.

This equation applies for uniform cross slope only; see HEC 22 for more equations. The hydraulic capacity of grate, curb-opening, and slotted inlets operating as orifices can be evaluated by using equation (918).

$$Q_i = C_o A_o (2gd)^{0.5} \quad (918)$$

where, Q_i = inlet capacity in cfs;
 C_o = orifice discharge coefficient;
 A_o = orifice area in ft²;
 d = characteristic depth in ft, defined by effective head on the center of the orifice throat (see Table 905); and
 g = 32.2 ft/sec²

This equation applies for horizontal throat only; see HEC 22 for other configurations. Parameters for Equations (917) and (918) are presented in Table 905 for different types of inlets. For depths of water between h and $1.4h$, the designer estimates the depth of water by linear interpolation.

905.3 INLET SPACING

The optimum spacing of storm inlets is dependent upon several factors, including traffic requirements, contributing land use, street slope, and distance to the nearest outfall system. The suggested sizing and spacing of the inlets is based upon an interception rate of 70 to 80 percent. This spacing has been found to be more efficient than spacing using 100 percent interception rate. Using the suggested spacing, only the most downstream inlet in a development would be designed to intercept 100 percent of the flow. Also, considerable improvement in overall inlet system efficiency can be achieved if the inlets are located in the sumps created by street intersections if possible, without overloading of the sump inlets.

Inlets shall be installed at low points of vertical curves, at street intersection sumps, and at sufficient intervals to intake the design peak flow so that said flows will not interfere with traffic or flood adjoining properties.

905.4 INLET CAPACITY FOR MAJOR STORM ANALYSIS

Inlet capacities may be calculated directly from equation (917) or (918) for sump conditions for major storm events. However, for the continuous grade condition, the use of equation (914) or (916) may result in an actual flow depth of less than that otherwise calculated due to the assumption that flow is restricted to the right of way limits. Therefore, for the major storm inlet capacity analysis, the continuous grade inlet capacities shall be reduced by an additional fifteen percent.

906 STORM SEWER SYSTEM DESIGN

Presented in this section are the design procedures for a storm sewer system from preliminary design consideration to final design. A typical drainage system within a development consists of flow in the storm sewer and allowable flow in the gutter, which combined would carry both the minor and major storm flows. The design flow for the storm sewer is generally governed by the amount of runoff in excess of the minor storm street capacity. In some cases, however, the amount of runoff from the major storm in excess of the major storm street capacity may be larger than the excess from the minor storm. In this case, the storm sewer and inlets would need to be designed to accommodate the excess major storm flow. To assist in this analysis, the allowable minor and major storm street capacity should be determined prior to sizing of the storm sewer system (see Section 1000 - Streets).

906.1 INITIAL STORM SEWER SIZING

Preliminary street grades and cross sections must be available to the storm sewer designer so he can calculate the allowable carrying capacity for these streets. Beginning at the upper end of the basin in question, the designer should calculate the quantity of flow in the street until the point is reached at which the allowable carrying capacity of the street matches the design runoff. Initiation of the storm sewer system would start at this point if there is no alternate method of removing runoff from the street surface. Removal of all the street flow by the storm sewer system is not required except at sump areas. However, the sum of the flow in the sewer plus the flow in the street must be less than or equal to the allowable capacity of the street and storm sewer.

For preliminary sizing purposes, the diameter, type of pipe and pipe slope may be determined assuming a full flow pipe capacity based on slope-area calculations. If large energy losses are anticipated (i.e., large junctions, bends), the preliminary pipe size may need to be upsized to assure that the final pressure calculations result in an acceptable HGL and EGL. In some instances, a profile may be required to check utility conflicts or to assure compatibility with the downstream drainage system.

At this point, the preliminary system should be reviewed to check that the system is hydraulically efficient as well as to locate segments which have potentially large energy losses. These segments should be examined carefully and options explored to minimize the energy loss. The designer should also check potential inlet locations to assure that the required inlet capacity is not larger than the allowable inlet capacities.

906.2 FINAL STORM SEWER SIZING

Final design consists of the preparation of plan, profiles and specifications for the storm sewer system in sufficient detail for construction. The first step consists of the review and verification of the basic data, hydrologic analysis, and storm sewer inlet sizing performed for the preliminary design. Plan and profile drawings are prepared containing the basic data. Drainage sub-basins are revised as necessary, and the design flood peaks recalculated. The storm sewer and inlets are then sized taking into account actual street and storm sewer grades, locations of existing and proposed utilities, and the design of the downstream drainage system.

The calculations also include the determination of the hydraulic and energy grade lines. The manholes, junction structures, or other appurtenant structures must be evaluated for energy losses. If special transitions are required to reduce losses, the structural design of the facilities must include these requirements when detailing the structures.

907 EXAMPLE APPLICATION

907.1 INTRODUCTION

The following example presents the hydraulic analysis of a storm sewer system and demonstrates the use of the energy loss coefficients and the Hydraulic Calculations Standard Form 3.

The following procedure is based on full-flow pipe conditions. If the pipe is flowing substantially full (i.e., greater than 80 percent), the following procedures can be used with minimal loss of accuracy. The designer is responsible for checking the assumptions (i.e., check for full flow) to assure that the calculations are correct.

907.2 EXAMPLE: STORM SEWER HYDRAULIC ANALYSIS

Problem: Compute the EGL and HGL for the storm sewer system presented in plan on Figure 905 and profile on Figure 906. This example problem utilizes allowable street flow calculations performed in Section 1007.1 and runoff calculations performed in Section 711.1. Assume the water surface elevation at the outlet in the detention basin (DP7) is 4922.0 ft.

Solution:

Step1: Based on the allowable street flow calculations performed in the example problem in Section 1007.1, draw a plan view of the necessary storm sewer system (see Figure 905).

Step 2: Determine the location that the calculations will begin and the direction in which they will proceed. In this example, assume the normal depth at the storm sewer outlet is greater than the critical depth ($d_n > d_c$), so the calculations will begin at Point 7 and proceed upstream.

Step 3: Enter the known data into Standard Form 3 (See Figure 907). In this example, the assumed known data is input in columns 1, 2, 6, 10, and 27 and the first row of column 4.

Step 4: Assume a storm sewer type and diameter for the first reach of the storm sewer system and fill in the first row of columns 3, 8, 11 and 12.

Assume $D_{7-4} = 1.5$ ft

The storm sewer velocity is:

$$V_{7-4} = Q/A = 11.2/[3.14(0.75)^2] = 6.3\text{ft/sec}$$

and the velocity head is:

$$H_{v(7-4)} = V^2/(2g) = 6.3^2/(2 \times 32.2) = 0.6\text{ft}$$

Step 5: Determine the starting HGL and EGL elevations.

As previously mentioned, the starting HGL is:

$$\text{HGL}_7 = 4922.0$$

The energy, or head loss at the storm sewer is:

$$H_{LO} = K_o \times H_{v(7-4)} = 1 \times 0.6 = 0.6\text{ft}$$

The initial EGL will be:

$$EGL_7 = HGL_7 + H_{LO} = 1922.0 + 0.6 = 4922.6\text{ft}$$

Input the starting HGL (HGL_7) and EGL (EGL_7) above the first row of columns 24 and 25.

Step 6: Assume a value for the upstream invert elevation of the first storm sewer reach, and fill the first row of columns 5 and 7.

Assume the storm sewer invert elevation as Design Point 4 is 4919.0 ft. The slope in the first reach will be:

$$S_{7-4} = (4919 - 4918)/100 = 0.01\text{ft/ft}$$

Step 7: Calculate the friction slope for this reach.

The flow coefficient is:

$$F = 2gn^2 / 2.21 = 2 \times 32.2 \times 0.013^2 / 2.21 = 0.0049$$

and the hydraulic radius is:

$$R_{7,4} = D_{7-4} / 4 = 1.5 / 4 = 0.375\text{ft}$$

The friction slope is:

$$S_{f(7-4)} = (FH_v) / R^{1.33} = (0.0049 \times 0.6) / (0.375)^{1.33} = 0.011\text{ft/ft}$$

Enter the flow coefficient and the friction slope into the first row of columns 9 and 13, respectively.

Step 8: Compute the average friction slope and input this value into column 14 of the first row.

The average friction slope is the average value of S_f for the current reach and the preceding reach. For the first reach, the average friction slope is equal to the friction slope in the first reach.

$$AveS_f = S_{f7-4} = 0.011\text{ft/ft}$$

Step 9: Calculate the energy loss due to pipe friction in the first reach.

$$H_{f(7-4)} = (Ave.S_{f7-4})(L) = 0.011 \times 100 = 1.1\text{ft}$$

Enter H_{f7-4} in the first row of column 15.

Step 10: Determine the EGL and HGL at the upstream station.

$$EGL_4 = EGL_7 + H_{f(7-4)} = 4922.6 + 1.1 = 4923.7\text{ft}$$

$$HGL_4 = EGL_4 - H_v = 4923.7 - 0.6 = 4923.1\text{ft}$$

Enter EGL_4 in the first row of column 22 and HGL_4 in the first row of column 23.

Step 11: Check that full flow still exists (i.e. $WSEL. > 0.8D$).

$$\text{Flow Depth} = HGL_4 - \text{Invert Elevation at Design Point 4}$$

$$\text{Flow Depth} = 4923.7 - 4919.0 = 4.7 \text{ ft}$$

$$0.8 D = 0.8 \times 1.5 = 1.2 \text{ ft}$$

Since $4.7 > 1.2$, pressure flow exists. Enter "yes" in the first row of column 26.

Step 12: Assume a storm sewer type and diameter from Design Point 4 to Design Point 6 (Reach 2) and a storm sewer invert elevation at Design Point 6, and fill in the second row of columns 3, 4, 5, 7, 8, 9, 11, and 12.

$$\text{Assume } D_{4-6} = 1.5 \text{ ft}$$

$$\text{Upstream invert elevation} = 4919.4$$

$$A_{4-6} = \rho r^2 = \rho(0.75)^2 = 1.77 \text{ ft}^2$$

$$F = 2gn^2 / 2.21 = 2 \times 32.2 \times 0.013^2 / 2.21 = 0.0049$$

$$V_{4-6} = Q / A = 3.6 / 1.77 = 2.0 \text{ ft/sec}$$

$$H_{v(4-6)} = V^2 / (2g) = 2.0^2 / (2 \times 32.2) = 0.1 \text{ ft}$$

Step 13: Check the controlling downstream flow condition for Reach 2. Compare the downstream flow condition for Reach 2 to the upstream flow condition for Reach 1. The highest value controls.

$$EGL_4 \text{ (Downstream of Reach 2)} = (D/S \text{ Invert Elev}_4) + D + H_v$$

$$EGL_4 \text{ (Downstream of Reach 2)} = 4919 + 1.5 + 0.1 = 4920.6 \text{ ft}$$

$$EGL_4 \text{ (upstream of Reach 1)} = 4923.7 \text{ ft}$$

Since EGL_4 (U/S of Reach 1) is greater than EGL_4 (D/S of Reach 2), the controlling downstream energy gradeline elevation is 4923.7 ft. If the downstream EGL of Reach 2 had been greater, this value would be the controlling EGL (and HGL) and entered in columns 24 and 25, respectively. Step 11 would be repeated in the next row down and the calculations would continue in this row with Step 13.

Step 14: Calculate the friction slope for this reach. The flow coefficient does not change.

The hydraulic radius is:

$$R_{4-6} = D_{4-6} / 4 = 1.5 / 4 = 0.375 \text{ ft}$$

The friction slope is:

$$S_{f(4-6)} = (\Phi H_v) / R^{1.33} = (0.0049 \times 0.1) / (0.375)^{1.33} = 0.002 \text{ ft / ft}$$

Enter this value into the second row of column 13.

Step 15: Compute the average friction slope and input this value into the second row of column 14.

$$\text{Ave}S_f = (0.002 + 0.011) / 2 = 0.007 \text{ ft / ft}$$

Step 16: Determine the head loss due to friction in the storm sewer in Reach 2.

$$H_{f(4-6)} = (\text{Ave}S_{f7-4})(L) = 0.007 \times 40 = 0.3 \text{ ft}$$

Enter this value in the second row of column 15.

Step 17: Calculate transition energy losses. In this case, there is a transition loss due to the junction.

Assume Reach 2 enters the junction at Design Point 4 at a 45° skew to the main storm sewer alignment. From Table 903 (D), the loss coefficient will be:

$$K_j = 0.5$$

and the transition loss at the junction will be:

$$H_j = [V_2^2 / (2g)] - K_j [V_1^2 / (2g)] = 0.6 - 0.5 \times 0.1 = 0.6 \text{ ft}$$

Enter this value in the second row of column 17.

For columns 17 through 20, enter the K values acquired from the appropriate tables and figures and the head values calculated from Equations 904 through 911. Separate the loss coefficient, K, and the head value, H, by a slash (/).

Step 18: Calculate the total energy loss and input this value into the second row of column 21.

$$H_{\text{total}} = H_{f(4-6)} + H_j = 0.3 + 0.6 = 0.9 \text{ ft}$$

Step 19: Compute the EGL and the HGL at the upstream station (Design Point 6).

$$\text{EGL}_6 = \text{EGL}_4 + H_{\text{total}} = 4923.7 + 0.9 = 4924.6 \text{ ft}$$

$$\text{HGL}_6 = \text{EGL}_6 - H_v = 4924.6 - 0.1 = 4924.5 \text{ ft}$$

Step 20: Check the full flow still exists.

$$\text{Flow depth} = \text{HGL}_6 - \text{Invert Elevation at DP6}$$

$$\text{Flow depth} = 4924.5 - 4919.4 = 5.1 \text{ ft}$$

Since the flow depth is greater than 0.8 D (5.1 > 1.2), pressure flow exists, and “yes” should be entered in the second row of column 27.

Step 21: Repeat Steps 11 through 19, as needed, to obtain the EGL and HGL for the entire storm sewer system. The results of this analysis are supplied by Figure 907, and the final EGL and HGL are plotted on Figure 906.

Note: The flow velocity in Reaches 2, 3, and 4 under full flow conditions is less than 3 ft/sec. Due to the small amount of flow needed to be carried in these reaches of storm sewer, a low velocity is unavoidable. If the storm sewer flow was not being controlled by the backwater conditions created by the detention basin, the flow velocities in Reach 2, 3, and 4 would be 5.4 ft/sec, 4.9 ft/sec, and 3.6 ft/sec, respectively. These velocities should be sufficient to clean the storm sewer of sediment and debris.

References

Akan, A.O. and R.J. Houghtalen, 2003, *Urban Hydrology, Hydraulics, and Stormwater Quality: Engineering Applications and Computer Modeling*, New York, N.Y.: John Wiley & Sons.

Denver Urban Drainage and Flood Control District, 2001, *Drainage Criteria Manual*.

Guo, J.C.Y., 1999, *Storm Water System Design*, CE5803, University of Colorado at Denver.

USDOT, 2001, *Urban Drainage Design Manual*, Hydraulic Engineering Circular No. 22, U.S. Department of Transportation, Federal Highway Administration, August 2001.

STORM SEWER DESIGN AND ANALYSIS PARAMETERS

A. MANNING'S ROUGHNESS COEFFICIENT (n):

<u>STORM SEWER TYPE</u>	<u>n</u>
CONCRETE	0.013
CORRUGATED METAL (CORRUGATED INTERIOR)	0.024
CORRUGATED METAL (SMOOTH LINED INTERIOR)	0.013
PVC, HDPE (SMOOTH LINED INTERIOR), FIBERGLASS, RESIN	0.010
CEMENT CONCRETE	

B. MANHOLE SPACING

	<u>EQUIVALENT PIPE SIZE (INCHES)</u>	<u>MAXIMUM ALLOWABLE DISTANCE BETWEEN MANHOLES (FEET)</u>
<u>Reno and Sparks</u>	less than 24	350
	24 and larger	600
Unincorporated Washoe County	All diameters	300*
* Exceptions by approval of the Washoe County Engineer		

C. MAXIMUM ALLOWED DEFLECTION FOR PULLED JOINT CONSTRUCTION SHALL BE AS PER MANUFACTURER'S SPECIFICATIONS

VERSION: April 30, 2009	REFERENCE:	TABLE 901
WTC ENGINEERING, INC.		

ALLOWABLE STORM INLET TYPES AND CAPACITY FACTORS

INLET TYPE	STANDARD DRAWING NUMBERS	PERMITTED USE	PERMITTED LOCATION CONDITION	CAPACITY REDUCTION FACTOR
CATCH BASIN TYPE 1 (CURB OPENING)	2-8/W10.1	ALL STREETS* WITH CURB AND GUTTER	SUMP	0.7
CATCH BASIN TYPE 2 (CURB OPENING)	2-9	ALL STREETS* WITH CURB AND GUTTER	C.G. SUMP	0.8 0.7
CATCH BASIN 3-R (GRATE) OR DROP INLET TYPE 1A (COMBINATION)	R-205 W10.2	LOT DRAINAGE SWALE	SUMP	0.5
CATCH BASIN 4-R (COMBINATION)	R-206A W-12	ALL STREETS WITH CURB AND GUTTER	C.G. SUMP	0.7 FOR GRATE/0.8 FOR CURB OPENING 0.5 FOR GRATE/0.7 FOR CURB OPENING
SLOTTED DRAIN	2-22	ALL STREETS WITH CURB AND GUTTER	C.G. SUMP	0.7 0.5

NOTES:

1. C.G. = CONTINUOUS GRADE
2. STANDARD DRAWING NUMBER REFERS TO THE "STANDARD DETAILS FOR PUBLIC WORKS CONSTRUCTION" AS ADOPTED BY THE JURISDICTIONAL ENTITIES, INCLUDING FUTURE AMENDMENTS.
3. CAPACITY FACTOR IS APPLIED TO THE THEORETICAL INLET CAPACITY TO OBTAIN THE ALLOWABLE INLET CAPACITY TO ACCOUNT FOR FACTORS WHICH REDUCE ACTUAL INLET CAPACITY.

* NOT PERMITTED IN ROADWAY SECTION IN UNINCORPORATED WASHOE COUNTY

VERSION: April 30, 2009	REFERENCE:	TABLE 902
WTC ENGINEERING, INC.		

STORM SEWER ENERGY LOSS COEFFICIENTS

(A) EXPANSIONS

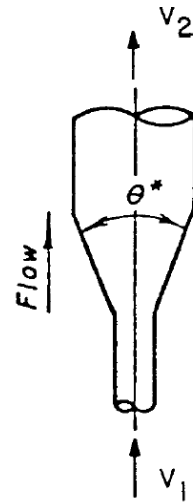
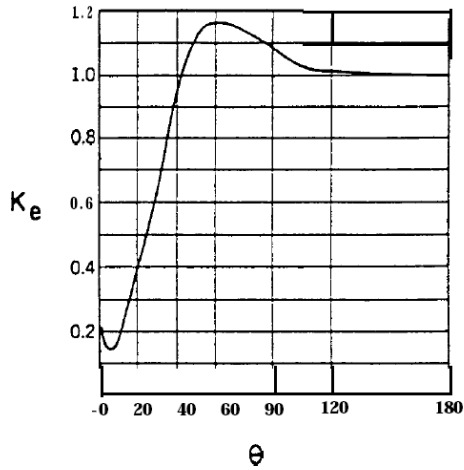

*The angle θ is the angle in degrees between the sides of the tapering section.

(B) CONTRACTIONS

A_2/A_1	K_C
0.1	0.36
0.2	0.34
0.3	0.31
0.4	0.27
0.5	0.22
0.6	0.16
0.7	0.11
0.8	0.05
0.9	0.01
1.0	0.00

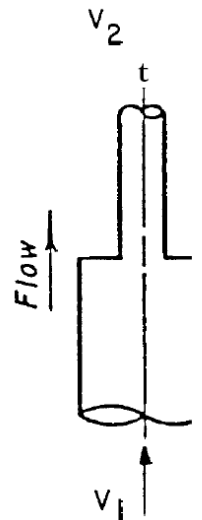

VERSION: April 30, 2009

WTC ENGINEERING, INC.

REFERENCE:

A: Daugherty and Franzini, 1977, *Fluid Mechanics*
 B: Streeter and Wylie, 1979, *Fluid Mechanics*

TABLE

903
 1 of 3

STORM SEWER ENERGY LOSS COEFFICIENTS

(C) BENDS

- I. LARGE RADIUS BENDS
(PIPE DIAMETER > BEND RADIUS)

$$K_b = 0.25(\theta/90)^{0.5}$$

θ	K_b
90"	0.25
60"	0.20
45"	0.18
30"	0.14

NOTE: HEAD LOSS APPLIED AT P.C.

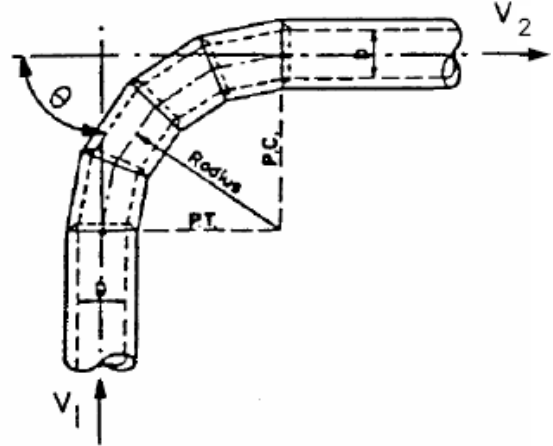

- II. SHARP RADIUS BENDS
(PIPE DIAMETER = BEND RADIUS)

θ	K_b
90"	0.50
60"	0.43
45"	0.35
30"	0.25

NOTE: HEAD LOSS APPLIED AT ENTRANCE TO BEND.

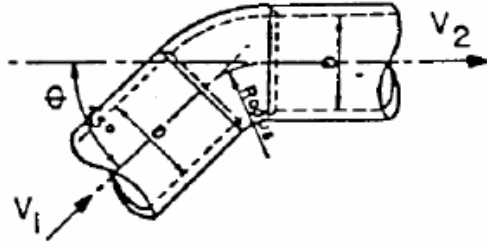

VERSION: April 30, 2009

WTC ENGINEERING, INC.

REFERENCE:

TABLE
903
2 of 3

STORM SEWER ENERGY LOSS COEFFICIENTS

(D) JUNCTIONS

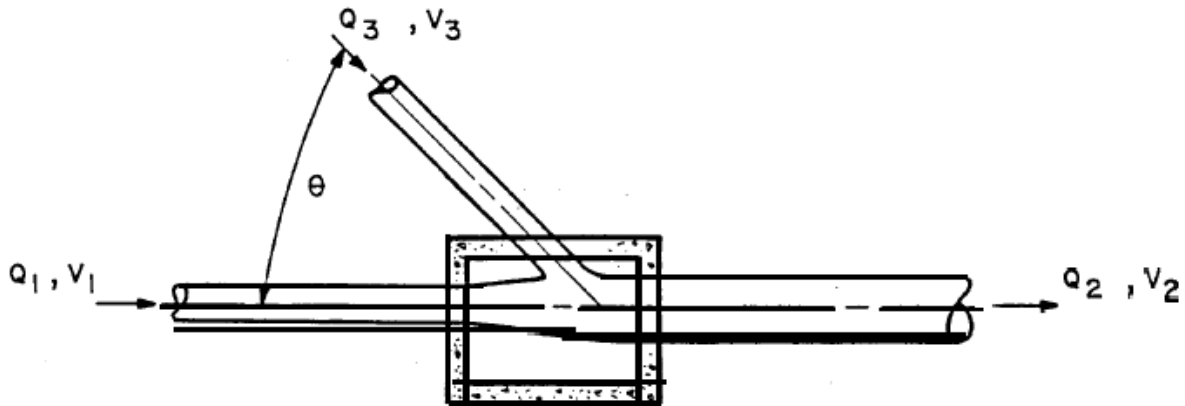

θ	K_j
90"	0.25
60"	0.35
45"	0.50
30"	0.65
15"	0.85

NOTE: Head loss applied at exit of junction

$$H_L = (V_2^2 / 2g) - K_j (V_1^2 / 2g)$$

VERSION: April 30, 2009

WTC ENGINEERING, INC.

REFERENCE:

APWA Special Report No. 49, 1981, "Urban Storm Water Management"

TABLE

903

3 of 3

SPLASH VELOCITY CONSTANTS FOR VARIOUS TYPES OF GRATES

Grate Type	α	β	γ	η
Bar P-1-7/8	2.22	1.03	0.65	0.06
Bar P-1-1/8	1.76	3.12	0.45	0.03
Vane Grate	0.30	4.85	1.31	0.15
45-degree Bar	0.99	2.64	0.36	0.03
Bar P-1-7/8-4	0.74	2.44	0.27	0.02
30-degree bar	0.51	2.34	0.20	0.01
Reticuline	0.28	2.28	0.18	0.01

VERSION: April 30, 2009

REFERENCE:
Guo, 1999

TABLE
904

WTC ENGINEERING, INC

SAG INLET PARAMETERS AND COEFFICIENTS

Inlet Type	C_w	L_w^1	Weir Equation Valid for	Term Definition
Grate	3.00	$L+2W$	$d < 1.79 (A_0/L_w)$	L = length of grate W = width of grate d = depth of water over grate A_0 = clear opening area ²
Curb Opening	3.00	L	$d < h$	L = length of curb opening h = height of curb opening $d = d_i - (h/2)$ d_i = depth of water at curb opening
Depressed Curb Opening ³	2.30	$L+1.8W$	$d < (h+a)$	W = lateral width of depression h = height of curb opening a = depth of curb depression
Slotted Inlet	2.48	L	$d < 0.2$ ft	L = length of slot d = depth at curb

- 1 The weir length should be reduced where clogging is expected.
- 2 The ratio of clear opening area to total area is 0.8 for P-1-7/8-4 and reticuline grates, 0.9 for P-1-7/8 and 0.6 for P-1-1/8 grates. Curved vane and tilt bar grates are not recommended at sag locations.
- 3 If $L > 12$ ft, use the expressions for curb opening inlets without depression.

Inlet Type	C_o	A_o^4	Orifice Equation Valid for	Term Definition
Grate	0.67	Clear opening area ⁵	$d > 1.79 (A_0/L_w)$	d = depth of water over grate
Curb Opening (depressed or undepressed horizontal orifice throat)	0.67	(h) (L)	$d_i > 1.4 h$	h = height of curb opening $d = d_i - (h/2)$ characteristic depth d_i = depth of water at curb opening
Slotted Inlet	0.80	(L)(W)	$d > 0.40$ ft	L = length of slot W = width of slot d = depth at curb

- 4 The orifice area should be reduced where clogging is expected.
- 5 Ratio of clear opening area to total area is 0.8 for P-1-7/8-4 and reticuline grates, 0.9 for P-1-7/8 and 0.6 for P-1-1/8 grates. Curved vane and tilt bar grates are not recommended at sag locations.

VERSION: April 30, 2009

REFERENCE:

Adapted from Akan and Houghtalen, 2003

TABLE
905

WTC ENGINEERING, INC.

HYDRAULIC PROPERTIES OF CIRCULAR PIPE

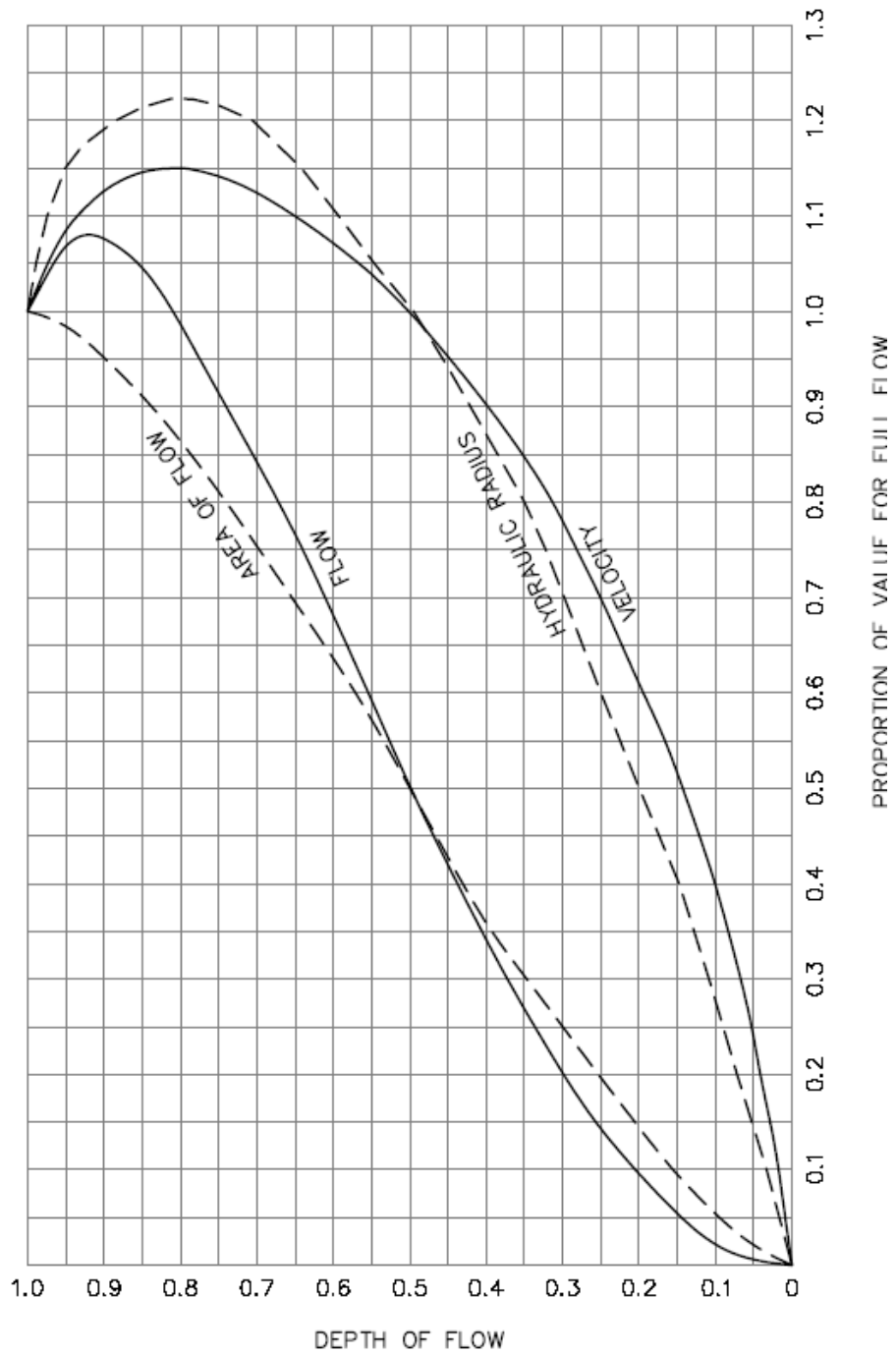

VERSION: April 30, 2009

WTC ENGINEERING, INC.

REFERENCE:
ACPA, *Concrete Pipe Design Manual*, 2007

FIGURE
901

HYDRAULIC PROPERTIES OF HORIZONTAL ELLIPTICAL PIPE

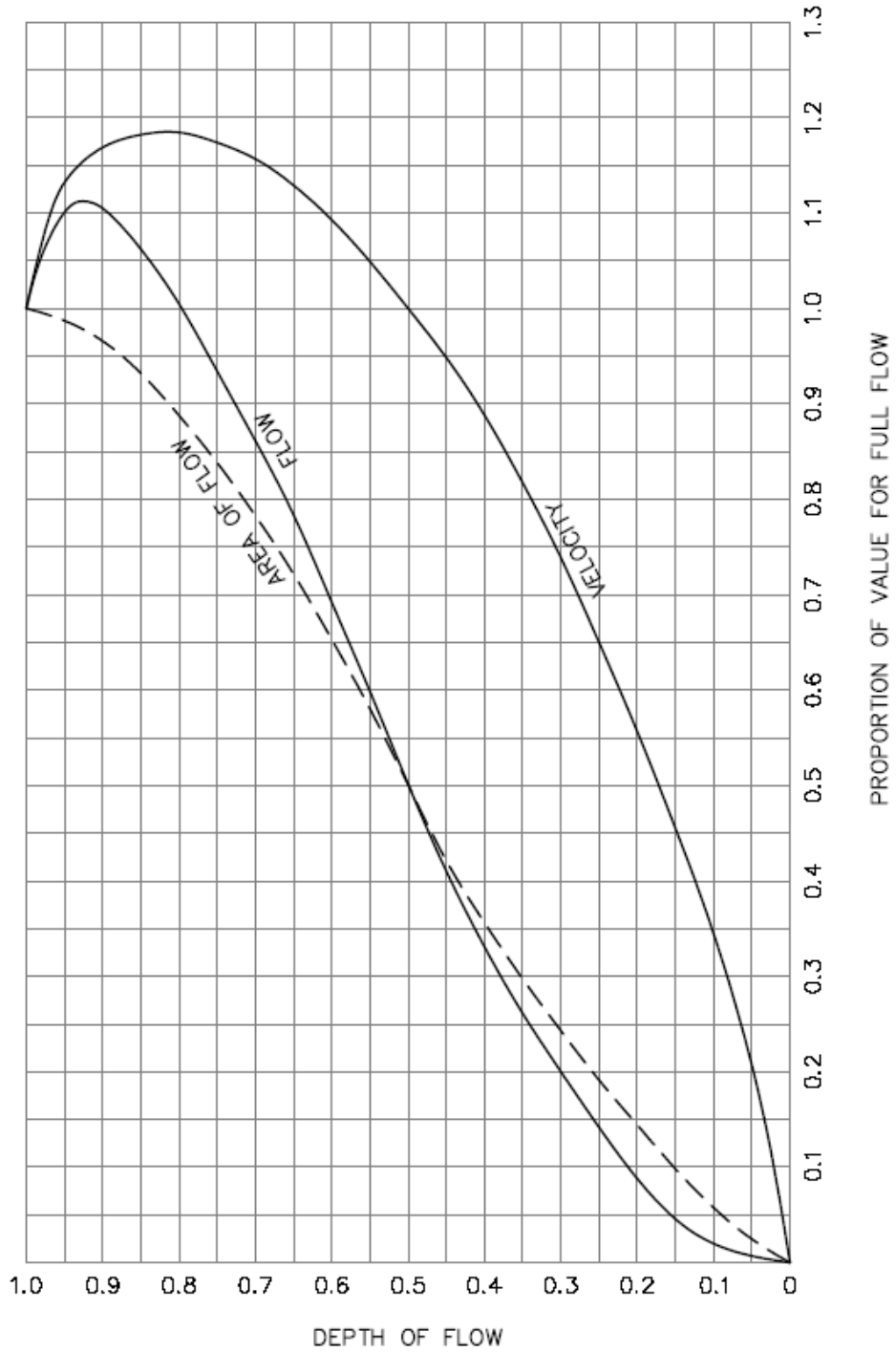

VERSION: April 30, 2009

WTC ENGINEERING, INC.

REFERENCE:
ACPA, *Concrete Pipe Design Manual*, 2007

FIGURE
902

HYDRAULIC PROPERTIES OF ARCH PIPE

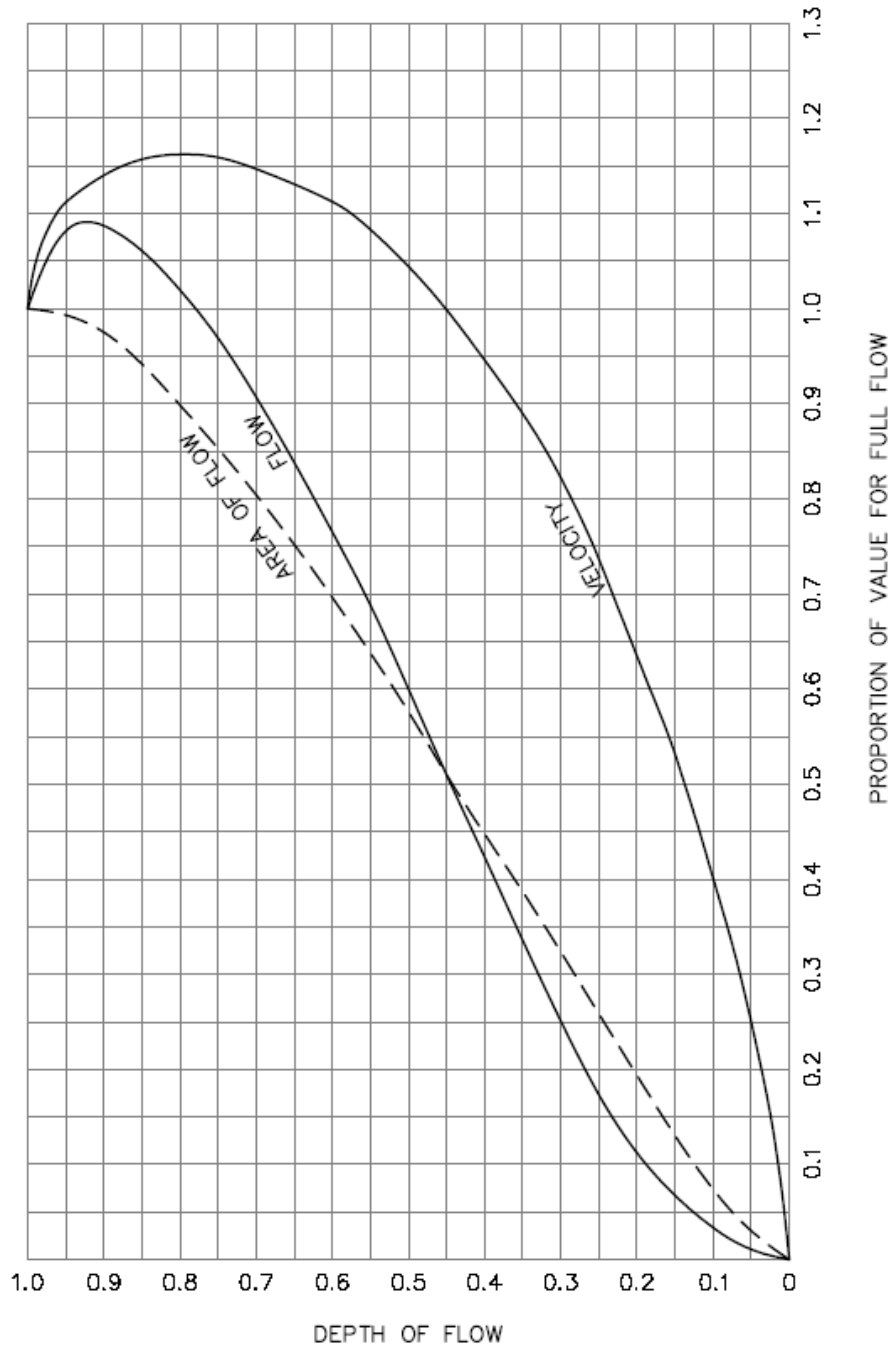

VERSION: April 30, 2009

WTC ENGINEERING, INC.

REFERENCE:
ACPA, *Concrete Pipe Design Manual*, 2007

FIGURE
903

ENERGY LOSS COEFFICIENT IN STRAIGHT THROUGH MANHOLE

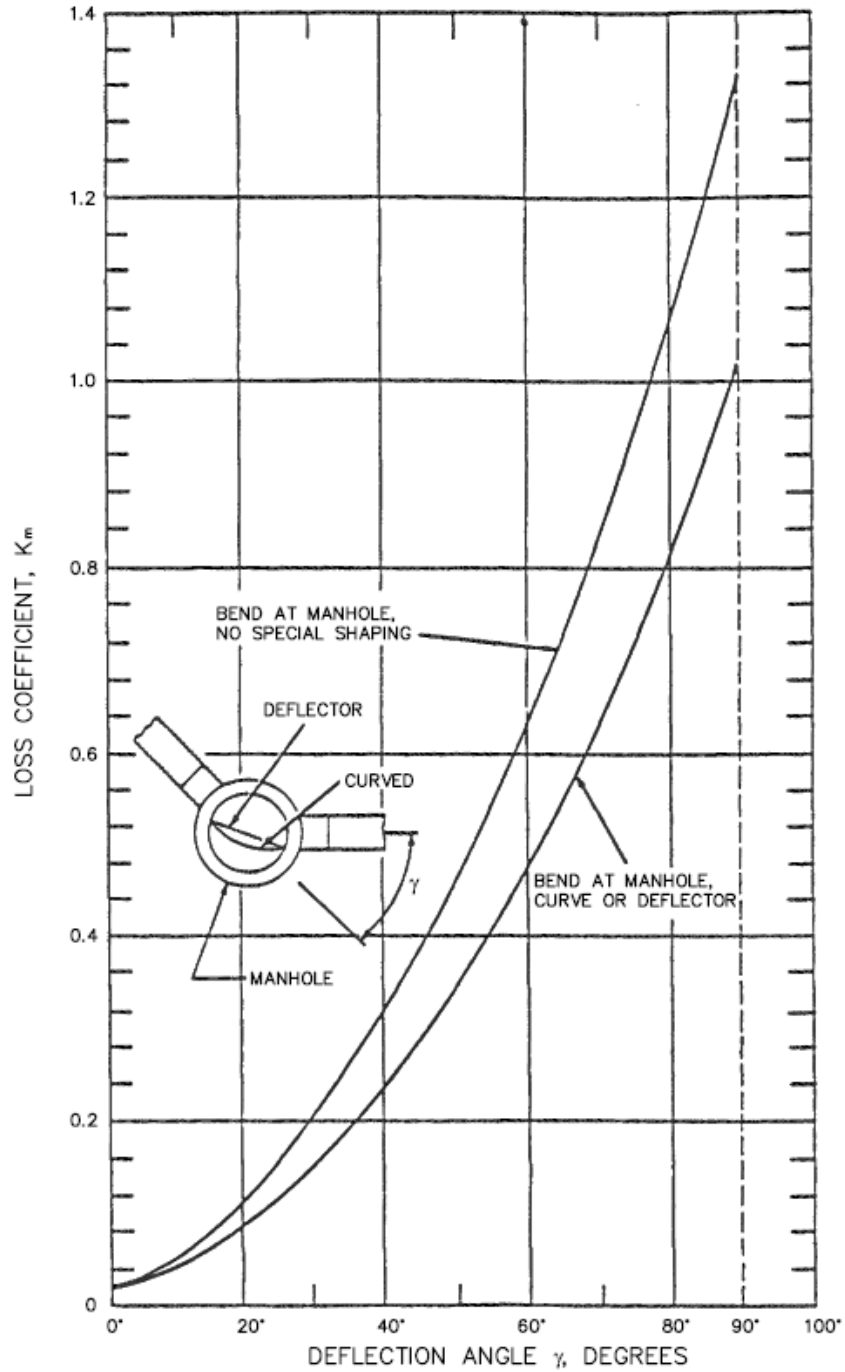

NOTE: HEAD LOSS APPLIED AT OUTLET OF MANHOLE

VERSION: April 30, 2009

REFERENCE:
 AISI, Washington, DC, *Modern Sewer Design*, 1980

FIGURE
 904

WTC ENGINEERING, INC.

EXAMPLE PROBLEM: SCHEMATIC DRAWING STORM SEWER SYSTEM

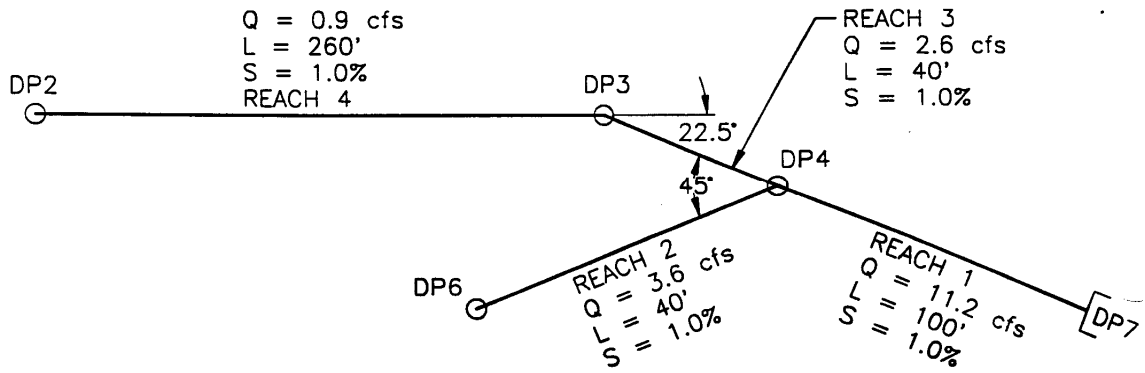

DP: DESIGN POINT

VERSION: April 30, 2009

REFERENCE:

FIGURE
905

WTC ENGINEERING, INC.

EXAMPLE PROBLEM: STORM SEWER PROFILE

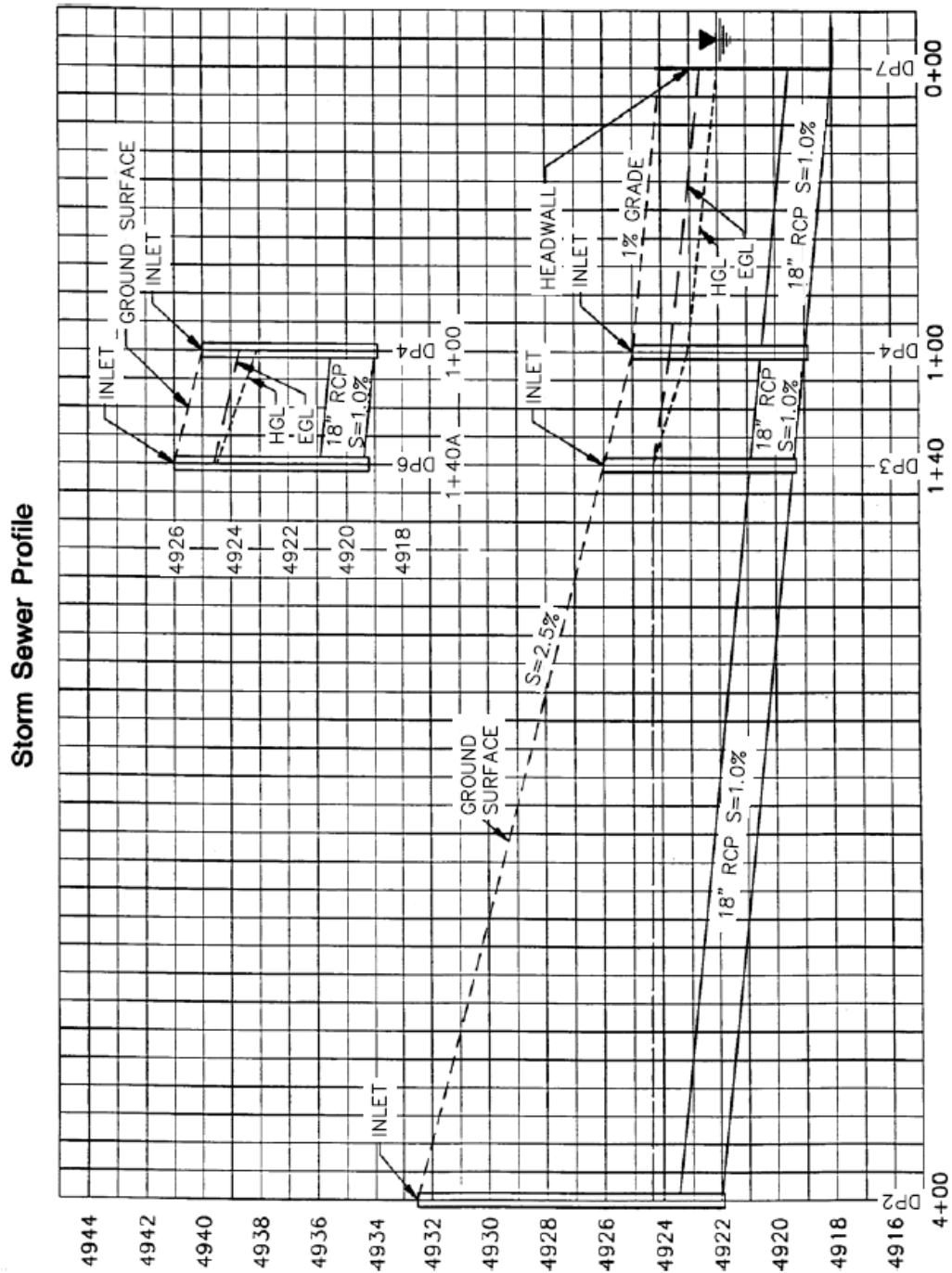

VERSION: April 30, 2009

REFERENCE:

FIGURE
906

WTC ENGINEERING, INC.

TRUCKEE MEADOWS REGIONAL DRAINAGE MANUAL

EXAMPLE PROBLEM: STORM SEWER HYDRAULIC CALCULATIONS

TRUCKEE MEADOWS REGIONAL DRAINAGE MANUAL

STORM SEWER HYDRAULIC CALCULATIONS

PROJECT NUMBER: _____ DAY NO: _____

CONTRACT NO: _____ CALCULATED BY: _____

Station	To	From	CONCRETE DATA			FLOW DATA			SMPPLY LOSS DATA			SMPPLY & HYDRAULIC DATA			CONCRETE					
			Start	End	Length	Shape	Area	Perim	Hyd. Rad.	Flow	Loss	Loss	Loss	Flow	Loss	Loss	Flow	Loss	Loss	
Feet			Feet	Feet	Sq. Ft.	Feet	Feet	Feet	CFS	Feet	Feet	Feet	CFS	Feet	Feet	Feet	CFS	Feet	Feet	
1			100	100	100	100	100	100	100	100	100	100	100	100	100	100	100	100	100	100
2			100	100	100	100	100	100	100	100	100	100	100	100	100	100	100	100	100	100
3			100	100	100	100	100	100	100	100	100	100	100	100	100	100	100	100	100	100
4			100	100	100	100	100	100	100	100	100	100	100	100	100	100	100	100	100	100
5			100	100	100	100	100	100	100	100	100	100	100	100	100	100	100	100	100	100

Version: April 30, 2009 REFERENCE: _____

PLACES - CSI _____

STANDARD FORM 2

SECTION 1000 - STREETS

TABLE OF CONTENTS

	<u>Page</u>
1001 INTRODUCTION	1001
1002 FUNCTION OF STREETS IN THE DRAINAGE SYSTEM.....	1001
1003 DRAINAGE IMPACTS ON STREETS.....	1001
1003.1 SHEET FLOW	1002
1003.2 GUTTER FLOW.....	1002
1003.3 TEMPORARY PONDING	1002
1003.4 CROSS FLOW.....	1002
1004 DRAINAGE IMPACT ON STREET MAINTENANCE.....	1003
1004.1 PAVEMENT DETERIORATION.....	1003
1004.2 SEDIMENTATION AND DEBRIS	1003
1005 STREET CLASSIFICATION AND ALLOWABLE FLOW DEPTH.....	1004
1006 HYDRAULIC EVALUATION.....	1004

SECTION 1000

STREETS

1001 INTRODUCTION

The criteria presented in this section shall be used in the evaluation of the allowable drainage encroachment within public streets. The review of all planning submittals (Section 500) which involve storm flow in streets will be based on the criteria herein.

1002 FUNCTION OF STREETS IN THE DRAINAGE SYSTEM

Urban and rural streets in the Washoe County area having curb and gutter facilities or roadside ditches are part of the Local Drainage System. The streets naturally carry runoff from both the Minor and Major storm events. For design purposes, the streets are allowed to carry runoff in excess of the minor storm (Section 304.2), subject to certain limitations (Section 304.4). When the storm flows in the street exceed allowable limits (Section 304.4), a storm sewer system (Section 900) or an open channel (Section 800) is required to convey the excess flows. The primary function of urban streets is for traffic movement and therefore the drainage functions are subservient and should not interfere significantly with the traffic function of the street.

Design criteria for the collection and conveyance of runoff water on public streets are based on a reasonable frequency and magnitude of traffic interference. That is, depending on the character of the street, certain traffic lanes can be fully inundated during larger storms. During less intense storms, runoff will also inundate traffic lanes but to a lesser degree. The primary drainage function of the streets is to convey Minor storm and nuisance flows quickly and efficiently to the storm sewer or open channel drainage system with minimal interference to traffic movement. For the Major storm event, the function of the streets is to provide an emergency passageway for the flood flows with minimal damage to the urban environment.

1003 DRAINAGE IMPACTS ON STREETS

The following characteristics of storm runoff or drainage patterns can influence the traffic movement function of a street:

1. Sheet flow across the pavement resulting from precipitation runoff
2. Runoff in the gutter
3. Duration of the storm
4. Ponded water
5. Flow across traffic lanes
6. Physical damage to the street

To minimize the impact of storm runoff on streets, each of the above factors must be understood and controlled to within acceptable limits. The effects of the above factors are discussed in the following sections.

1003.1 SHEET FLOW

Rainfall on the paved surface of a street or road must flow overland in what is referred to as sheet flow until it reaches a channel. Streets which have curbs and gutters become the channel, while on roads which have a drainage ditch, the ditch becomes the channel. In situations where the street is not inundated, the depth of sheet flow will be essentially zero at the crown of the street and will increase in the direction of the curb and gutter or drainage ditch.

Traffic interference due to sheet flow is by hydroplaning or by splash. Hydroplaning is the phenomenon of vehicle tires becoming supported by a film of water which acts as a lubricant between the pavement and the vehicle. This generally occurs at higher speeds associated with arterials and freeways and can result in loss of vehicle control. Drainage design can reduce the hydroplaning potential by increasing the street cross slope which drains the runoff more quickly.

Splashing of the sheet flows interferes with traffic movement by reducing visibility. The increase in cross slope of the street crown also reduces the splash potential. In general, a 2 percent cross slope is a desirable practical slope to promote swift removal of runoff while minimizing potential vehicle side-slippage from ice buildup during winter months.

1003.2 GUTTER FLOW

Water which enters a street as sheet flow from the pavement surface or as overland flow from adjacent land area will flow in the gutter and possibly a portion of the street section until reaching some outlet, such as a storm sewer inlet or a channel. As the flow progresses downstream and additional areas contribute to the runoff, the width of flow will increase and progressively infringe upon the traffic lane. If the roadway width allows vehicles to be parked adjacent to the curb, the flow width will have little influence on traffic capacity until it exceeds the width of the parking lane by several feet. However, on streets where parking is not permitted, the flow width significantly effects traffic movement after exceeding a few feet, since the flow encroaches on a moving lane rather than a normal parking lane. Field observations show that vehicles will crowd adjacent lanes to avoid curb flow. This creates a traffic hazard which contributes to the rash of minor accidents that occur during rain storms.

As the flow width increases, the traffic must eventually move through the inundated lanes, progressively reducing traffic movement as the depth of flow increases. Although some reduction of traffic movement caused by runoff is acceptable, emergency vehicles (i.e., fire equipment, ambulances, police vehicles) must be able to travel the streets. Therefore, certain limitations on the depth of flow in the street are required.

1003.3 TEMPORARY PONDING

Storm runoff temporary ponded on the street due to grade changes or intersection street crowns affects traffic movement by increasing flow depths and the duration of flow at the greater depths. This temporary ponding is localized and vehicles may enter the ponded area at high speeds unaware of the ponded water until the vehicle is out of control. Ponding will often cause traffic to halt to avoid vehicle stalling, resulting in reduced traffic movement. Therefore, depths of temporary ponding must be controlled in a manner similar to gutter flow and in some cases eliminated on high traffic volume streets.

1003.4 CROSS FLOW

Whenever storm runoff, other than sheet flow, moves across a traffic lane, traffic movement is affected. The cross flow may be caused by superelevation of a curve, by the intersection of two

streets, by exceeding the capacity of the higher gutter on a street with cross fall, or simply poor street design. The problem associated with this type of flow is the same as for ponding in that it is localized in nature and vehicles may be traveling at high speed when they reach the location. If the speed limits are slow and the traffic volume is light, then the influence of cross street flow may be within acceptable limits.

1004 DRAINAGE IMPACT ON STREET MAINTENANCE

The use of the roadway system for drainage of runoff during and immediately after storm events also has an impact on the structural integrity of the pavement system and the roadway maintenance required. If water penetrates the road surface and saturates the sub-grade material, the sub-grade may fail and cause failure of the pavement.

Additionally, runoff from rural and urban areas can carry large amounts of debris and sediment, which may reduce the performance of hydraulic structures or become a safety hazard, which must be removed.

1004.1 PAVEMENT DETERIORATION

The efficient removal of storm runoff from pavement surfaces has a positive effect on street maintenance and repair. Street maintenance and repair procedures can in turn affect the efficiency of a street as part of the runoff collection system. Research has indicated that pavement deterioration is accelerated by the presence of storm runoff.

Pavement surfaces are subject to numerous types of distress such as weathering, raveling, long cracks, alligator cracks, chuck holes, bleeding, depression, and edge breakup. Water is probably the greatest cause of distress in a pavement structure. Flow of water across a bituminous pavement surface has little effect on the pavement so long as the pavement retains its watertight condition. A number of types of pavement distress may cause the pavement to become permeable, allowing water to reach the sub-grade. Once the water reaches the sub-grade, the problems multiply as the sub-base and sub-grade weaken, causing an increase in cracks through the surface.

A common practice to reduce the problem of bituminous surface deterioration is to seal-coat or overlay the surface. This reduces the problem of pavement deterioration, but indirectly creates a problem with the carrying capacity of the adjacent gutter. As the street section is resurfaced, the flow area of the section is decreased. Over a period of 20 to 30 years, a considerable portion of the runoff carrying capacity of the street may be lost. Scarifying the surface to remove the upper layer of asphalt prior to resurfacing reduces the problem, but is not always the selected method. In any case, the street section flow capacity should be maintained.

1004.2 SEDIMENTATION AND DEBRIS

A common problem in the Washoe County area is the deposition of sediment and debris on the street surface during and after a storm event. During the flow event, this sedimentation can cause problems by reducing the flow carrying capacity of the street section and causing increased encroachment into the traffic lanes. This problem is most prevalent at major grade changes where the flow velocity in the street section is reduced. Reducing the flow velocity decreases its sediment and debris transport ability and sediment and debris is deposited.

Additionally, sediment and other debris carried by runoff can impair the operation of hydraulic structures such as curb inlets and grated drop inlet structures. The sediment and debris can block a portion of the flow area into these facilities and cause artificially increased water surface elevations.

Immediately after a storm event, identified problem areas should be reviewed and street sweeping initiated to remove accumulated sediment and debris. By regularly scheduled sweeping of upstream areas, the source of some of the sediment can be eliminated. Also, runoff from construction sites may cause site-specific sedimentation problems and shall be controlled as per Section 1400.

1005 STREET CLASSIFICATION AND ALLOWABLE FLOW DEPTH

The streets in each jurisdiction are classified according to traffic volume and right-of-way width. The standard street sections are provided by the individual Jurisdictional Entities. The street classifications, right-of-way (ROW) requirements, and allowable storm flow depth criteria are provided in Policy Section 304.4.

The calculation of the water surface elevation and velocity must be based on limiting the flow to the width of the ROW. This implies that, for calculation purposes only, an infinitely high vertical wall exists at the ROW boundary and any flow area outside of the right-of-way is not considered in the analysis. This provides a conservative analysis for street capacity requirements. In addition, whenever flow depths are such that crown overtopping would occur, the one-half street calculations assume a vertical wall at the street crown with no associated wetted perimeter.

For street sag locations, provisions must be included to carry the 100-year runoff in a pipe or an overflow section and include an access and maintenance easement.

1006 HYDRAULIC EVALUATION

The hydraulic analysis of flow in street sections is similar to open channel flow analysis for larger flood control channels (Section 800). The basic governing equation, Manning's equation, is as follows:

$$Q = \left(\frac{1.49}{n} \right) AR^{2/3} S^{1/2} \quad (1001)$$

where

- Q = discharge (cfs)
- n = roughness coefficient (0.016 for streets)
- A = flow area (square feet)
- R = hydraulic radius = A/P (feet)
- P = wetted perimeter (feet)
- S = slope of the energy grade line (EGL), generally assumed equal to the street slope (ft/ft)

Based upon the policy of Section 304.4, the allowable storm capacity of the minor storm of each street section is calculated using Equation 1001.

The calculation of depth of flow for the major storm event is also based on Equation 1001. The major difference is in the assumed flow area. For the calculation of flow depth and velocity, the area outside the limits of the right-of-way is not considered in the calculation of conveyance. Even though water will flow in the area outside of the right-of-way, the depth of flow allowed is based on containment of the flow within the right-of-way.

Streets with grades flatter than 0.5% must be given special consideration when calculating allowable flow depth. These streets are subject to ponding and are candidates for storm sewers. Storm sewers and their inlets are described in Section 900.

SECTION 1100 - CULVERTS AND BRIDGES

TABLE OF CONTENTS

	<u>Page</u>
1101 INTRODUCTION	1102
1102 DESIGN STANDARDS FOR CULVERTS	1102
1102.1 CULVERT SIZING CRITERIA	1102
1102.2 CONSTRUCTION MATERIALS	1102
1102.3 VELOCITY LIMITATIONS AND INLET/OUTLET PROTECTION.....	1103
1102.4 HEADWATER CRITERIA	1103
1102.5 ALIGNMENT	1104
1102.6 TEMPORARY CROSSING	1104
1102.7 MULTIPLE-BARREL CULVERTS	1104
1102.8 TRASH RACKS/SAFETY GRATES.....	1105
1102.9 AIR VENTS	1105
1102.10 MAINTENANCE ACCESS	1105
1103 CULVERT HYDRAULICS	1105
1103.1 INLET CONTROL CONDITION	1106
1103.2 OUTLET CONTROL CONDITION	1106
1103.3 HYDRAULIC DATA	1107
1103.4 STRUCTURAL DESIGN	1107
1104 DESIGN STANDARDS FOR BRIDGES.....	1108
1104.1 BRIDGE SIZING CRITERIA	1108
1104.2 VELOCITY LIMITATIONS	1108
1105 BRIDGE HYDRAULICS.....	1108
1105.1 HYDRAULIC ANALYSIS	1108
1105.2 INLET AND OUTLET CONFIGURATION	1108
1106 EXAMPLE APPLICATION	1108
1106.1 EXAMPLE: CULVERT SIZING	1108

LIST OF TABLES

1101	HYDRAULIC DATA FOR CULVERTS – CULVERT ENTRANCE LOSSES
------	---

LIST OF FIGURES

- 1101 CULVERT ALIGNMENT
- 1102 CULVERT FLOW TYPES
- 1103 NOMOGRAPH – INLET CONTROL BOX CULVERT
- 1104 NOMOGRAPH – INLET CONTROL RCP
- 1105 NOMOGRAPH – INLET CONTROL ELLIPTICAL PIPE
- 1106 OUTLET CONTROL CULVERT HYDRAULICS
- 1107 NOMOGRAPH – CRITICAL DEPTH
- 1108 NOMOGRAPH – CRITICAL DEPTH
- 1109 NOMOGRAPH – CRITICAL DEPTH
- 1110 NOMOGRAPH – OUTLET CONTROL BOX CULVERT
- 1111 NOMOGRAPH – OUTLET CONTROL RCP
- 1112 NOMOGRAPH – OUTLET CONTROL ELLIPTICAL PIPE
- 1113 EXAMPLE: NOMOGRAPH – INLET CONTROL 5-FOOT DIAMETER RCP
- 1114 EXAMPLE: NOMOGRAPH – CRITICAL DEPTH – CIRCULAR PIPE - 5-FOOT DIAMETER RCP
- 1115 EXAMPLE: NOMOGRAPH – OUTLET CONTROL RCP ($n = 0.012$) - 5-FOOT DIAMETER RCP

SECTION 1100

CULVERTS AND BRIDGES

1101 INTRODUCTION

Culverts and bridges are used to convey water through or beneath engineered structures. The size, alignment, and support structures of a bridge or culvert will directly affect the carrying capacity of the drainage system. Inadequate culvert or bridge capacity can force water out of the conveyance system, causing the flood water to take an alternate path and causing damage away from the conveyance system.

The primary distinction between a culvert and a bridge is the change in flow area from the upstream channel cross-section. A culvert is usually designed to allow the design upstream water surface elevation to be greater than the top of the culvert, while bridge design generally provides freeboard between the design flood water surface and the low chord of the bridge.

1102 DESIGN STANDARDS FOR CULVERTS

All culverts within the Washoe County area shall be designed and constructed using the following standards. The analysis and design shall consider design flow, culvert size and material, upstream channel and entrance configuration, downstream channel and outlet configuration, and erosion protection.

1102.1 CULVERT SIZING CRITERIA

For hydraulic analysis, sizing of culverts is important because of potential effects on water surface elevations in a channel. Larger culverts do not encroach into the channel cross-section as much as smaller culverts and will cause a smaller rise in water surface elevations. The trade-off is that larger culverts are more expensive to construct than small culverts.

1102.1.1 DESIGN FREQUENCY

As indicated in Policy Section 304.5, all culverts, including driveway culverts and overflow sections where permitted, will be designed to pass the flow from the major storm.

1102.1.2 MINIMUM SIZE

The minimum culvert size shall be 18-inch diameter for round pipe or shall have a minimum flow area of 2.2 square feet for other pipe shapes.

Culverts for driveways for single family residences shall be sized for the equivalent roadside ditch flow area and be a minimum 12-inch diameter round pipe or equivalent pipe size for other than round pipe.

1102.2 CONSTRUCTION MATERIALS

Culverts shall be constructed with Reinforced Concrete Pipe. The pipe shape may be round, square, rectangular, or elliptical.

Other pipe materials may be used for culvert construction upon approval by the Jurisdictional Entity. Documentation must be submitted for review which shows that the subject pipe material has a design life similar to the above materials and that the interior lining, if any, will maintain the design Manning's roughness coefficient ("n") value for the life of the pipe material.

Culvert headwalls and wingwalls shall be provided with guardrails or handrails in conformance with local building codes and roadway design safety requirements.

1102.3 VELOCITY LIMITATIONS AND INLET/OUTLET PROTECTION

In the proper design of culverts, the velocity of the flow through the culvert is very important. If the velocity is too low, suspended sediment in the flow may settle. This decreases the effective area of the culvert and increases the frequency of required maintenance. If the velocity of the flow exiting the culvert is too high, erosion may take place, possibly jeopardizing the integrity of the culvert and roadway.

All culverts shall include headwalls/wingwalls or flared-end sections at inlets and outlets. Culvert designs which include road overtopping sections shall include a road profile which will adequately confine flows within the design overtopping section and convey such flows into the downstream channel. Adequate erosion protection shall be provided to prevent degradation of the roadway and embankments.

All culverts shall be designed to provide a minimum flow velocity of 3 fps at the culvert outlet under minor storm conditions. In addition, the culvert slope shall be a minimum 0.25 percent. Where these two conditions cannot be met due to constraints, design approval must be obtained from the Jurisdictional Entities.

The criteria for outlet erosion protection for discharges to channels with unlined bottoms are as follows:

<u>Outlet Velocity (fps)</u>	<u>Required Outlet Protection</u>
less than 5	Minimum riprap protection (Section 807.3)
between 5 and 15	Riprap protection (Section 807.3) or Energy dissipator (Section 1202.2)
greater than 15	Energy dissipator (Section 1202.2)

1102.4 HEADWATER CRITERIA

For culvert designs based on standard inlet (headwall, wingwalls, etc.) and outlet configurations, the maximum headwater for the design storm flow for culverts greater than 36-inch diameter or a culvert rise of greater than 36 inches shall be 1.5 times the culvert height. The maximum headwater for culverts with a height of 36 inches or less shall be 5 feet if adjacent properties are not adversely affected.

If site conditions are such that the maximum headwater conditions can not be met, additional engineering analysis shall be performed. This analysis is necessary to determine scour potential, embankment stability and any other factors that may influence the long-term stability of the structure. Additional erosion protection around the culvert inlet or other design considerations shall be included as appropriate to ensure the long-term stability of the culvert and approaches.

Culverts which do not include an overtopping section shall have a minimum of 1 foot freeboard from the hydraulic grade line elevation at the culvert entrance to the edge of the overlying roadway. Levees shall not be used to provide increased headwater at culvert inlets.

The extent of impact on adjacent properties from backwater created by culvert installations shall be analyzed for all culverts.

1102.5 ALIGNMENT

The alignment of the culvert with respect to the natural channel is very important for proper hydraulic performance. Culverts may pass beneath the roadway normal to the centerline or they may pass at an angle (skewed). Whenever possible, culverts should be aligned with the natural channel. This reduces inlet and outlet transition problems.

Where the natural channel alignment would result in an exceptionally long culvert, modification to the natural alignment may be necessary. Since such modifications will change the natural stability of the channel, such modification should be thoroughly investigated. Although the economic factors are important, the hydraulic effectiveness and stability of the culvert must be the major consideration. Improper culvert alignment may cause erosion to adjacent properties or siltation of the culvert. Culvert alignment considerations are shown in Figure 1101.

Roadway alignment also affects culvert design. The vertical alignment of roadways may define the maximum culvert diameter that can be used. Low vertical clearance may require the use of elliptical or arched culverts, or the use of a multiple-barrel culvert system. All culverts shall have a minimum of 1.5 feet of cover from top of asphalt (or gravel for gravel road) to outside top of pipe. Culverts for which 1.5 feet of cover is unavailable will require additional structural analysis and other provisions (i.e. full depth concrete paving to compensate for the loss of proper cover).

1102.6 TEMPORARY CROSSING

Temporary crossings are defined as dip road sections with a culvert sized to pass nuisance flow, or a culvert system that does not meet criteria presented in Section 1100 of this Manual.

Temporary crossings will be reviewed on a case-by-case basis. Major consideration will be given to the following items:

1. Drainage area contributing to crossing
2. Volume of roadway traffic
3. Vertical and horizontal roadway alignment (sight distance)
4. Alternate access routes
5. Time frame for temporary crossing
6. Current and projected development density
7. 5-year and 100-year storm flows

1102.7 MULTIPLE-BARREL CULVERTS

If the available fill height limits the size of culvert which is necessary to convey the flood flow, multiple culverts can be used. If each barrel of a multiple-barrel culvert is of the same type and size and constructed such that all hydraulic parameters are equal, the total flow should be assumed to be equally divided among each of the barrels.

1102.8 TRASH RACKS/SAFETY GRATES

During culvert design, engineering judgment shall be used to determine if trash racks or safety grates should be included. Factors which may influence whether or not trash racks or safety grates should be used include the following:

- Tributary land use (urban, rural, forest)
- Location (urban/rural)
- Design flow
- Size of culvert
- Anticipated debris loading
- Performance of nearby existing structures

Additionally, trash racks or safety grates shall be used for all culverts located adjacent to schools, parks, playgrounds and other recreational facilities where the pipe alignment or length does not allow for an unobstructed view through the culvert. The open area through the grate at the design water surface shall be four times the design flow area of the culvert or in lieu of this; a trash rack/entrance section design provided in the Standard Specifications for Public Works Construction shall be used.

1102.9 AIR VENTS

All culverts greater than 48 inches in diameter, for which both the inlet and outlet are sealed by water under less than full flow conditions, shall include an air vent pipe to prevent air accumulation/partial vacuums. Said vent shall have a diameter equal to or greater than one-sixth of the culvert pipe diameter.

1102.10 MAINTENANCE ACCESS

Access (including necessary easements) for culvert maintenance/cleaning shall be provided at all culvert locations.

1103 CULVERT HYDRAULICS

This section presents the general procedures for hydraulic design and evaluation of culverts. The user is assumed to possess a basic working knowledge of culvert hydraulics and is encouraged to review textbooks and other technical literature on the subject.

The two categories of flow in culverts are inlet control and outlet control. Under inlet control, the flow through the culvert is controlled by the headwater on the culvert and the inlet geometry. Under outlet control, the flow through the culvert is controlled primarily by culvert slope, roughness, and tailwater elevation.

When designing a culvert, the designer must evaluate both inlet and outlet control conditions for the given design constraint (e.g. headwater depth, flow capacity, etc.). The control condition which produces the greater energy loss for the design condition determines the appropriate control to use for culvert design. Culvert hydraulic calculations shall be performed using rating nomographs and/or culvert hydraulic analysis programs (i.e. HY-8).

1103.1 INLET CONTROL CONDITION

Inlet control for culverts may occur in two ways (see Figure 1102):

1. Unsubmerged - The headwater is not sufficient to submerge the top of the culvert and the culvert invert slope is supercritical. The culvert entrance acts like a weir (Condition A, Figure 1102).
2. Submerged - The headwater submerges the top of the culvert but the pipe does not flow full. The culvert inlet acts like an orifice (Condition B and C, Figure 1102).

The inlet control rating for typical shapes and inlet configurations are presented in Figures 1103 to 1105. Additional nomographs are available in the U.S. Department of Transportation's Hydraulic Design Series Number 5 (USDOT, 1985). These nomographs were developed empirically by pipe manufacturers, Bureau of Public Roads, and the Federal Highway Administration. The nomographs shall be used in the Washoe County area rather than the orifice and weir equations, due to the uncertainty in estimating the orifice and weir coefficients.

1103.2 OUTLET CONTROL CONDITION

Outlet control will govern if the headwater and/or tailwater is deep enough, the culvert slope is relatively flat, and the culvert is relatively long. There are three types of outlet control culvert flow conditions:

1. The headwater submerges the culvert top, and the culvert outlet is submerged by the tailwater. The culvert will flow full (Condition A, Figure 1102).
2. The headwater submerges the top of the culvert and the culvert is unsubmerged by the tailwater (Condition B or C, Figure 1102).
3. The headwater is insufficient to submerge the top of the culvert. The culvert slope is subcritical and the tailwater depth is lower than the pipe critical depth (Condition D, Figure 1102).

The factors affecting the capacity of a culvert in outlet control include the headwater elevation, the inlet geometry and associated losses, the culvert material friction losses, and the tailwater condition.

The capacity of the culvert is calculated using the conservation of energy principle (Bernoulli's Equation). An energy balance exists between the total energy of the flow at the culvert inlet and at the culvert outlet, which includes the inlet losses, the friction losses, and the velocity head (see Figure 1106). The equation is then expressed as:

$$H = h_e + h_f + h_v \tag{1101}$$

where	<table style="border: none;"> <tr> <td style="padding-right: 10px;">H</td> <td style="padding-right: 10px;">=</td> <td>total energy difference, inlet through outlet (ft)</td> <td></td> </tr> <tr> <td style="padding-right: 10px;">h_e</td> <td style="padding-right: 10px;">=</td> <td>entrance head losses (ft)</td> <td></td> </tr> <tr> <td style="padding-right: 10px;">h_f</td> <td style="padding-right: 10px;">=</td> <td>friction losses (ft)</td> <td></td> </tr> <tr> <td style="padding-right: 10px;">h_v</td> <td style="padding-right: 10px;">=</td> <td>velocity head = V²/2g (feet)</td> <td style="vertical-align: bottom;">(1102)</td> </tr> </table>	H	=	total energy difference, inlet through outlet (ft)		h _e	=	entrance head losses (ft)		h _f	=	friction losses (ft)		h _v	=	velocity head = V ² /2g (feet)	(1102)
H	=	total energy difference, inlet through outlet (ft)															
h _e	=	entrance head losses (ft)															
h _f	=	friction losses (ft)															
h _v	=	velocity head = V ² /2g (feet)	(1102)														

For inlet losses, the governing equation is:

$$h_e = K_e(V^2 / 2g) \tag{1103}$$

where k_e is the entrance loss coefficient. Typical entrance loss coefficients recommended for use are given in Table 1101.

Friction loss is the energy required to overcome the roughness of the culvert and is expressed as follows:

$$h_f = (29n^2L/R^{1.33})(V^2/2g) \quad (1104)$$

where

n	=	Manning's coefficient (see Table 1102)
L	=	Length of culvert (ft)
R	=	Hydraulic radius (ft)
V	=	Velocity of flow (fps)
G	=	Gravitational acceleration constant (32.2 ft/s ²)

Substituting equivalent terms from Equations 1102, 1103, and 1104 into Equation 1101 and simplifying the terms results in the following equation:

$$H = [K_e + (29n^2L/R^{1.33}) + 1]V^2/2g \quad (1105)$$

Equation 1105 can be used to calculate the culvert capacity directly when the culvert is flowing under outlet control conditions A or B as shown on Figure 1102. The actual headwater (H_w) is calculated by adding H to the tailwater elevation (see Figure 1106). For conditions C or D in Figure 1102, the hydraulic grade line at the outlet is approximated by averaging the critical depth and the culvert diameter. This value is used to compute headwater depth (H_w) if it is greater than the tailwater depth (T_w). This is an approximate method and is more fully described in HDS No. 5 (USDOT, 1985). Estimates of critical depth for box culverts, circular pipe, and elliptical pipe can be obtained from Figures 1107, 1108, and 1109 respectively.

A series of outlet control nomographs for various culvert shapes have been developed by pipe manufacturers, Bureau of Public Roads, and the Federal Highway Administration. The nomographs are presented in Figures 1110 to 1112. Additional nomographs are available in HDS No. 5 (USDOT, 1985). When rating a culvert, either the outlet control nomographs or Equation 1105 can be used to calculate the headwater requirements.

1103.3 HYDRAULIC DATA

The hydraulic data provided in Table 1101 shall be used in the hydraulic design of all culverts within the Washoe County area. The design capacity of culverts shall be calculated using the computation sheet provided as Standard Form 4. Manning's roughness coefficients ("n") used for velocity and capacity calculations shall be those presented in Table 901 for storm sewers.

Alternatively, computer programs may be used for hydraulic analysis. However the designer should thoroughly review the modeling results to determine if the analysis has properly modeled the hydraulic conditions.

1103.4 STRUCTURAL DESIGN

All culverts shall be designed as a minimum to withstand an HS-20 loading in accordance with the Load and Resistance Factor Design (LRFD) Bridge Design Specifications by AASHTO "Standard Specifications for Highway Bridges" and with the pipe manufacturer's recommendations.

1104 DESIGN STANDARDS FOR BRIDGES

All bridges shall be in accordance with the Load and Resistance Factor Design (LRFD) Bridge Design Specifications by AASHTO and the "Standard Plans for Road and Bridge Construction" by the State of Nevada Department of Transportation. Hydraulic design and analysis shall be in accordance with the following criteria.

1104.1 BRIDGE SIZING CRITERIA

All bridges within the Washoe County area shall be designed to pass the 100-year design flow. Additionally, the design water surface elevation within the bridge shall be a minimum of 2 feet below the bridge low chord. Additional freeboard may be required for special hydraulic conditions. In special flood hazard areas, the bridge shall not back up the 100-year storm flow greater than 1 foot above the natural water surface elevation without mitigation measures. The designer must also ensure that no adjacent properties are adversely affected. Design freeboard of less than 2 feet must be approved by the Jurisdictional Entities, with consideration given to debris, change in upstream HGL created by pressure flow conditions, hydraulic forces on the structure and backwater conditions.

1104.2 VELOCITY LIMITATIONS

The velocity limitations through the bridge opening are controlled by the potential scour and subsequent erosion protection provided. Flow velocities through the bridge and approaches shall be in accordance with the appropriate allowable channel velocities as discussed in Section 803.3, dependent on channel lining type.

1105 BRIDGE HYDRAULICS

1105.1 HYDRAULIC ANALYSIS

The procedures for analysis and design as outlined in the publications "Stream Stability at Highway Structures, HEC-20" (USDOT, 2001) and "Evaluating Scour at Bridges, HEC-18" (USDOT, 2001) and Bridge Scour and Stream Instability Countermeasures, HEC-23 (USDOT, 2001) shall be used for the hydraulic design and scour analysis of all bridges in the Washoe County area. This analysis shall be supplemented by an appropriate backwater analysis (see Section 802) to verify the resulting hydraulic performance. The extent of the bridge backwater shall be shown on a topographic map.

Analysis shall be prepared for the design flow condition as well as an approximate 500-year condition (1.7 times the 100-year flow may be used if no better data are available) and the flow condition at which the water surface just inundates the bridge soffit.

1105.2 INLET AND OUTLET CONFIGURATION

The design of all bridges shall include adequate wingwalls to aid in flow transition and help prevent abutment scour and provide slope stabilization from the embankment to the channel. Scour protection on the upstream and downstream abutment transition slopes shall be provided to protect the channel from the erosive forces of eddy currents.

1106 EXAMPLE APPLICATION

1106.1 EXAMPLE: CULVERT SIZING

Problem: Determine the culvert size necessary to convey the 100-year, 24-hour peak flow in Doe Creek beneath John Boulevard.

Top of road elevation = 4928 feet
 Culvert inlet elevation = 4920 feet
 Culvert outlet elevation = 4918 feet
 Culvert length = 200 feet
 Inlet - Groove end with headwall and wingwalls at 45°
 Outlet - Groove end with headwall and wingwalls at 45°
 Flow = 191 cfs from Section 700
 Tailwater Depth = 4 feet

Solution:

Step 1: Assume a pipe diameter or box culvert dimensions and determine the headwater to depth ratio for inlet control conditions using Figure 1104. Assuming a 5-foot diameter reinforced concrete pipe (RCP), the headwater to depth ratio, is 1.38 (see Figure 1113).

Step 2: Calculate the headwater assuming inlet control conditions. Multiply the pipe diameter times the headwater to depth ratio.

$$\text{Headwater} = HW_1 = D(HW/D) = 5(1.38) = 6.9 \text{ feet}$$

Step 3: Estimate the critical depth, d_c , in the culvert from Figure 1108 (see Figure 1114)

$$d_c = 3.9 \text{ feet}$$

Step 4: Since the tailwater depth is less than the culvert diameter, compute the estimated water depth at the culvert outlet assuming the tailwater does not control the outlet conditions.

$$\text{Outlet Depth} = \frac{d_c + D}{2} = \frac{3.9 + 5.0}{2} = 4.5 \text{ feet}$$

Step 5: Determine the flow depth at the culvert outlet, h_o . The estimated depth is the maximum value of the tailwater depth and the water depth assuming no tailwater.

$$h_o = 4.5 \text{ feet}$$

Step 6: Estimate the head, H, for outlet control conditions from Figure 1111

$$H = 2.6 \text{ feet (see Figure 1115)}$$

Step 7: Calculate the headwater depth for outlet control conditions

$$HW_o = H + h_o + LS_o = 2.6 + 4.5 - 2.0 = 5.1$$

where L = Length of culvert (ft)
 S_o = Slope of culvert

Step 8: Determine if the culvert is under inlet control or outlet control and provide the resulting headwater depth and elevation

Since $HW_1 \geq HW_o$ ($6.9 \geq 5.1$), the culvert is under inlet control.

$$HW = 6.9$$

Step 9: Calculate the outlet velocity by an appropriate method and determine the type of outlet protection needed in Section 800

$$V = 10.0 \text{ fps}$$

Riprap protection or an energy dissipator is necessary.

References

AASHTO - *Load and Resistance Factor Design (LRFD) Bridge Design Specifications* (American Association of State Highway and Transportation Officials).

USDOT, 1985 - *Hydraulic Design of Highway Culverts, Hydraulic Design Series No. 5* (US Department of Transportation, Federal Highway Administration, McLean, Virginia, September 1985).

USDOT, 2001 – *Stream Stability at Highway Structures No. 20* (US Department of Transportation, Federal Highway Administration, 2001).

USDOT, 2001 – *Evaluating Scour at Bridges, Hydraulic Engineering Circular No. 18* (US Department of Transportation, Federal Highway Administration, 2001).

**HYDRAULIC DATA FOR CULVERTS
CULVERT ENTRANCE LOSSES**

Type of Entrance	Entrance Coefficient, Ke
<u>Pipe</u>	
Headwall	
Grooved edge	0.20
Rounded edge (0.15D radius)	0.15
Rounded edge (0.25D radius)	0.10
Square edge (cut concrete and CMP)	0.40
Headwall & 45° Wingwall	
Grooved edge	0.20
Square edge	0.35
Headwall with Parallel Wingwalls spaced 1.25D apart	
Grooved edge	0.30
Square edge	0.40
Beveled edge	0.25
Projecting Entrance	
Grooved edge (RCP)	0.25
Squared edge (RCP)	0.50
Sharp edge, thin wall (CMP)	0.90
Sloping Entrance	
Mitered to conform to slope	0.70
Flared-end Section	0.50
<u>Box, Reinforced Concrete</u>	
Headwall Parallel to Embankment (no wingwalls)	
Square edge on 3 edges	0.50
Rounded on 3 edges to radius of 1/12 barrel dimension	0.20
Wingwalls at 30° to 75° to Barrel	
Square edge at crown	0.40
Crown edge rounded to radius of 1/12 barrel dimension	0.20
Wingwalls to 10° to 30° to Barrel	
Square edge at crown	0.50
Wingwalls Parallel (extension of sides)	
Square edge at crown	0.70

NOTE: The entrance loss coefficients are used to evaluate the culvert or sewer capacity operating under outlet control.

VERSION: April 30, 2009	REFERENCE: USDCE, DRCOG, 1969	TABLE 1101
WTC ENGINEERING, INC.		

CULVERT ALIGNMENT

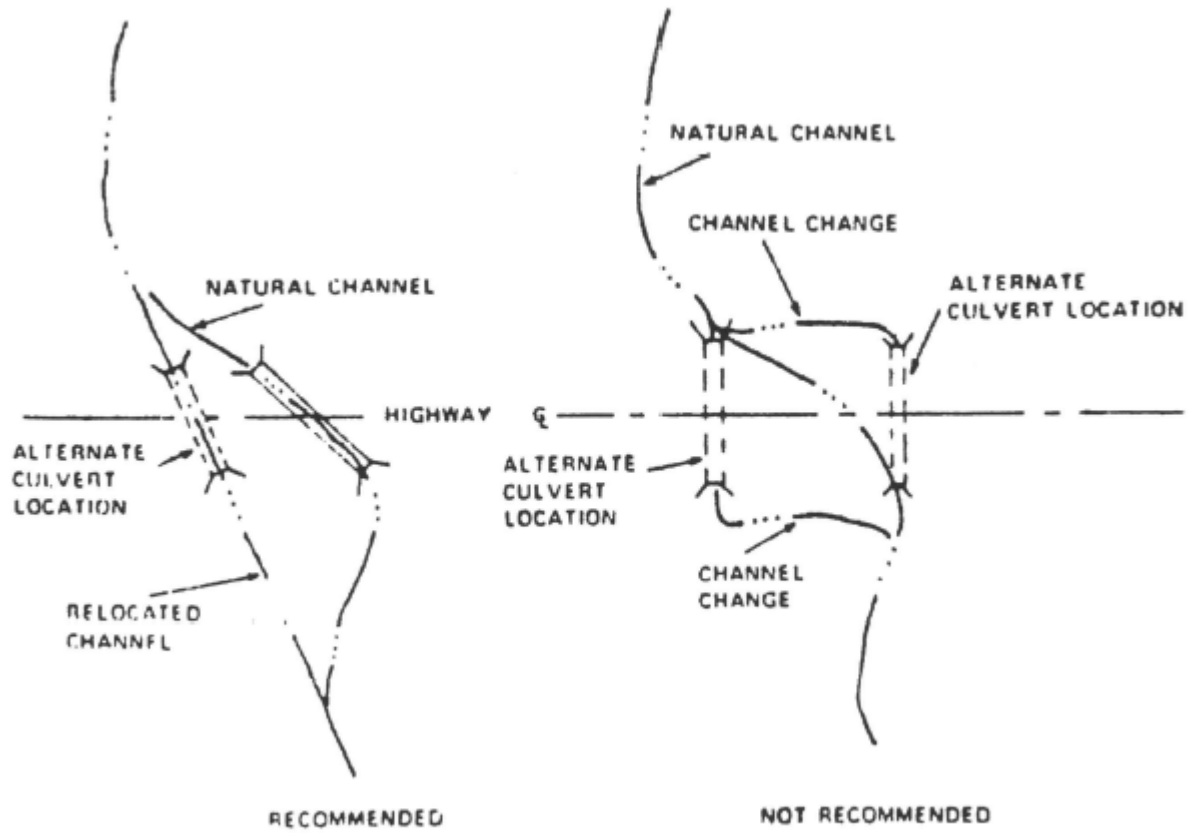

VERSION: April 30, 2009

REFERENCE:

FIGURE
1101

WTC ENGINEERING, INC.

CULVERT FLOW TYPES

INLET CONTROL

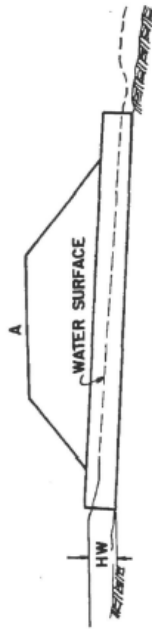

OUTLET UNSUBMERGED

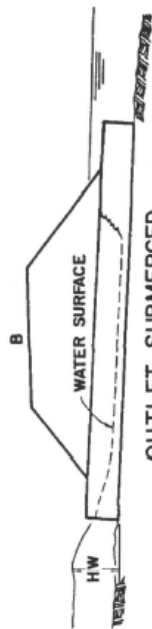

OUTLET SUBMERGED
INLET UNSUBMERGED

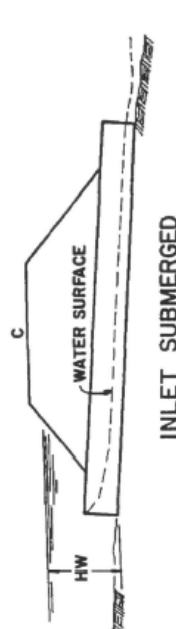

INLET SUBMERGED

OUTLET CONTROL

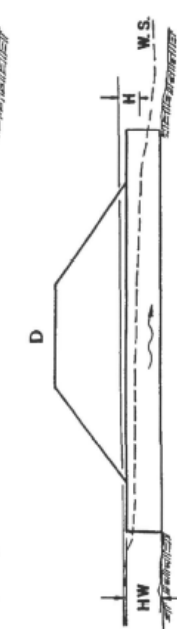
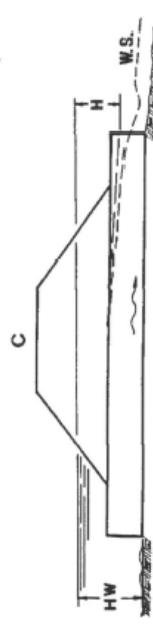
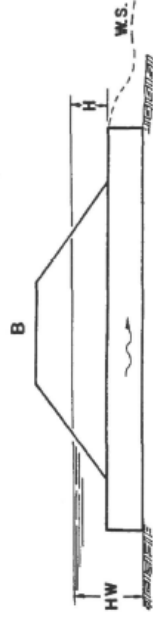
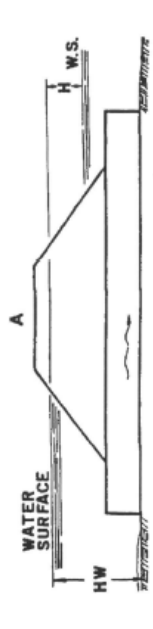

VERSION: April 30, 2009

REFERENCE:

FIGURE
1102

WTC ENGINEERING, INC.

NOMOGRAPH – INLET CONTROL BOX CULVERT

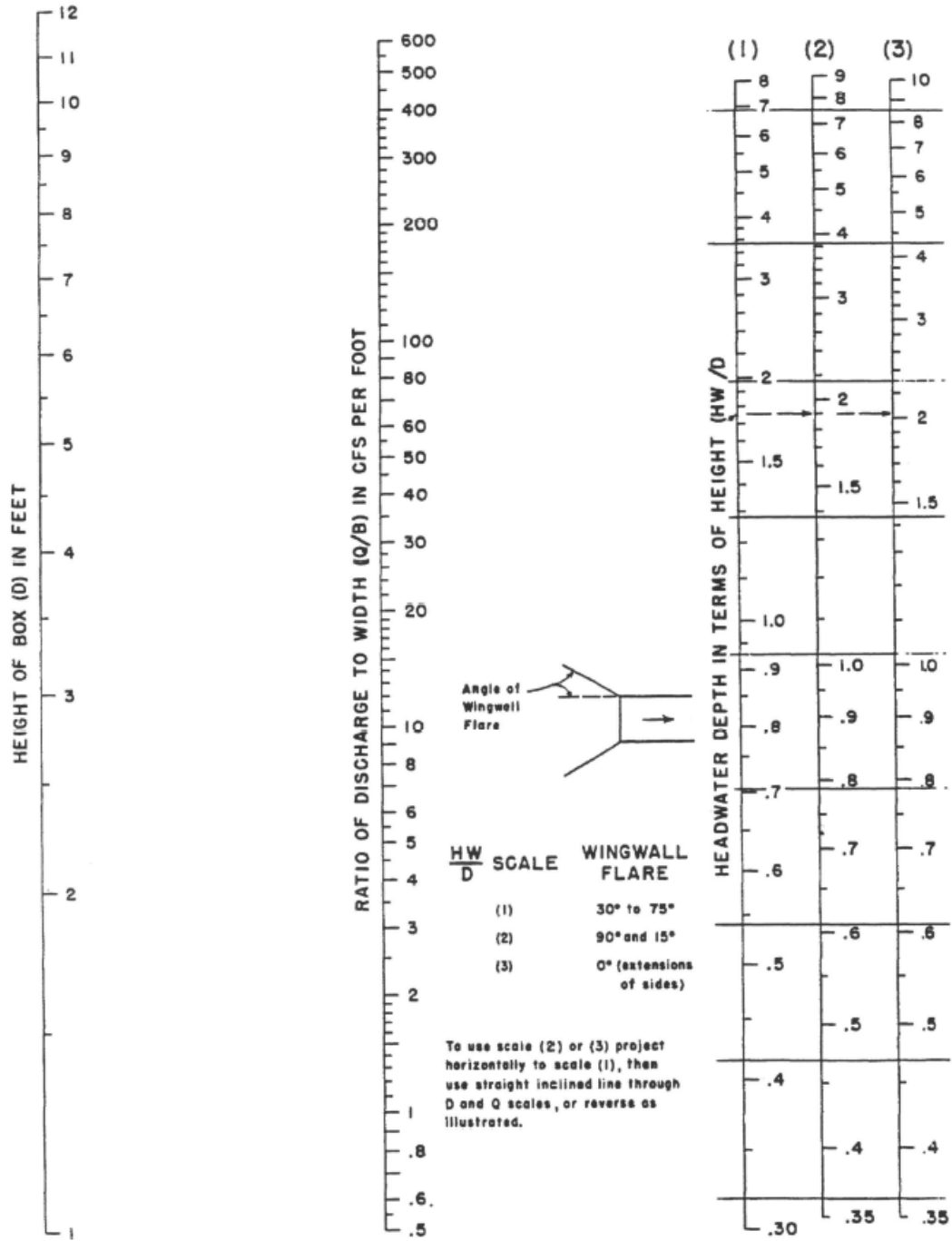

VERSION: April 30, 2009

REFERENCE:

FIGURE 1103

WTC ENGINEERING, INC.

NOMOGRAPH – INLET CONTROL RCP

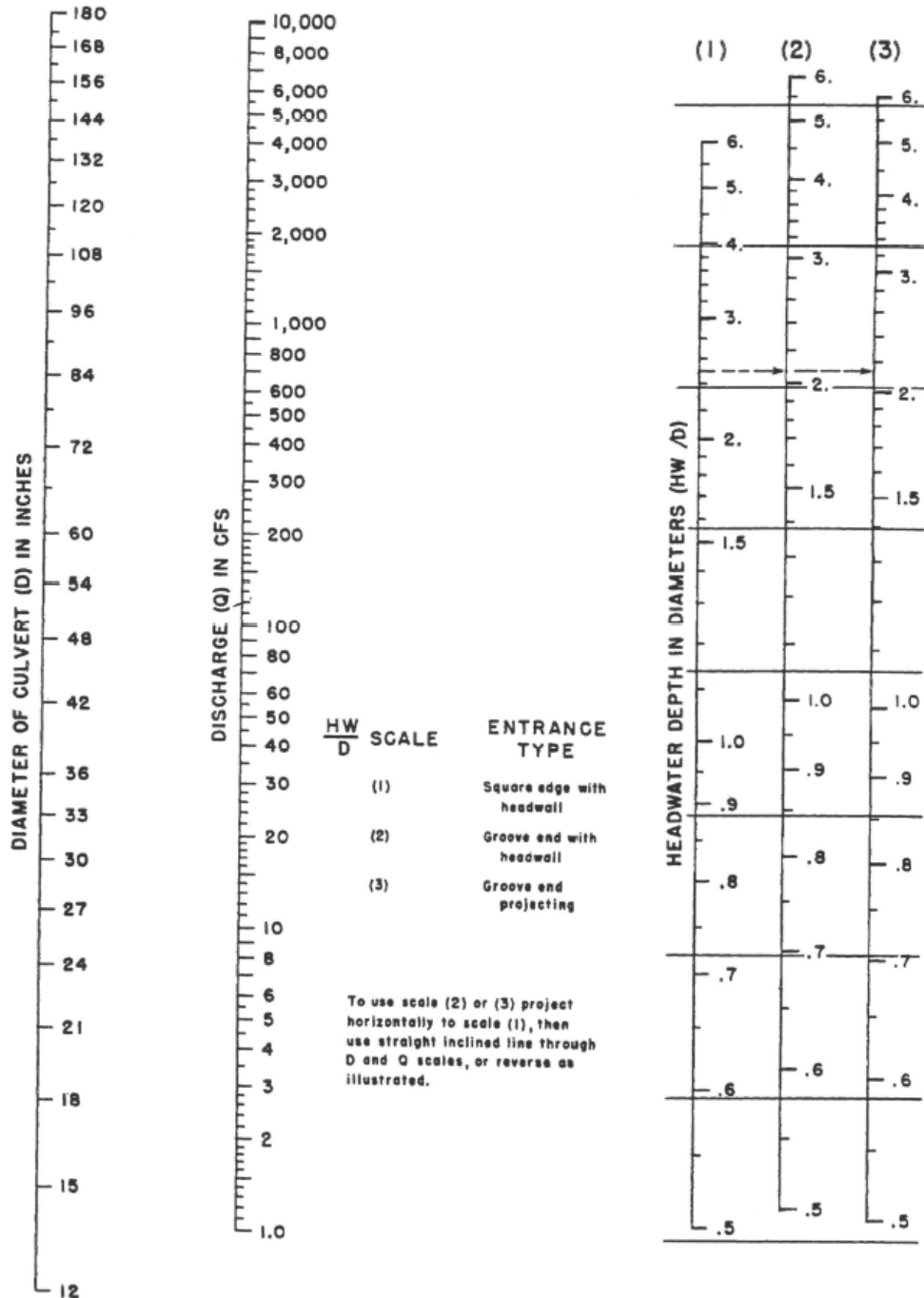

VERSION: April 30, 2009

REFERENCE:

FIGURE 1104

WTC ENGINEERING, INC.

NOMOGRAPH – INLET CONTROL ELLIPTICAL PIPE

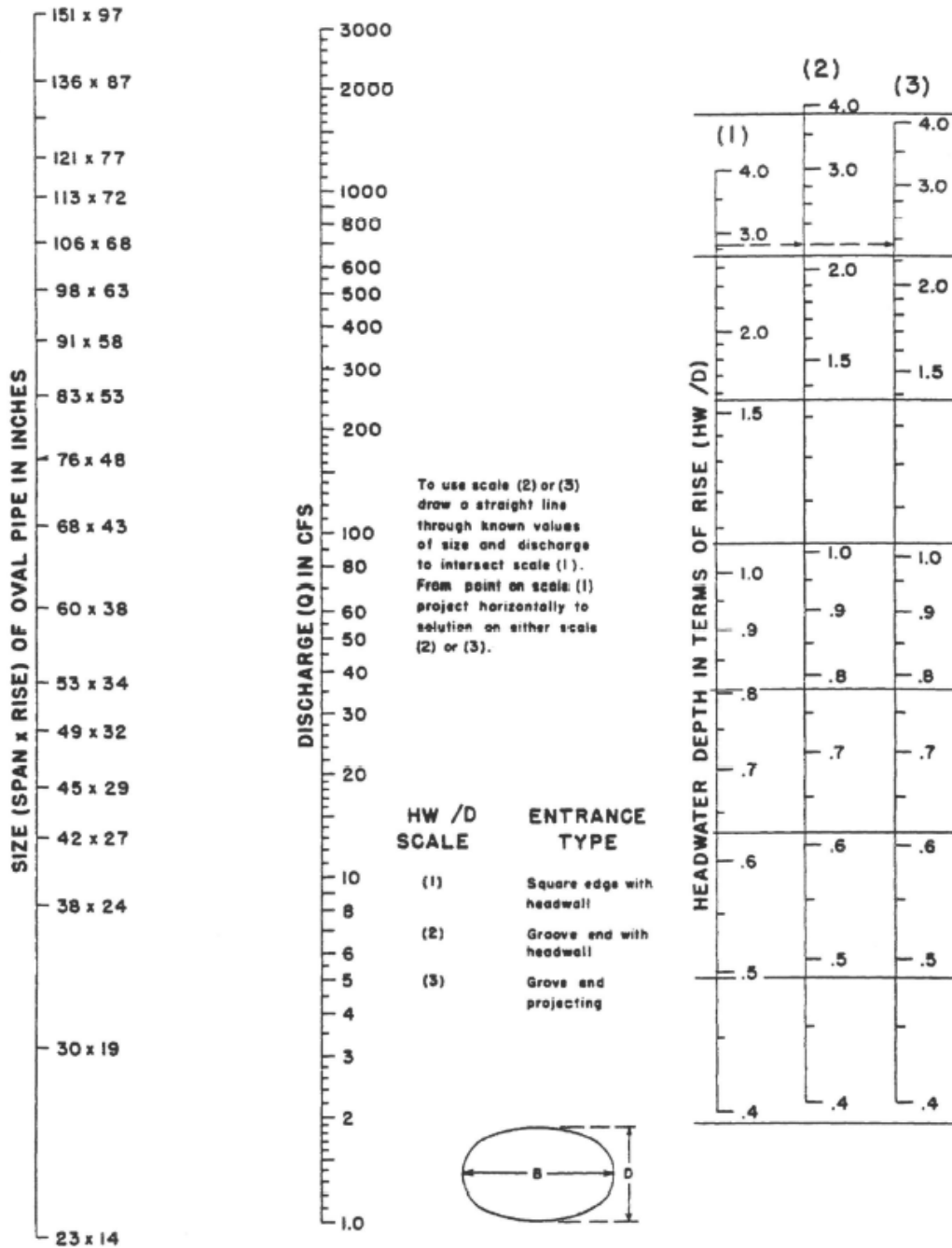

VERSION: April 30, 2009

REFERENCE:

FIGURE
1105

WTC ENGINEERING, INC.

OUTLET CONTROL CULVERT HYDRAULICS

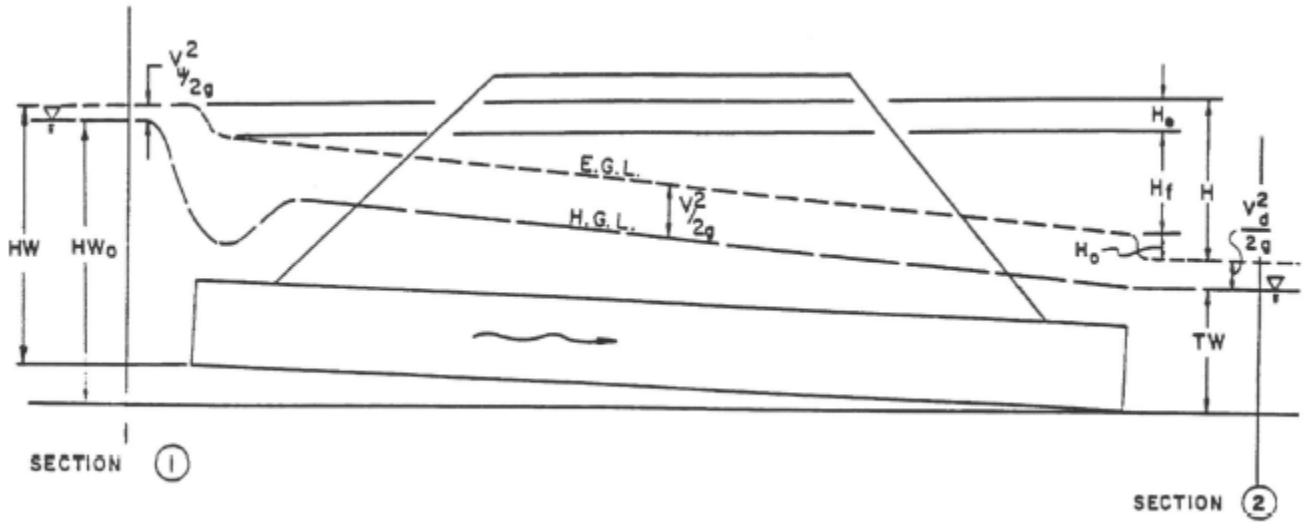

VERSION: April 30, 2009

REFERENCE:

FIGURE
1106

WTC ENGINEERING, INC.

CRITICAL DEPTH – RECTANGULAR SECTION



CHART 14

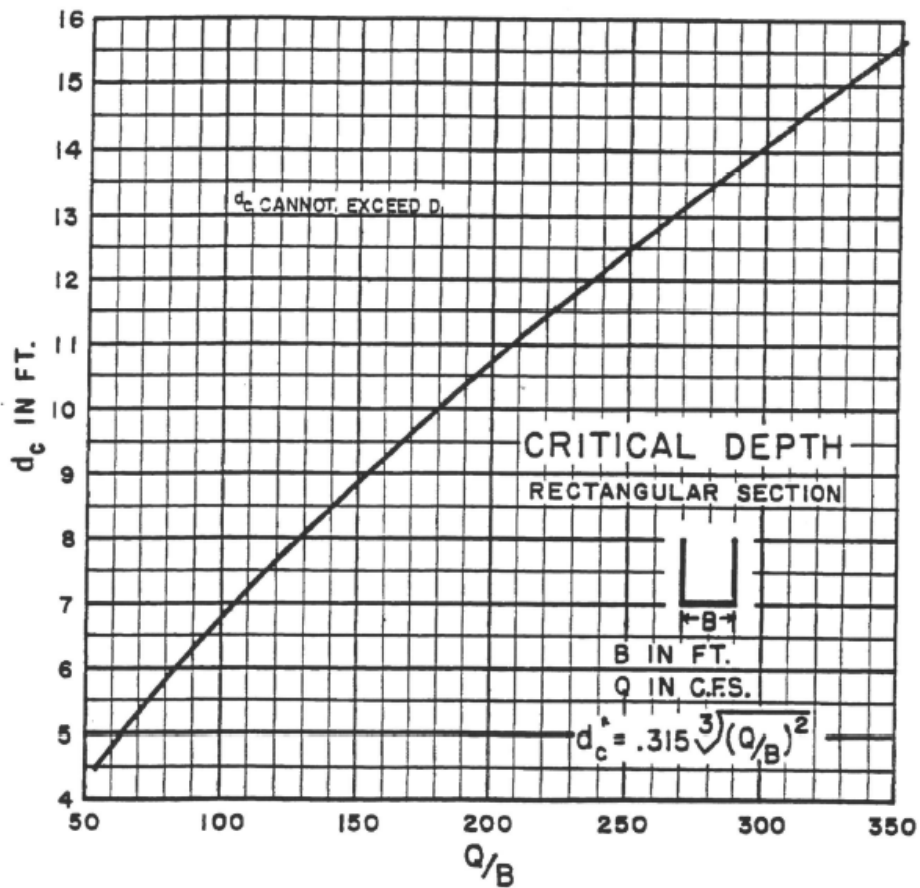
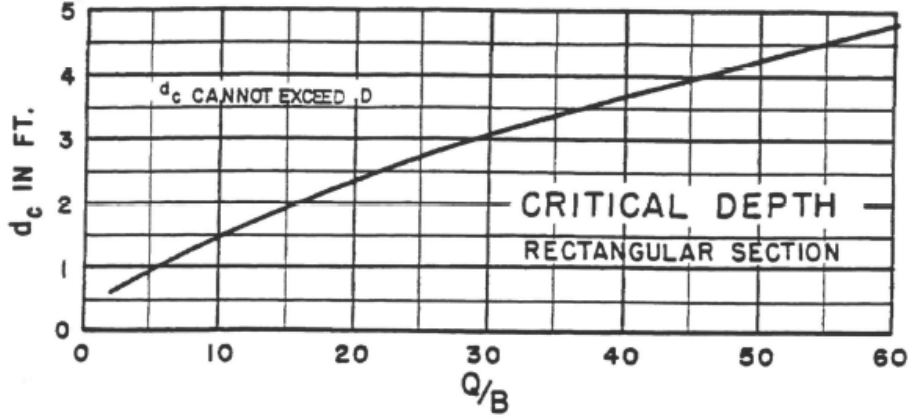

VERSION: April 30, 2009

REFERENCE:
Bureau of Public Roads, January 1963

FIGURE
1107

WTC ENGINEERING, INC.

CRITICAL DEPTH - CIRCULAR SECTION



CHART 4

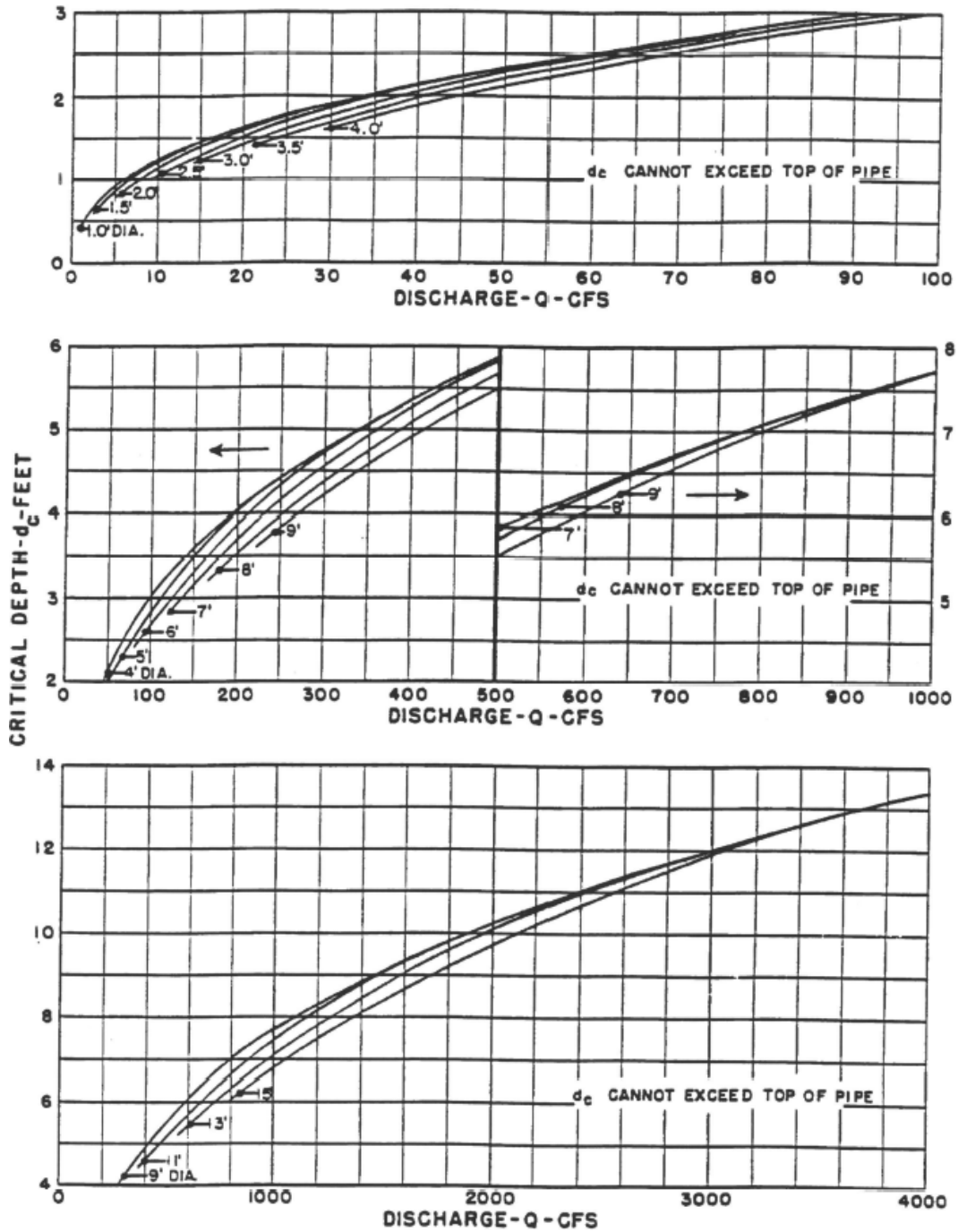

VERSION: April 30, 2009

REFERENCE:

Bureau of Public Roads, January 1964

FIGURE 1108

WTC ENGINEERING, INC.

**CRITICAL DEPTH – OVAL CONCRETE PIPE
LONG AXIS HORIZONTAL**



CHART 31

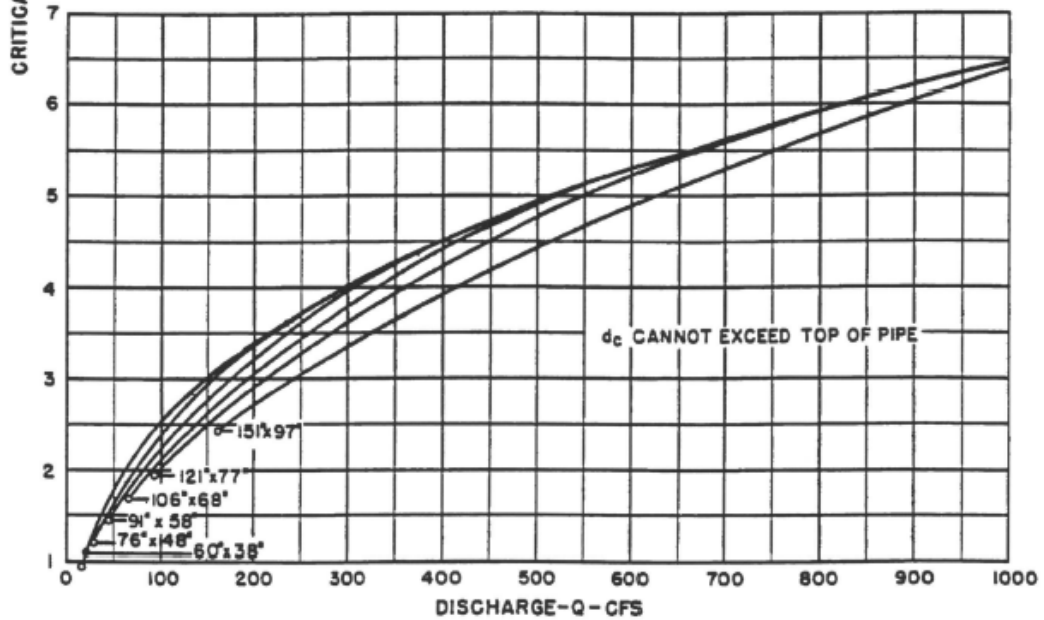
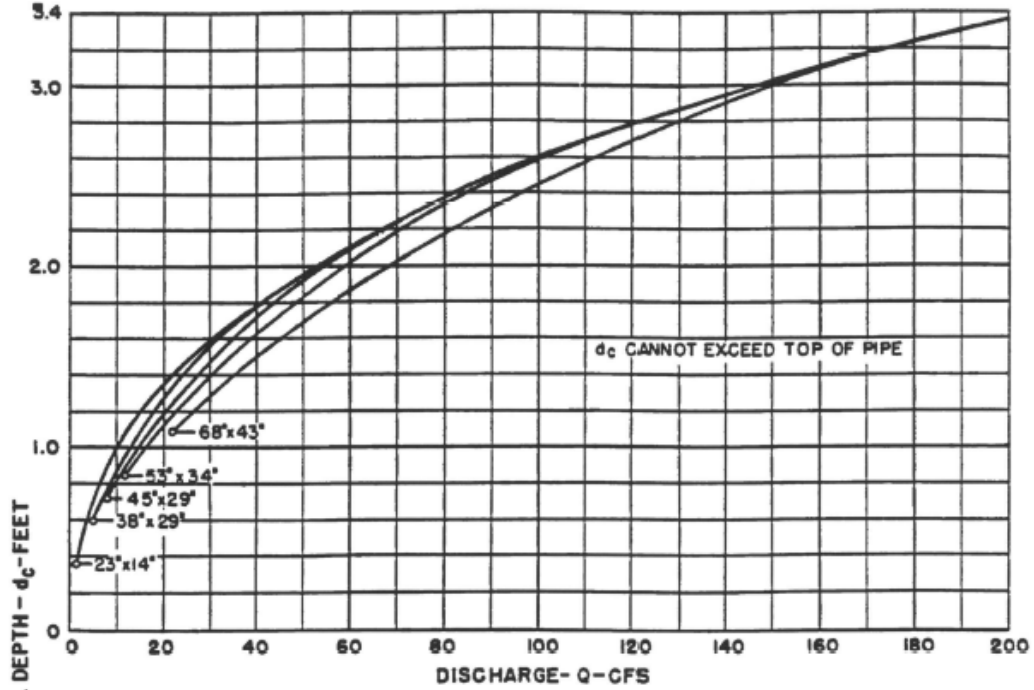

VERSION: April 30, 2009

REFERENCE:
Bureau of Public Roads, January 1964

FIGURE
1109

WTC ENGINEERING, INC.

**NOMOGRAPH – OUTLET CONTROL BOX CULVERT
($n=0.012$)**

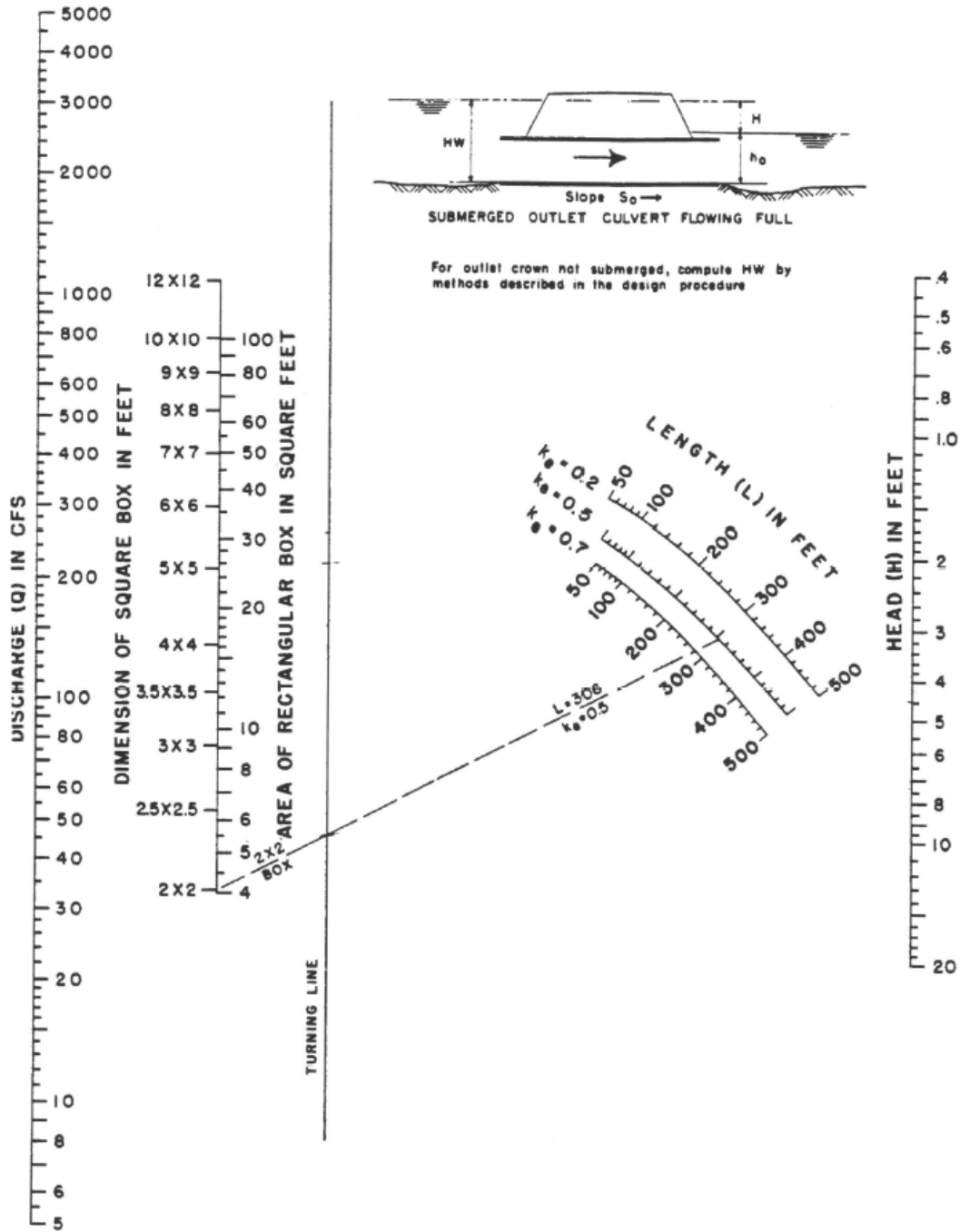

VERSION: April 30, 2009

REFERENCE:

FIGURE
1110

WTC ENGINEERING, INC.

**NOMOGRAPH – OUTLET CONTROL RCP
(n=0.012)**

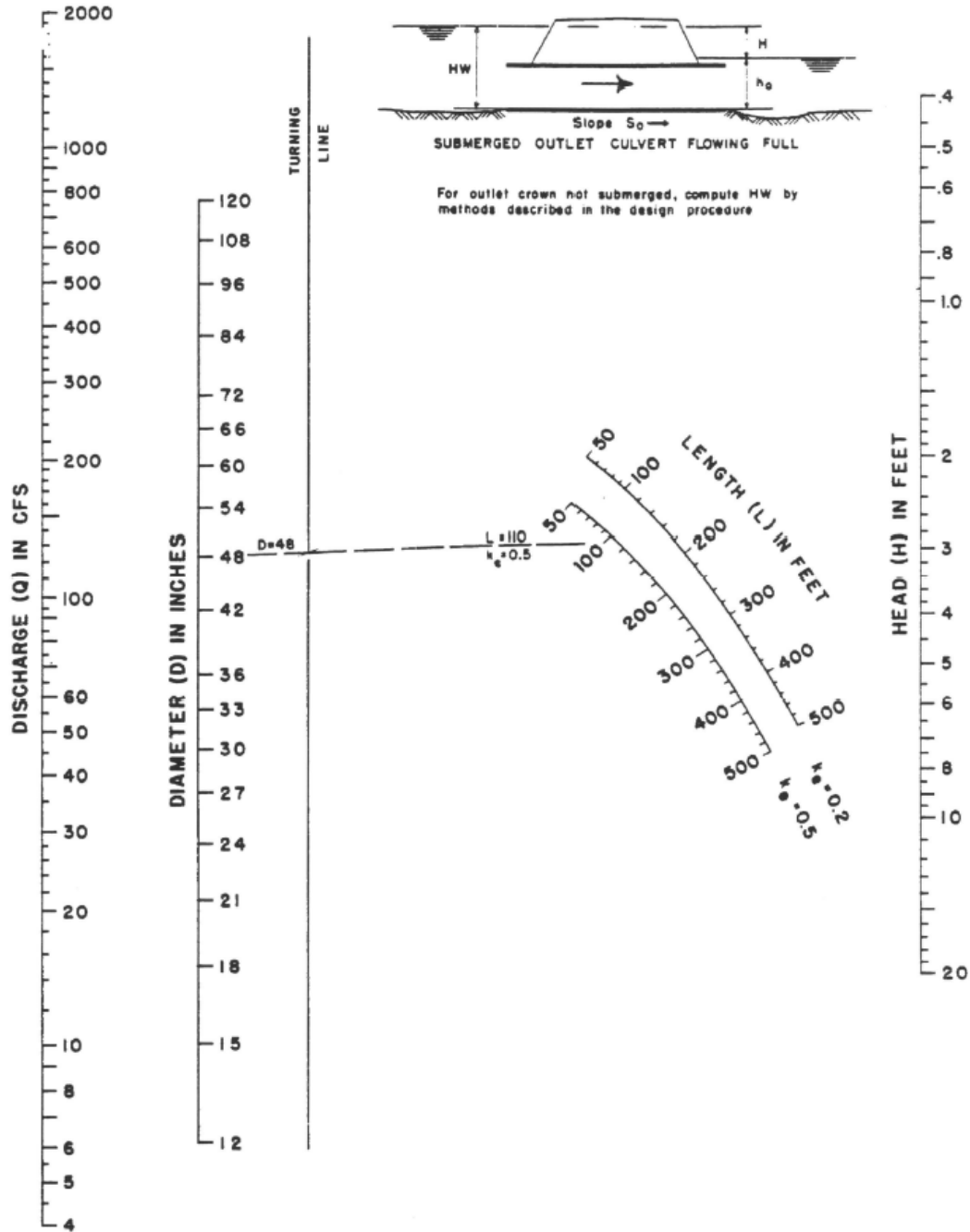

VERSION: April 30, 2009

REFERENCE:

FIGURE
1111

WTC ENGINEERING, INC.

**NOMOGRAPH – OUTLET CONTROL ELLIPTICAL PIPE
(n=0.012)**

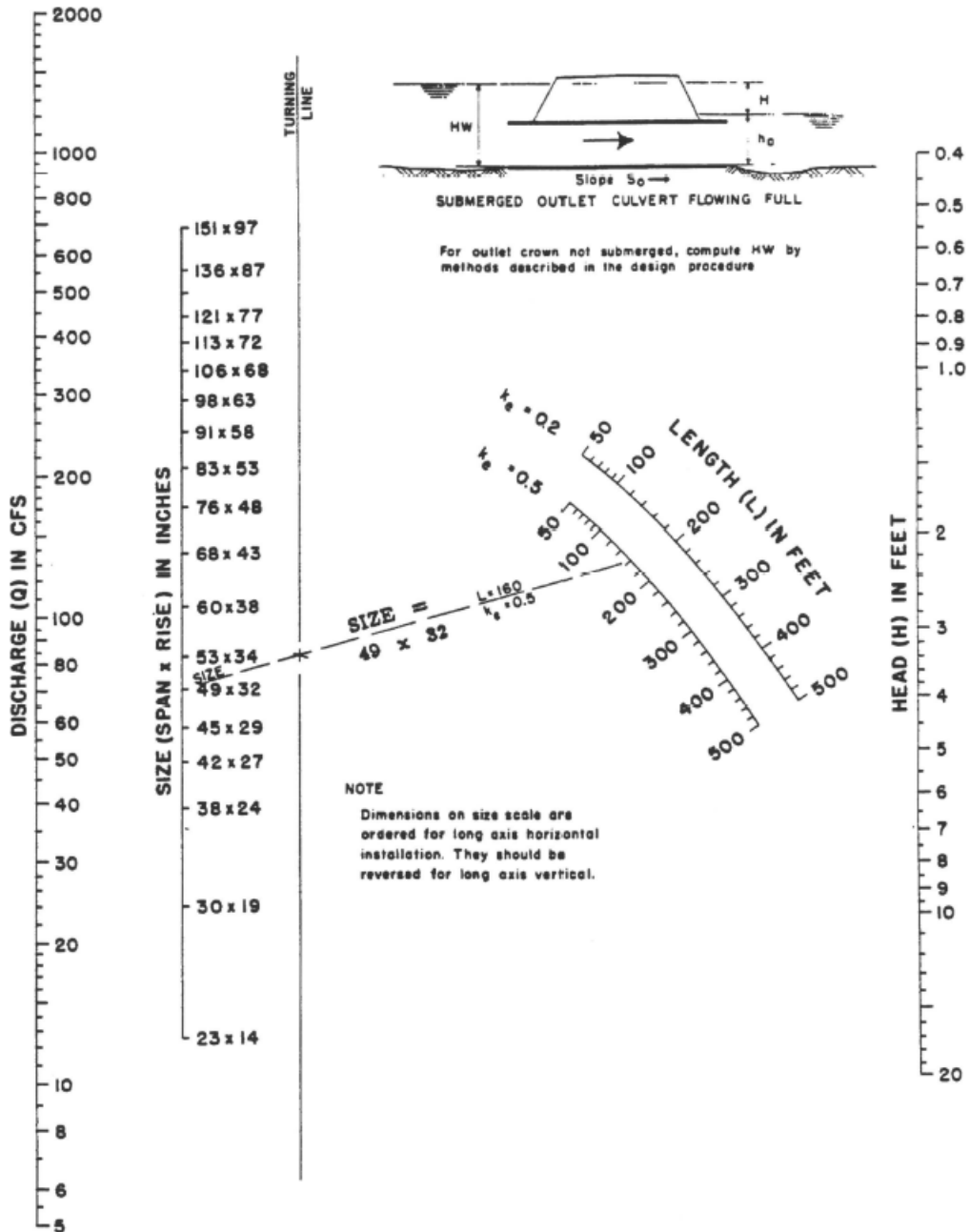

VERSION: April 30, 2009

REFERENCE:

FIGURE
1112

WTC ENGINEERING, INC.

EXAMPLE: NOMOGRAPH – INLET CONTROL RCP

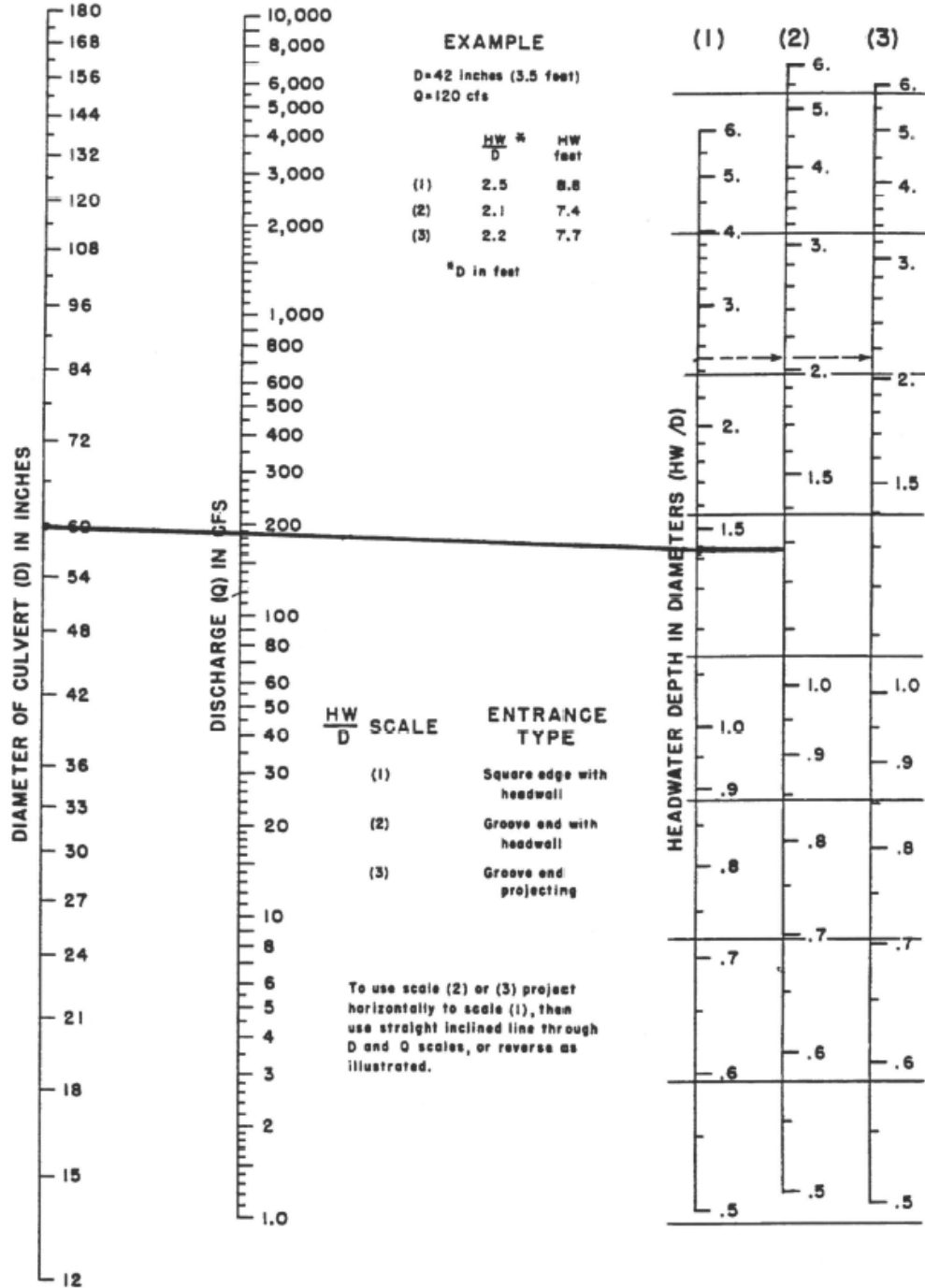

EXAMPLE: NOMOGRAPH - CRITICAL DEPTH - CIRCULAR PIPE



CHART 4

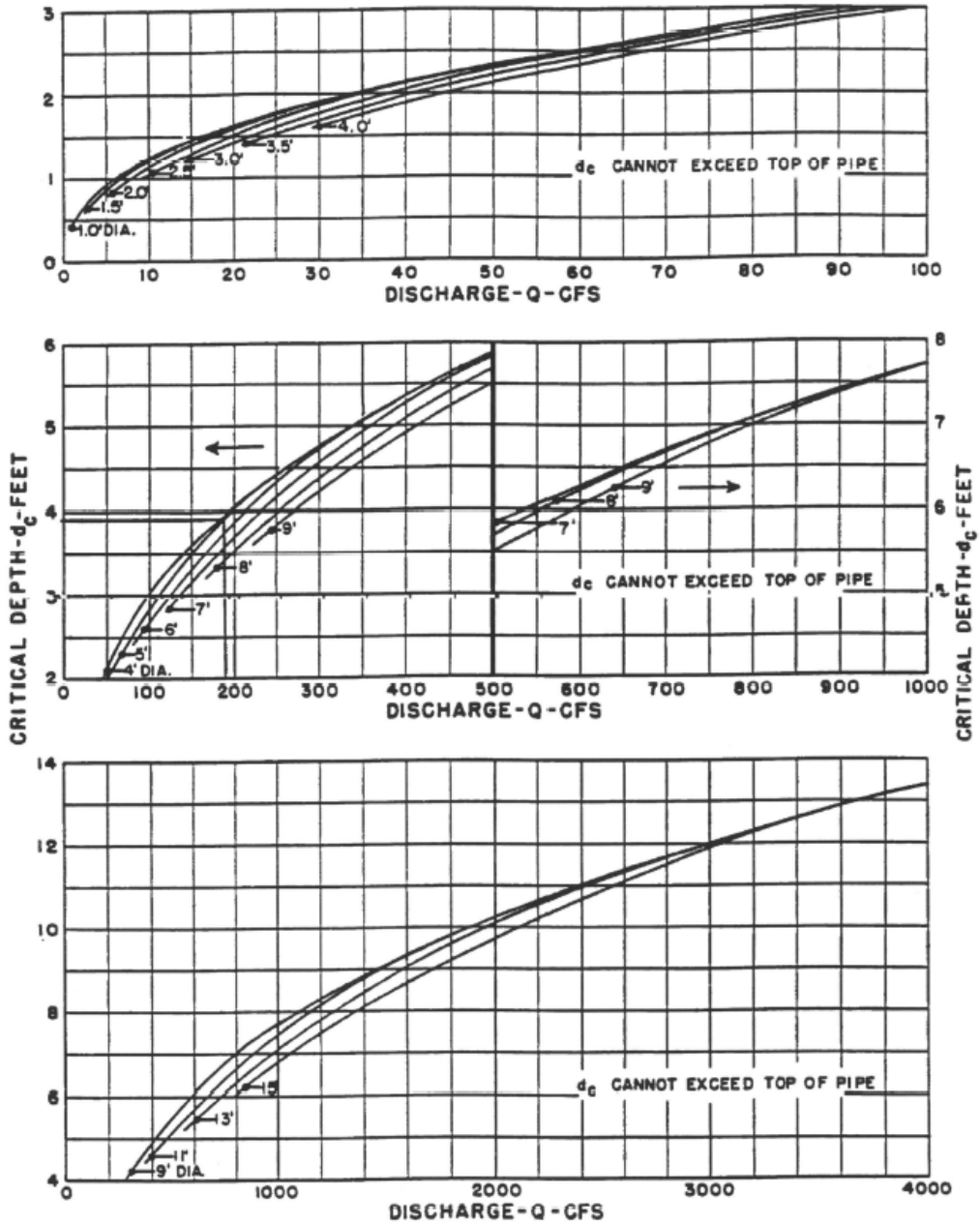

VERSION: April 30, 2009

REFERENCE:

Bureau of Public Roads, January 1964

FIGURE

1114

WTC ENGINEERING, INC.

**EXAMPLE: NOMOGRAPH – OUTLET CONTROL RCP
($n=0.012$)**

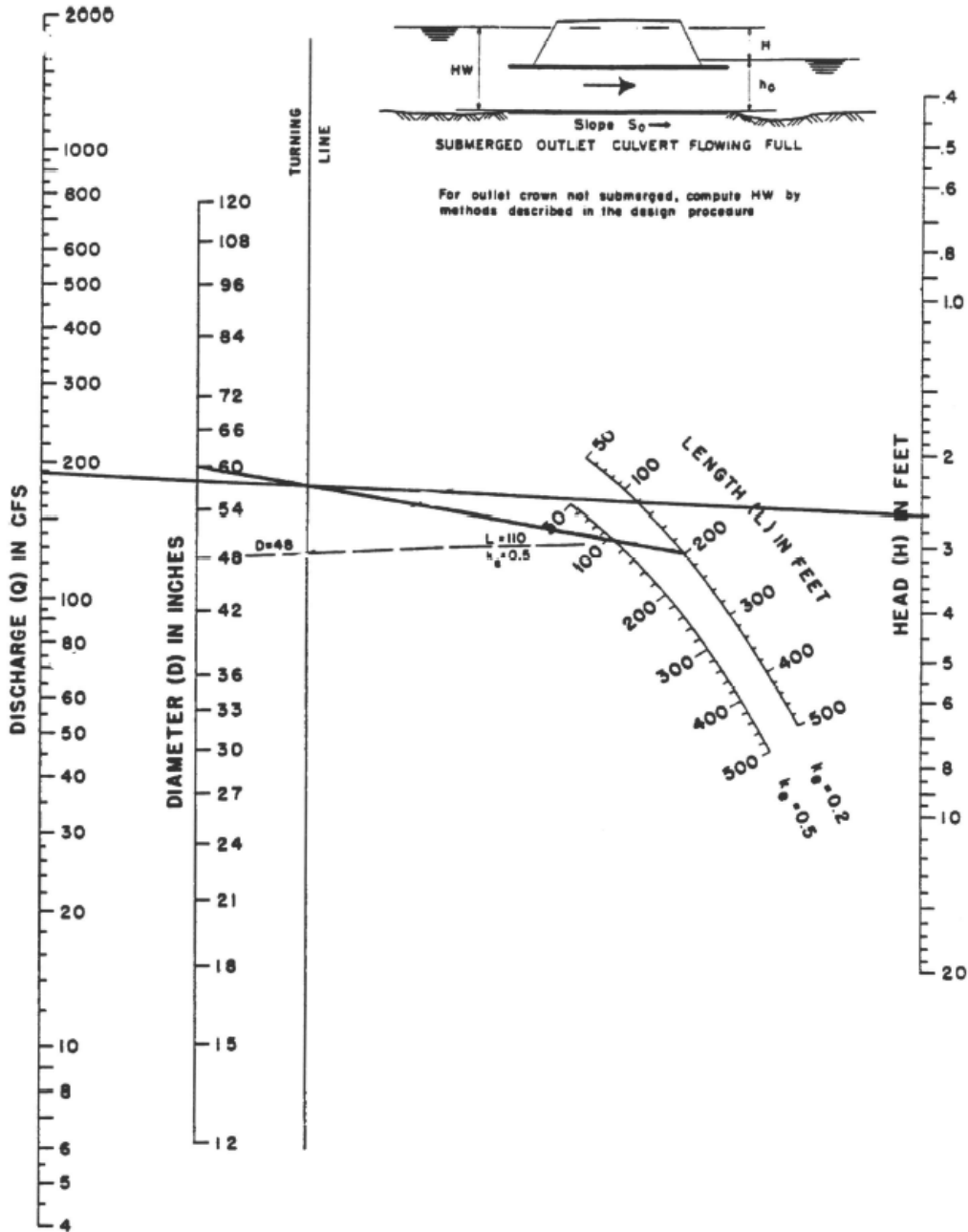

VERSION: April 30, 2009

REFERENCE:

FIGURE
1115

WTC ENGINEERING, INC.

SECTION 1200 - ADDITIONAL HYDRAULIC STRUCTURES

TABLE OF CONTENTS

	<u>Page</u>
1201 INTRODUCTION	1201
1202 CHANNEL DROPS AND ENERGY DISSIPATION STRUCTURES.....	1201
1202.1 CHANNEL DROP STRUCTURES.....	1201
1202.2 ENERGY DISSIPATION STRUCTURES	1207

LIST OF TABLES

1201	CHANNEL DROP AND ENERGY DISSIPATION STRUCTURES
1202	SLOPING GROUTED BOULDER DROP DESIGN PARAMETERS
1203	SLOPING GROUTED BOULDER DROP ROCK AND GROUT THICKNESS

LIST OF FIGURES

1201	DROP STRUCTURES
1202	SLOPING GROUTED BOULDER DROP
1203	SLOPING GROUTED BOULDER DROP SCHEMATIC
1204	TYPICAL GROUTED BOULDER PLACEMENT
1205	WEEP DRAIN SYSTEM DETAILS
1206	VERTICAL RIPRAP DROP
1207	CURVES FOR SCOUR DEPTH AT VERTICAL DROP
1208	STRAIGHT DROP SPILLWAY
1209	BAFFLED APRON STILLING BASIN (USBR TYPE IX)
1210	DESIGN DATA – USBR TYPE STILLING BASINS
1211	SHORT STILLING BASIN (USBR TYPE III)
1212	LOW FROUDE NUMBER STILLING BASIN (USBR TYPE IV)
1213	IMPACT STILLING BASIN (USBR TYPE VI)
1214	TYPICAL TRAJECTORY TRANSITION

SECTION 1200

ADDITIONAL HYDRAULIC STRUCTURES

1201 INTRODUCTION

Presented in this section are design guidelines and standards for hydraulic structures which are appurtenant to both storm sewer outlet and open channel design. These guidelines and standards are generalized since each structure is unique, with the possible exception of channel drops. The user is encouraged to coordinate with the Jurisdictional Entity when planning and designing these types of hydraulic structures.

1202 CHANNEL DROPS AND ENERGY DISSIPATION STRUCTURES

The design of open channels often requires the use of channel drop and/or energy dissipation structures to dissipate excess energy created by gravity acting on the storm water flow. The most common use of these structures is to control the longitudinal slope of channels to keep design velocities within acceptable limits (Section 800). These structures are also used to dissipate excess energy at storm sewer outlets.

For the purposes of this Manual, channel drop and energy dissipation structures are classified into two groups. Channel Drops are classified as structures which shall only be used when the inflow channel flow is subcritical (Froude number, $F_r < 0.8$). Energy Dissipators (and Stilling Basins) are classified as structures which may be used for either subcritical ($F_r < 0.8$) or supercritical ($F_r > 1.13$) inflow conditions.

Presented in Table 1201 is a listing of the structures discussed in this section along with the hydraulic limitations under which these structures are allowed to be used within the Washoe County area. The designer must obtain prior approval from the Jurisdictional Entity to use any of the listed structures outside of the stated limits. Also, if the designer desires to use a structure not discussed in this section, pertinent detailed information on the structure must be submitted to the Jurisdictional Entity for review and approval prior to designing the facility.

Criteria and charts to aid in the design of these types of structures have been developed based on numerous hydraulic studies and are provided in the following sections.

The reader should refer to the standard channel drop and energy dissipation design references to become familiar with the detailed information available on each type of structure prior to design. Suggested references include Perterka, 1978; USBR, 1987; and USACE, 1970.

1202.1 CHANNEL DROP STRUCTURES

Presented in Table 1201 are the types of channel drop structures allowed in the Washoe County area. By definition, channel drop structures are used only when the upstream channel flow is subcritical. Figure 1201 presents the generalized profiles and nomenclature for these types of drop structures. This nomenclature is used throughout this section for discussion of specific standards for each part of the structure.

1202.1.1 SLOPING GROUTED BOULDER DROP STRUCTURES

This type of structure has gained popularity due to design aesthetics and successful applications. The quality of rock used and proper grouting procedure are very important to the structural integrity. There is no maximum height requirement for this type of structure.

The sloping grouted boulder drop is designed to operate as a hydraulic jump dissipator, although some energy loss is incurred due to the roughness of the grouted rock slope. Structure integrity and containment of the erosive turbulence within the basin area, are the main design objectives.

Grouted boulder drops must be constructed of uniform size boulders grouted in place through the approach, sloping face, basin, and exit areas of the drop. Figures 1202, 1203, and 1204 illustrate the general configuration of the sloping grouted boulder drop structure. Table 1202 supplies the design criteria for the drop structure based on the flow, drop height, and soil erosiveness.

1202.1.1.1 Design

- a) Rock and Grout: The grout thickness, D_g , and rock thickness, D_r , are determined based on a minimum surplus net downward force of 30 pounds. The grouted boulder section is only one layer thick. The rock size with its corresponding depth of grout is provided in Table 1203. A thicker layer of grout will reduce the appearance and the energy dissipation characteristics of the drop structure. Refer to Denver Urban Drainage and Flood Control District, Drainage Criteria Manual (current version).

The rock used for the grouted boulder drop structure is different from the standard riprap gradation in that the smaller rock has been removed to allow greater penetration by the grout. The boulders are placed directly on the subgrade with no bedding. The boulders should be placed as closely together as possible without disturbing the subgrade. Boulders should also be placed with the flattest surface horizontal and on top. Before the grout is placed, the rock should be sprayed with clean water to clean the rock and allow better adherence by the grout to the rock.

The voids between the boulders are then filled with grout meeting the specifications outlined in the Standard Specifications. The grout should be vibrated with a pencil vibrator to ensure complete penetration and filling of the voids. A small hand broom or gloved hand is used to smooth the grout and remove any excess grout from the rock. The finished surface should be sealed with a curing compound.

- b) Approach Apron: The upstream channel will have a trapezoidal section designed according to Section 800. The length of the approach apron will be as shown in Table 1202. The width of the approach apron and the side slopes will be identical to the upstream channel. The height of grouted boulder channel sides will be equal to the depth of water in the upstream channel plus the required freeboard as described in Section 800. The approach apron is provided to protect against the increasing velocities and turbulence which result as the water approaches the sloping portion of the drop structure.

A concrete or grout cutoff wall shall be placed at the top of the slope and on the upstream side of the approach apron to reduce or eliminate seepage and piping along with the failures which can result from these problems. The depth of the cutoff wall should be at least the full depth of the riprap layer and at least 1-foot thick. Depending on the soil type and hydraulic forces acting on the drop structure, the cutoff wall may need to be deeper to lengthen the seepage flow path.

- c) Drop: The slope of the drop structure should not be steeper than 4:1. Slopes flatter than 4:1 usually increase expense, but some improvement in appearance may be gained. The side slopes and bottom width of the drop should be the same as the upstream channel. The grouted boulders should extend up the side slopes a height of the tailwater depth plus the required freeboard as projected from the downstream channel (as described in Section 800) or the critical depth plus 1 foot, whichever is greater.
- d) Basin: The main stilling basin is depressed 1 to 2 feet in order to stabilize the hydraulic jump. The basin shall be constructed to the dimensions provided in Table 1202 and shown in Figures 1202 and 1203. The grouted boulder sides should extend up the side slopes a height of the tailwater depth plus the required freeboard as projected from the downstream channel (as described in Section 800).
- e) Exit Apron: The exit apron is necessary to minimize any erosion that may occur due to secondary currents. The bottom width and side slopes of the exit apron should be the same as the downstream channel. The grouted boulder channel sides should extend to a height equal to the tailwater depth plus the required freeboard (as described in Section 800). The length of the exit apron should be according to Table 1202.
- f) Low-flow channel: A low-flow channel will extend through the drop structure as shown in Figure 1202 connecting the upstream low-flow channel to the downstream low-flow channel. Due to the greater depth of flow in the low-flow channel as compared to the main channel, the low-flow channel will have higher velocities and greater energy, and the jump will tend to wash downstream of the basin. Large boulders should be placed in the low-flow channel in the bottom of the basin to help dissipate the higher flow energy.
- g) Drainage: Subgrade erosion caused by seepage and structure failures caused by high seepage pressures or inadequate mass is of critical concern. These factors are very important in the design and must be analyzed.

The most sophisticated means of seepage analysis involves computerized groundwater flow modeling. Advanced geotechnical field and laboratory testing techniques may be used to confirm the accepted permeability values where complicated seepage problems are anticipated. Several flow net analysis programs are currently available that are suitable for this purpose. These methods are discussed in Cedegren, 1967, Taylor, 1967, and USBR, 1987.

A minimal approach is Lane's Weighted Creep Method (Lane, 1935). It can be used to determine dimensions or cutoff improvements which would provide an adequate seepage length. It should only be used as a guideline, and when marginal conditions or complicated geological conditions exist, a more precise analysis should be used.

Weep drains are needed for seepage and uplift control. Weep drains for grouted sloping boulder drop structures are shown in Figure 1205. This type of system is appropriate for smaller drops and other locations where space is limited. A continuous manifold is preferred over a "point" system for weep drainage of a drop structure as it provides more complete interception of subsurface drainage. Contact the Jurisdictional Entity to discuss specific design criteria and modifications that may be required.

Weep systems require special attention during construction. The pipes can be crushed by the boulders and alignment of the pipes between the boulders is difficult. Flexible outlet pipes should be used to allow alignment of the pipes around the boulders.

1202.1.2 VERTICAL RIPRAP DROP STRUCTURES

1202.1.2.1 Introduction

Energy dissipation is achieved in this type of drop by flow plunging into a pool where the energy is expended by turbulence. The pool is created by specific placement and construction of a basin or by a "planned" rearrangement of rock by the flow.

The structural design for the vertical crest wall is complicated by the lack of downstream support, seepage, soil saturation and hydraulic loading on the upstream side. In sandy or erosive soils, it is quite common to use sheet pile for crest wall construction, while caissons may prove acceptable for certain other applications. Commonly a retaining wall is used after evaluating seepage control.

Figures 1206 and 1207 provide the design standards and details for vertical riprap drop structures. The design curves for the vertical channel drop structures are based upon the height of the drop and the normal depth and velocity of the approach and exit channels. The channel must be prismatic throughout, from the upstream channel through the drop to the downstream channel.

The maximum (steepest) allowable side slope for the riprap stilling basin is 4:1. Flatter side slopes are allowable and encouraged when available right-of-way permits. The riprap should extend up the side slopes to a depth equal to one foot above the normal depth projected upstream from the downstream channel.

The crest wall is a structural retaining wall which is buried at least 3 feet below the level of the rock bedding layer in the drop basin. A low-flow channel is carried through the wall. The top of the crest wall should not extend above the upstream invert elevation. The low-flow slab should consider wall movement and be tied to the structure.

Crest wall and footer dimensions are determined by conventional structural methods. Underdrain requirements are determined from seepage analysis.

The following design methodology is adapted from Stevens, 1981. The design is essentially that which was developed and model tested by Smith, 1965. The structure is an adaptation of the reinforced concrete vertical drop structure adapted to smaller heads and drop heights.

1202.1.2.2 Design

The crest wall height extends to the energy gradeline above the drop crest. The crest wall height, H_m , is given by the following equation.

$$H_m = EGL_m - Elev_c \tag{1201}$$

where

EGL_m = Energy gradeline elevation at main crest of drop
 $Elev_c$ = Invert elevation of main channel at crest of drop

Since the flow is at critical depth at the crest of the drop, the energy gradeline elevation can be calculated with the following equations.

$$V_{cm} = (g * y_{cm})^{0.5} \tag{1202}$$

where

- V_{cm} = Critical velocity of main channel
- y_{cm} = Critical depth of main channel
- g = Acceleration of gravity (32.2 ft/sec²)

$$EGL_m = y_m + \frac{V_{cm}^2}{2g} + Elev_c \quad (1203)$$

The wingwalls (Figure 1206) are required to direct the flow coming along the sides of the approach channel into the plunge pool. The width of the crest is the same as the bed of the approach section. The height of the wingwalls above the main crest is the same as the crest wall height calculated above.

The wingwalls must extend below the depth of excavation for the plunge pool and must provide an adequately long seepage path to prevent piping. A separate analysis at the low-flow channel is required as follows:

$$H_t = EGL_t - Elev_t \quad (1204)$$

where

- EGL_t = Energy gradeline elevation of low-flow channel at main crest of drop
- $Elev_t$ = Invert elevation of low-flow channel at crest of drop

and

$$EGL_t = y_{ct} + \frac{V_{ct}^2}{2g} + Elev_t \quad (1205)$$

where

- y_{ct} = Critical depth of low-flow channel
- V_{ct} = Velocity of low-flow channel
- g = Acceleration of gravity (32.2 ft/sec²)

The plunge pool is a deep bed of rock riprap initially placed level across the floor of plunge pool and extending downstream.

$$L_b = 4H_m + 0.25D \quad (1206)$$

where

- L_b = Length of basin
- D = Depth of drop

The first flow over the weir initially falls on the rock bed and begins to form a scour hole. The rocks removed from the scour hole are deposited in the area between the scour hole and the beginning of the downstream channel. With substantial flow or a repetition of flow, a mound of stones forms downstream from the scour hole. The mound is an integral part of the energy dissipating structure and must be maintained. This is achieved by initially placing the

top of the stone bed below the downstream channel bed by an amount equal to two-thirds of the scour depth, d_s , at the design discharge. The scour hole must be allowed to develop by natural means and generally should not be preformed.

The desired drop across the structure is the difference in the bed elevations of the approach channel at the weir and the downstream channel at the end of the structure. Let this difference be H_d . It follows from Figure 1206 that:

$$H_d = D - 0.67d_s \quad (1207)$$

The designer must find the combination of rock size and jet plunge height, D , that gives a depth of scour which balances Equation 1207. The relation between rock size, d_{50} , jet plunge height, D , head on the weir, H , and depth of scour, d_s , is given in Figure 1207. As these values will be different in the main drop and the low-flow, the design d_{50} and/or d_s will vary. This assumes that this is an appropriate extrapolation of the modeling work, which would appear reasonable if the low-flow and adjacent areas are treated conservatively.

To obtain an adequate cutoff, the depth of the vertical wall that forms the weir crest must extend below the bottom of the excavation for the riprap. Therefore, it is usually uneconomical to design a scour depth d_s any greater than $0.3D$. To meet this limitation in the field, it is necessary to increase the rock size d_{50} , decrease the jet plunge height D (by using more drops), decrease H (by using a wider structure), or use another type of drop structure.

A contingency factor of 25% to 50% should be applied to the rock depth in areas of erosive soils since experience has shown that basin rock rearrangement can cause collapse into the basin center.

The side slopes in the basin must be riprapped also as there are strong back currents in the basin. A sand and gravel or cloth filter is required under this riprap. The side slopes in the basin should be the same slope as for the downstream channel (but no steeper than 4 horizontal to 1 vertical).

The following provides a summary of the design parameters used in Figure 1206.

b_t	=	Low-flow channel width
Y_n	=	Depths of flow upstream of drop
H_{cw}	=	Depth of upstream cutoff wall
Y_2	=	Tailwater depth
B	=	$.67 d_s$ = basin depth
D_R	=	$1.5 d_s$ = riprap depth
L_r	=	Length of endsill
H_d	=	$D - .67 d_s$
H_{tw}	=	Depth of downstream cutoff wall
L_A	=	Length of riprap upstream scour drop
H_m	=	Crest of wall height above main channel invert
D	=	Depth of drop
d_{50}	=	Median diameter of riprap
L_b	=	Length of basin = $4H_m + 0.25D$
d_s	= y	Depth of scour $\leq 0.3D$ (Determine from Figure 1207)

1202.1.3 STRAIGHT DROP SPILLWAYS

Presented in Figure 1208 are the design details for a straight drop spillway. The spillway produces a controlled overflow jet which is dissipated through impact on the structure floor and baffle blocks. The jet energy is also dissipated in the plunge pool created when impact blocks are used or through a hydraulic jump using the typical baffle block arrangements from the USBR stilling basin designs.

The basin design is based on the drop distance, Y, and the unit discharge, q, as related through the drop number, D, computed as follows:

$$D = \frac{q^2}{gY^3} \tag{1208}$$

where D = Drop Number (dimensionless)
 q = Unit discharge (cubic feet per second per foot of width)
 Y = Drop distance (feet)
 g = Acceleration of gravity (32.2 ft/sec²)

The remaining design parameters can be obtained from Figure 1208.

The impact block basin is applicable for low heads with a wide range of tailwater depths. The hydraulic jump basin may be used as long as the design parameters for the selected basin type are met. The designer is referred to USBR, 1987, for detailed design information, guidelines, and examples.

1202.1.4 BAFFLED APRONS (USBR TYPE IX)

Presented in Figure 1209 is the Baffled Apron Stilling Basin. This structure requires no initial tailwater to be effective, although when the tailwater forms a pool into which the flow discharges, the channel bed scour is not as deep and is less extensive. The chutes are constructed on an excavated slope, 2:1 or flatter, extending to below the channel bottom. Backfill is placed over one or more rows of baffles to restore the original streambed elevation. When scour or downstream channel degradation occurs, successive rows of baffle piers are exposed to prevent excessive acceleration of the flow entering the channel. If degradation does not occur, the scour creates a stilling pool at the downstream end of the chute, stabilizing the scour pattern.

Generalized design information is presented in Figure 1210. The designer is referred to Peterka, 1978 for detailed design information, guidelines, and examples.

1202.2 ENERGY DISSIPATION STRUCTURES

Presented in Table 1201 are some types of energy dissipation structures allowed in the Washoe County area. By definition, energy dissipation structures may be used for both subcritical and supercritical upstream channel (or pipe) flow conditions. For subcritical flow conditions, these structures are designed similar to the channel drop structures discussed in the previous section. For supercritical flow conditions, the upstream channel is tied directly into the stilling basin floor (hydraulic rise) or the upstream channel is transitioned into the structure through the use of a trajectory transition section. The hydraulic design of trajectory transition sections is discussed in Section 1202.2.6.

1202.2.1 TYPES OF ENERGY DISSIPATION STRUCTURES

Many types of stilling basins and energy-dissipating devices are available in conjunction with spillways, outlet works, and canal structures. These structures utilize blocks, sills, or other roughness elements to impose exaggerated resistance to the flow and dissipate excessive energy. The type of stilling basin selected is based upon hydraulic requirements, available space and cost. The hydraulic jump which occurs in a stilling basin has distinctive characteristics depending on the energy of the flow which must be dissipated in relation to the depth of the flow. A comprehensive series of tests have been performed by the Bureau of Reclamation for determining the most efficient energy dissipators (Peterka, 1978).

The energy dissipation structures discussed herein provide a wide range of structures from which to choose the most hydraulically and cost efficient structure. The reader is encouraged to review the analysis, results, and recommendation in Peterka, 1978, prior to the final selection of the energy dissipation structure.

1202.2.2 STILLING BASINS WITH HORIZONTAL SLOPING APRONS

The basis for design of all of the USBR stilling basins is the analysis of the hydraulic jump characteristics on horizontal and sloping aprons. The governing equation for hydraulic jumps is based on pressure-momentum theory and may be written as follows:

$$D_2 / D_1 = 0.5((1 + 8F_{r1}^2)^{0.5} - 1) \tag{1209}$$

where D_1 = Depth of flow at jump entrance (feet)
 D_2 = Depth of flow at jump exit (feet)
 F_{r1} = Froude number at jump entrance

The results of the USBR analysis are presented in Figure 1210. In this figure T_w is the tailwater depth necessary to create or assist in forming the hydraulic jump. Generally, T_w is greater than D_2 .

The above equation is generally used to determine the approximate location of a hydraulic jump in a channel. In practical application, the actual flow depths and location of the jump will vary due to inaccuracies in estimating actual flow parameters (i.e. channel roughness, flow characteristics). The location of the jump will also vary depending on the flow rate in the channel. Therefore, from a structural and safety standpoint, horizontal and sloping apron stilling basins should not be used as energy dissipation structures without the addition of appurtenances (i.e. baffle blocks, end sills, etc.) to control the location of the hydraulic jump. Standard designs for these types of structures are discussed in the following sections.

1202.2.2.1 Short Stilling Basin (USBR Type III)

Presented in Figure 1210 and Figure 1211 is the standard design for a Type III stilling basin. The chute blocks at the upstream end of a basin tend to corrugate the jet; lifting a portion of it from the floor to create a greater number of energy dissipating eddies. These eddies result in a shorter length of jump than would be possible without them, and tend to stabilize the jump. The baffle piers act as an impact dissipation device and the end sill is for scour control. The end sill has little or no effect on the jump. The only purpose of the end sill in a stilling basin is to direct the remaining bottom currents upward and away from the channel bed.

This type of a basin is recommended at the outlet of a sloping channel drop when there is limited available space for a drop structure and adequate tailwater. This basin is relatively

less expensive than other basins under similar hydraulic conditions. For insufficient tailwater, a USBR Type VI basin is recommended.

1202.2.2.2 Low Froude Number Basins (USBR Type IV)

Presented in Figure 1212 is the standard design of a low Froude number basin. The basin is used instead of the USBR Type II and Type III basins in order to achieve better jump characteristic at low Froude numbers ($2.5 < F_r < 4.5$). At these low Froude numbers, excess waves are created because the jump is not fully developed.

This basin minimizes the waves by directing jets from the tops of the baffle blocks into the roller to strengthen and intensify it. In addition, the tail water depth (T_w) should be at least $1.1 \times D_2$ (Conjugate Depth) to minimize the chance of the jump sweeping out of the basin (see Figure 1210). The end sill has little or no effect on the jump but rather directs the bottom currents upward and away from the channel bed.

1202.2.2.3 Impact Stilling Basin (USBR Type VI)

This stilling basin is an impact-type energy dissipator, contained in a relatively small box-like structure, and requiring little or no tailwater for successful performance. The general arrangement of the basin is shown on Figure 1213. This type of basin is subjected to large dynamic forces and turbulences which must be considered in the structural design. The structure should be made sufficiently stable to resist sliding against the impact load on the baffle wall and must resist the severe vibrations. Riprap should also be provided along the bottom and sides adjacent to the structure to avoid the tendency for scour of the outlet channel downstream from the end sill when shallow tailwater exists. This type of stilling basin is very effective at the outlet of storm drains or culverts where there is little or no tailwater.

1202.2.3 HYDRAULIC DESIGN

The three different stilling basin configurations can be divided into two categories, basins for spillways or channels (Type III or IV) and basins for pipe outlets (Type VI). A summary of the design data for all three basin types is presented in Figure 1210. The reader is referred to Peterka, 1978, for a detailed discussion of the structural design requirements.

1202.2.4 RIPRAP PROTECTION

Riprap protection shall be provided downstream of the Type III, IV, and VI stilling basins (except in fully concrete-lined channels). This protection is necessary to protect the downstream channel from erosion due to eddy currents and excess velocities in the transition zone between the structure and the design channel section.

For the Type III and Type IV basin, riprap shall be installed from the end sill a distance of 4 to 10 times the design depth of flow in the downstream channel. The riprap size and thickness shall be designed in accordance with Section 800.

For the Type VI stilling basin, riprap protection shall extend downstream a distance equal to the outlet width, W , of the basin. The minimum downstream distance shall be 5 feet. A 2-foot layer of regular riprap shall be used for all basin widths of 12 feet or less. For basin widths between 12 feet and 20 feet, a 3-foot layer of heavy riprap shall be used. For basin widths greater than 20 feet, a 2-foot layer of grouted riprap shall be used.

1202.2.5 DESIGN FLOW RATES

The effectiveness of energy dissipation structures is dependent on many factors including flow rates, tail water depths, and type of dissipation structure. The structures also must function over a wide range of flow rates typical of stormwater runoff. Therefore, a minimum of the minor and major storm flow rates should be analyzed to assist in protecting the structure against drowning of the hydraulic jump or sweepout of the jump into the downstream channel. The design of the impact stilling basin shall be based on the design flow rate for the upstream pipe or channel.

1202.2.6 TRAJECTORY TRANSITION SECTION

Energy dissipation structures may be designed for either subcritical or supercritical upstream flow conditions. For subcritical flow, an abrupt change in grade at the structure entrance performs satisfactorily. However, for supercritical flow, the flow tends to separate and spring away at any abrupt change in grade. Therefore, to avoid the possibility of flow separation from the channel floor, the floor shape should be flatter than the trajectory of a free discharging flow jet.

Presented in Figure 1214 is a typical design of a trajectory transition section. The curvature of the trajectory section can be determined by the following equation (USBR, 1987).

$$y = x \tan \theta + \frac{x^2}{K(4(d + h_v) \cos^2 \theta)} \tag{1210}$$

- where y = Change in vertical elevation (feet)
- x = Change in horizontal location (feet)
- K = Safety factor
- d = Depth of flow at trajectory entrance (feet)
- h_v = Velocity head at trajectory entrance (feet)
- θ = Slope angle from horizontal of the upstream channel (degrees)

The safety factory, K, should be equal to or greater than 1.5 to assure positive contact pressure.

The trajectory section should be connected to the stilling basin apron by a short, steep chute section. This section should be at a slope between 1.5 horizontal to 1 vertical and 3 horizontal to 1 vertical with 2 horizontal to 1 vertical preferred. In no case should the slope be flatter than 6 horizontal to 1 vertical.

References

- Cedegren, 1967 - H.R. Cedegren, *Seepage Drainage and Flow Nets* (John Wiley and Sons, Inc., New York, 1967).
- Denver Urban Drainage and Flood Control District, 2001 - *Drainage Criteria Manual*.
- Lane, 1935 - E.W. Lane, *Security from Under Seepage* (Transactions ASCE, Vol. 100, 1935).
- Peterka, 1978 - A. J. Peterka, *Hydraulic Design of Stilling Basins and Energy Dissipators, EM No. 25* (US Department of the Interior, Bureau of Reclamation, Denver, Colorado, 1978).
- Smith, 1965 - Smith, C.D., and Murray, D.G., *Cobble Lined Drop Structures* (2nd Canadian Hydro-Technical Conference, Burlington, Ontario, 1965).
- Stevens, 1981 - Stevens, Michael, A., *Hydraulic Design Criteria for Riprap Chutes and Vertical Drop Structures* (Urban Drainage and Flood Control District, 1981).
- Taylor, 1967 - Taylor, D.W., *Fundamentals of Soil Mechanics* (John Wiley and Sons, 1967).
- USACE, 1970 - *Hydraulic Design of Flood Control Channels, EM 1110-2-1601* (US Army Corps of Engineers, Washington, DC, July 1970).
- USBR, 1987 - *Design of Small Dams* (US Department of the Interior, Bureau of Reclamation, Washington, DC, 1987).

CHANNEL DROP AND ENERGY DISSIPATION STRUCTURES

STRUCTURE	1 UPSTREAM FLOW CLASS	2 MAXIMUM ALLOWED DROP HEIGHT (feet)	3 MAXIMUM ALLOWED FLOW RATE (cfs/ft)	4 MAXIMUM ALLOWED INFLOW VELOCITY (fps)	5 BASIN ENTRANCE FROUDE NO.	6 MAXIMUM BASIN ENTRANCE VELOCITY (fps)	7 REQUIRED CROSS- SECTION GEOMETRY	8 REFERENCE FIGURE NUMBER
Sloping Grouted Boulder	SUB	-	-	-	-	-	TRAP.	1202 and 1203
Vertical Riprap Drop	SUB	4	35	7	-	-	TRAP.	1206
Straight Drop	SUB	4	-	-	-	-	RECT.	1208
Baffled Apron (USBR Type IX)	SUB	-	60	12	-	-	RECT.	1209
Short Stilling Basin (USBR Type III)	SUB or SUPER	-	200	-	4.5 to 17	60	RECT.	1211
Low Froude Number Basin (USBR Type IV)	SUB or SUPER	-	-	-	2.5 to 4.5	-	RECT.	1212
Impact Stilling Basin (USBR Type VI)	SUB or SUPER	NA	*	30	NA	50	NA	1213

Column Descriptions

1. SUB = Subcritical ($Fr < 0.8$)
SUPER = Supercritical ($Fr > 1.13$)
 2. Drop height measured from bottom of upstream channel to bottom of downstream channel
 3. Flow Rate = Normal depth (Y_n) multiplied by normal velocity (V_n)
 4. Inflow Velocity = Upstream normal channel velocity
 5. Froude number for flow conditions at entrance to structure apron
 6. Velocity for flow conditions at entrance to structure apron
 7. Cross-section of chute and stilling basin
 8. Reference to figures in this manual
- * Total flow should be less than 400 cfs.

NOTE: Tail water (TW) is measured from invert of basin to water surface in channel immediately downstream of end sill.

VERSION: April 30, 2009	REFERENCE: <p style="text-align: center;">UD&FCD, 1990</p>	TABLE 1201
WTC ENGINEERING, INC.		

SLOPING GROUTED BOULDER DROP DESIGN PARAMETERS

DESIGN PARAMETER	NON-EROSIVE SOILS		EROSIVE SOIL	
	DROP HEIGHT \leq 3 feet	DROP HEIGHT \geq 3 feet	DROP HEIGHT \leq 3 feet	DROP HEIGHT \geq 3 feet
Maximum Slope of Drop, S_d	4 Horizontal to 1 Vertical	4 Horizontal to 1 Vertical	4 Horizontal to 1 Vertical	4 Horizontal to 1 Vertical
Uniform Rock Size, D_u	See Table 1203	See Table 1203	See Table 1203	See Table 1203
Grout Thickness, D_1	See Table 1203	See Table 1203	See Table 1203	See Table 1203
Basin Thickness, D_1	2.0 feet for $Q \leq 1000$ cfs 1.75 feet for $1000 \text{ cfs} < Q \leq 3000$ cfs 1.5 feet for $Q > 3000$ cfs	2.25 feet for $Q \leq 1000$ cfs 2.0 feet for $1000 \text{ cfs} < Q \leq 3000$ cfs 1.75 feet for $Q > 3000$ cfs	1.75 feet for $Q \leq 1000$ cfs 1.5 feet for $1000 \text{ cfs} < Q \leq 25000$ cfs 1.0 feet for $Q > 25000$ cfs	1.75 feet for $Q \leq 1000$ cfs 1.5 feet for $1000 \text{ cfs} < Q \leq 25000$ cfs 1.0 feet for $Q > 25000$ cfs
Grouted Rock Approach, Apron L_2	5 feet for $Q \leq 1000$ cfs 10 feet for $1000 \text{ cfs} < Q \leq 3000$ cfs 15 feet for $3000 \text{ cfs} < Q \leq 7500$ cfs	5 feet for $Q \leq 1000$ cfs 10 feet for $1000 \text{ cfs} < Q \leq 3000$ cfs 15 feet for $3000 \text{ cfs} < Q \leq 7500$ cfs	5 feet for $Q \leq 500$ cfs 10 feet for $500 \text{ cfs} < Q \leq 1000$ cfs 15 feet for $1000 \text{ cfs} < Q \leq 2000$ cfs 20 feet for $2000 \text{ cfs} < Q \leq 75000$ cfs	5 feet for $Q \leq 500$ cfs 10 feet for $500 \text{ cfs} < Q \leq 1000$ cfs 15 feet for $1000 \text{ cfs} < Q \leq 2000$ cfs 20 feet for $2000 \text{ cfs} < Q \leq 75000$ cfs
Basin Length, L_2^*	5+TW depth but not less than 20 feet	5+TW depth but not less than 25 feet	5+TW depth but not less than 20 feet	6+TW depth but not less than 25 feet
Channel Width, b_1	See Section 800	See Section 800	See Section 800	See Section 800
Slope face length, L_1	S_d Drop Height	S_d * Drop Height	S_d * Drop Height	S_d Drop Height
Length of flat slope directly upstream of Crest	13 feet	13 feet	15 feet	15 feet
Grouted rock exist Apron, L_1	10 feet min.	10 feet min.	10 feet min.	10 feet min.

* For submerged drops add 10 feet to the length or use a hydraulic jump analysis to refine the main basin length.

VERSION: April 30, 2009

WTC ENGINEERING, INC.

REFERENCE:

UD&FCD, 1990

TABLE
1202

SLOPING GROUTED BOULDER DROP ROCK AND GROUT THICKNESS

DEPTH OF ROCK LAYER WHICH IS EQUIVALENT TO THE MINIMUM BOULDER SIZE, D_r (Inches)	DEPTH OF GROUT LAYER, D_g (Inches)
18	12
24	18
30	24
36	28
42	32

VERSION: April 30, 2009	REFERENCE:	TABLE
WTC ENGINEERING, INC.	UD&FCD, 1990	1203

DROP STRUCTURES

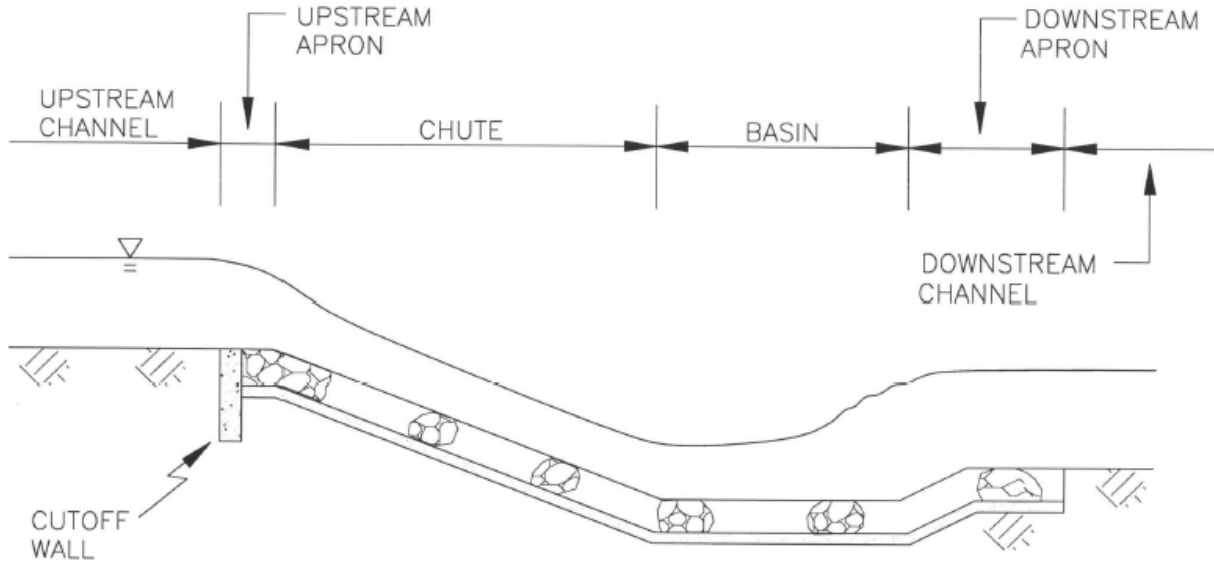

A. SLOPING CHANNEL DROP

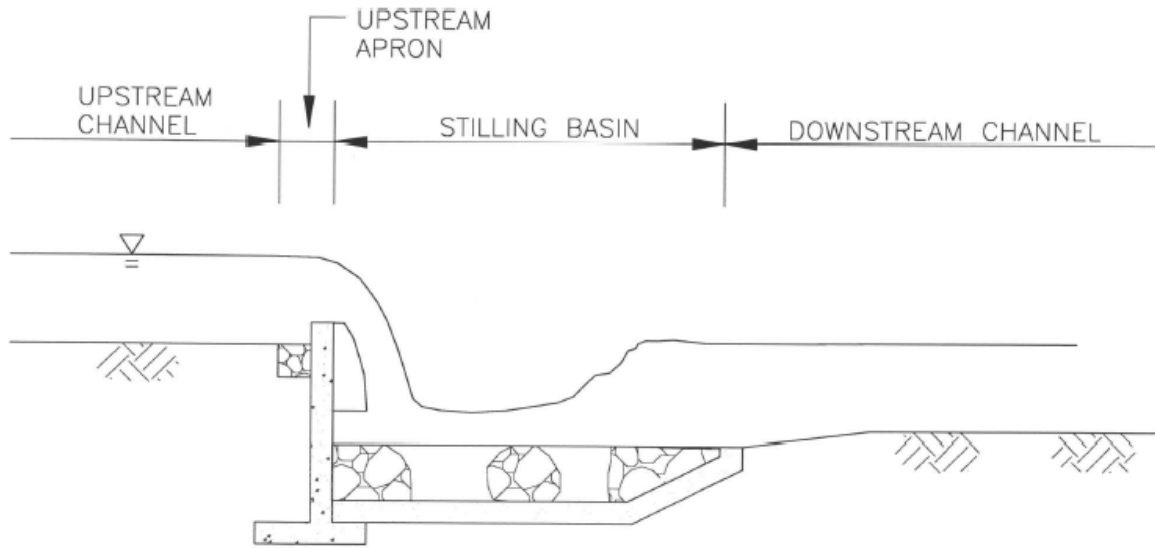

B. VERTICAL CHANNEL DROP

SLOPING GROUTED BOULDER DROP

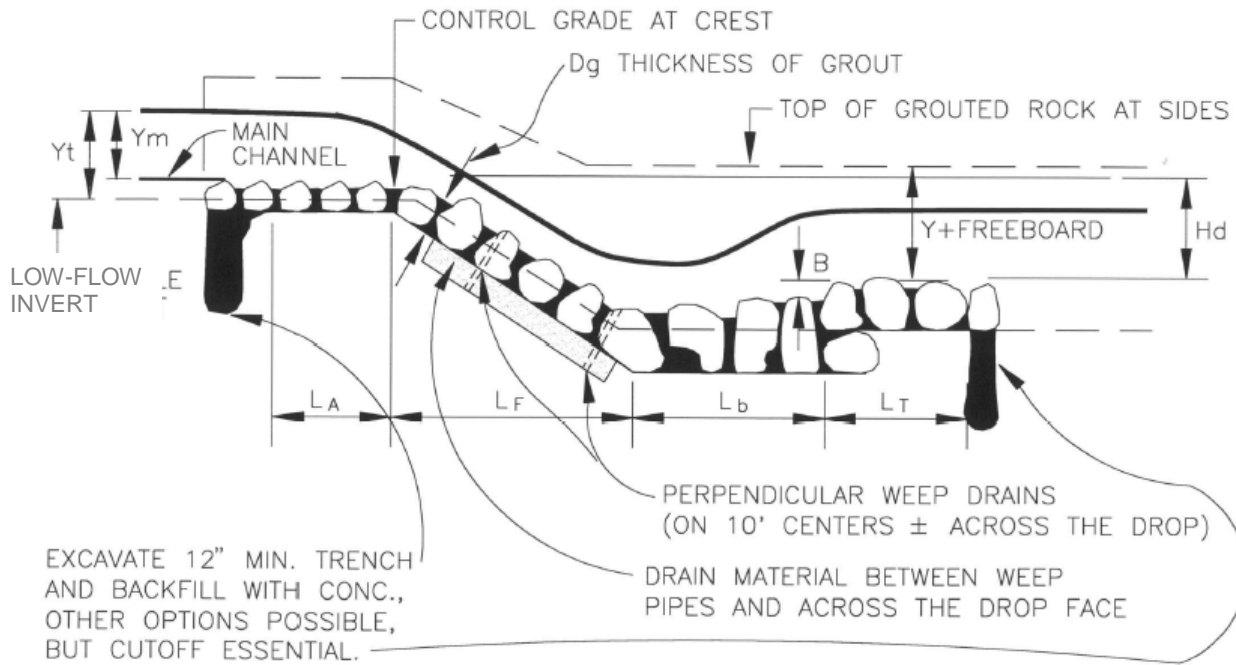

PROFILE

OUTLINE OF PROJECTING BOULDER DOWNSTREAM 0.6 TO 0.8 OF Y_c IN LOW-FLOW

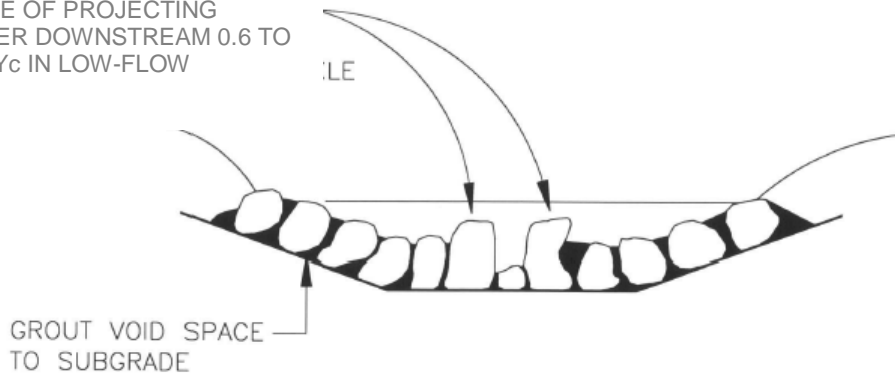

SECTION A

VERSION: April 30, 2009

REFERENCE:

FIGURE 1202

WTC ENGINEERING, INC.

SLOPING GROUDED BOULDER DROP SCHEMATIC

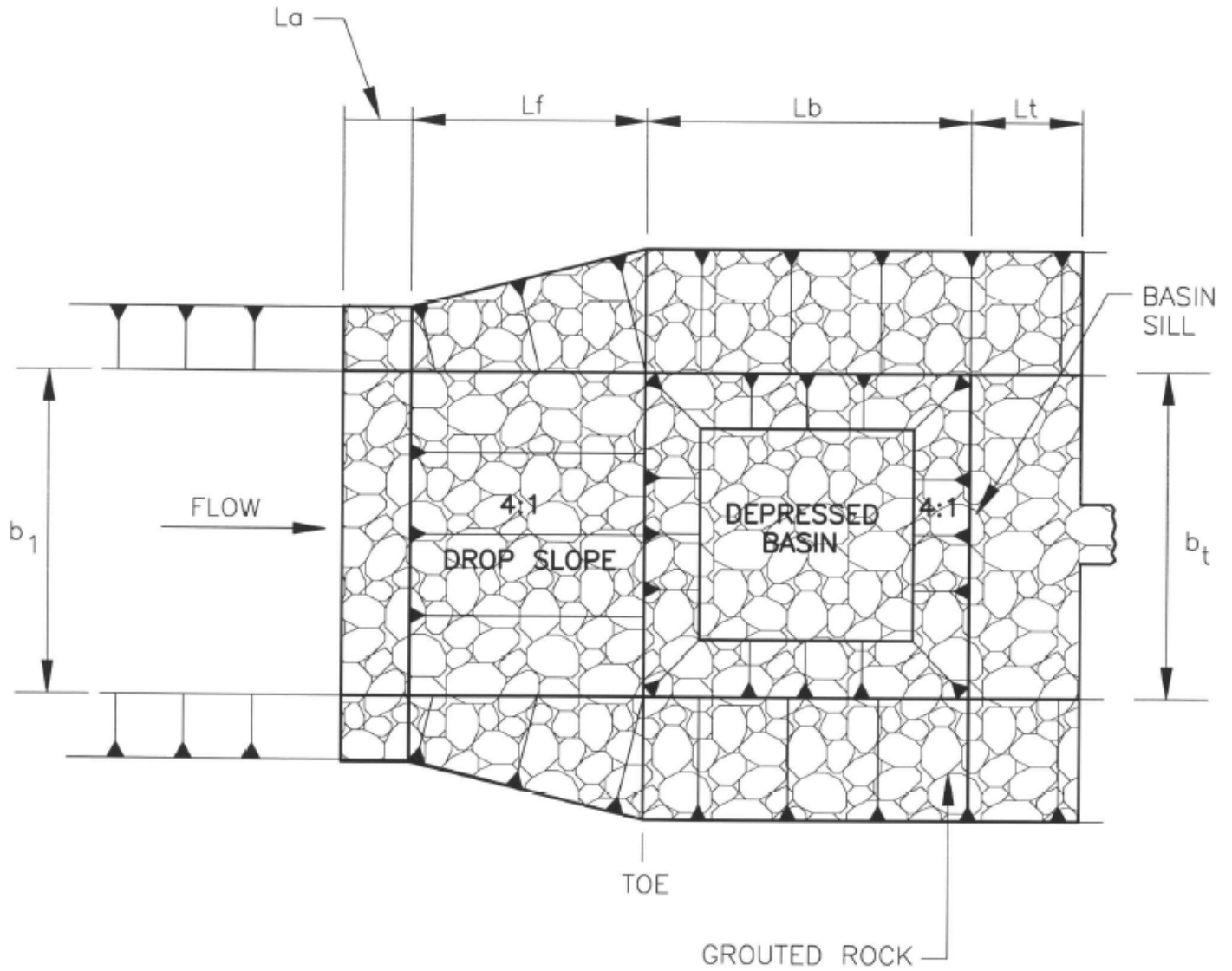

NOTE:
See Table 1202 for definitions and values of design parameter

VERSION: April 30, 2009

REFERENCE:

FIGURE
1203

WTC ENGINEERING, INC.

TYPICAL GROUTED BOULDER PLACEMENT

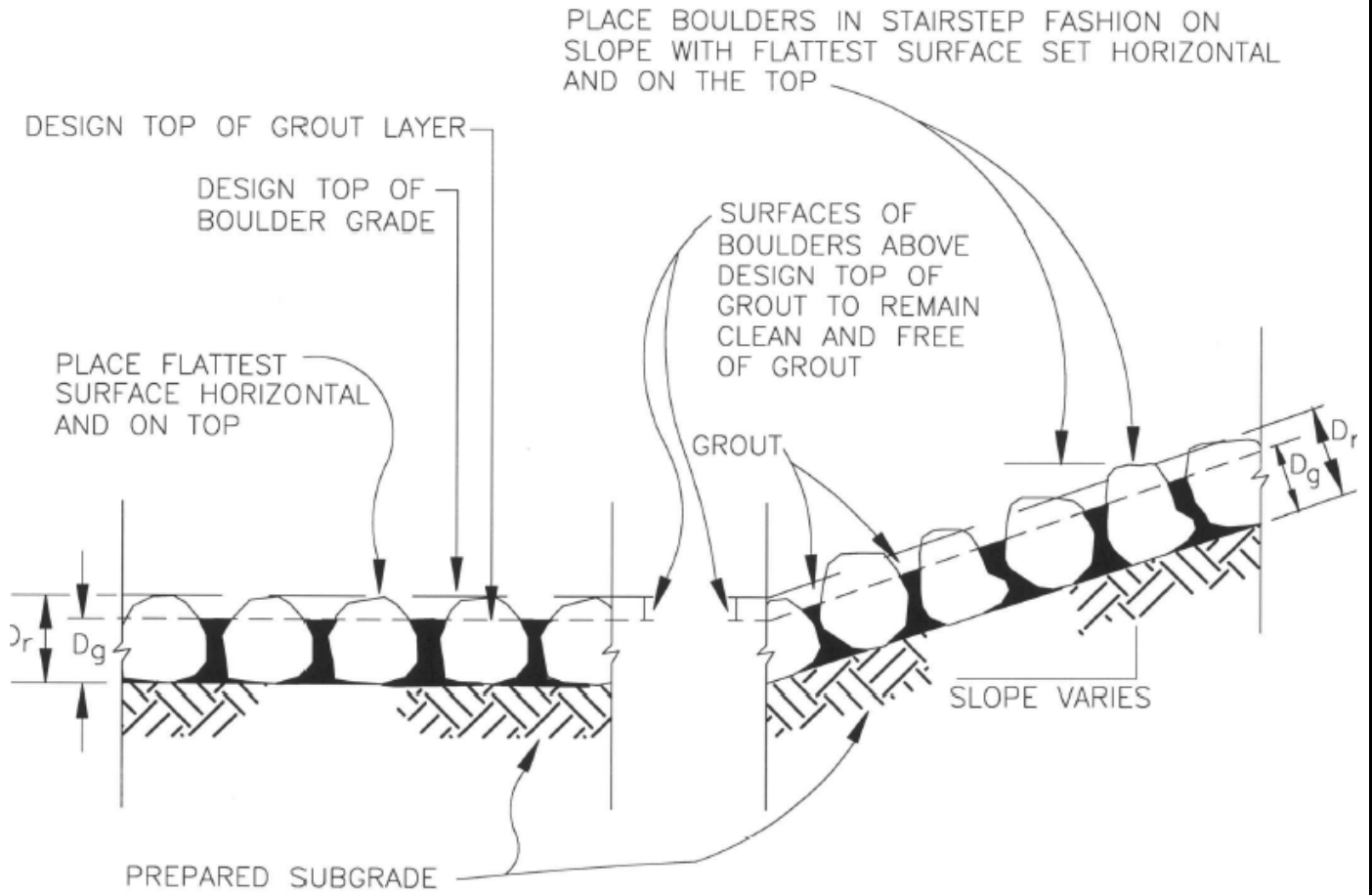

D_r = DEPTH OF ROCK LAYER WHICH IS EQUIVALENT TO THE MINIMUM BOULDER SIZE

D_g = DEPTH OF GROUT LAYER

VERSION: April 30, 2009

REFERENCE:

FIGURE
1204

WTC ENGINEERING, INC.

WEEP DRAIN SYSTEM DETAILS

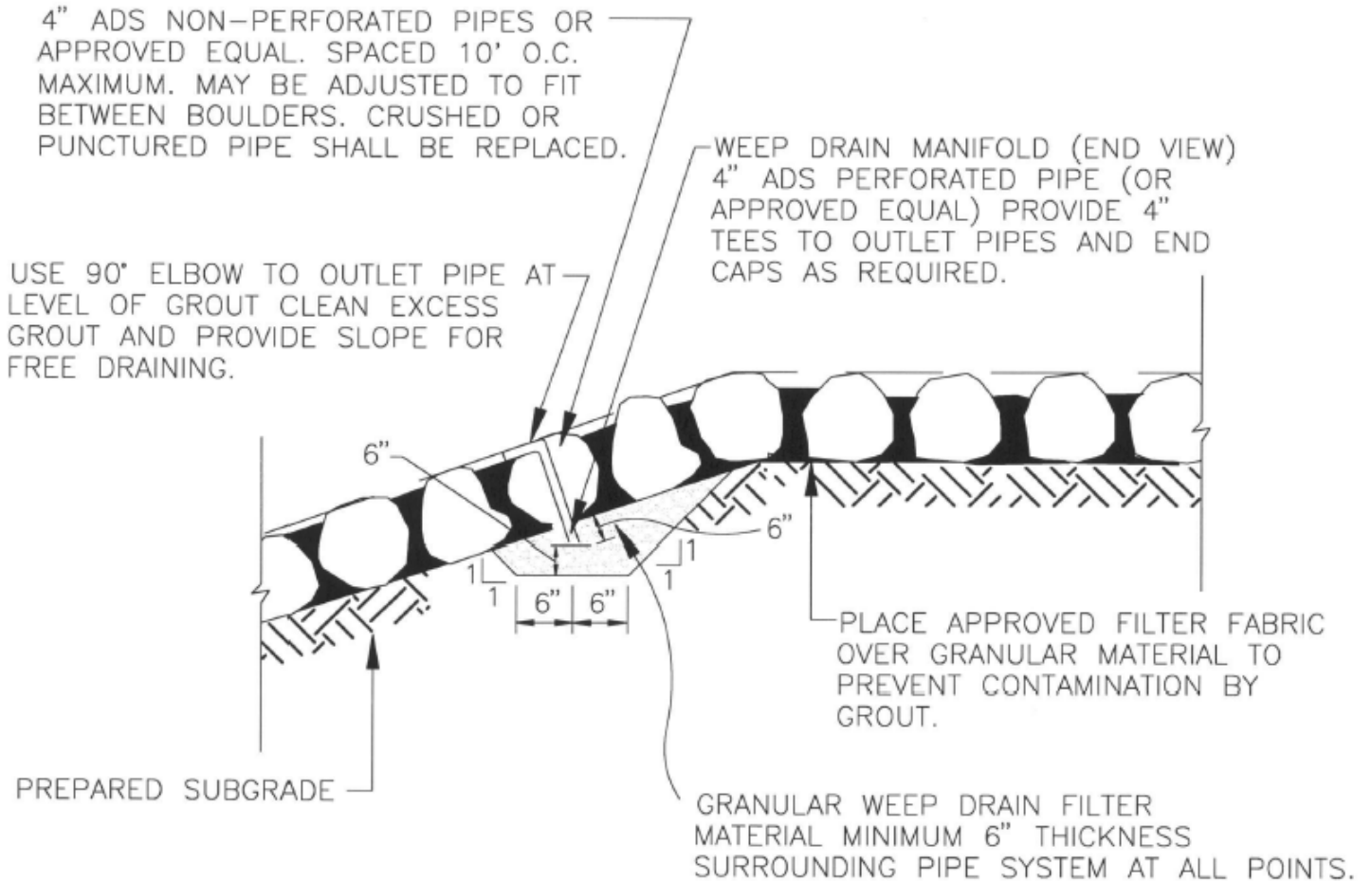

VERSION: April 30, 2009

REFERENCE:

FIGURE
1205

WJC ENGINEERING, INC.

VERTICAL RIPRAP DROP

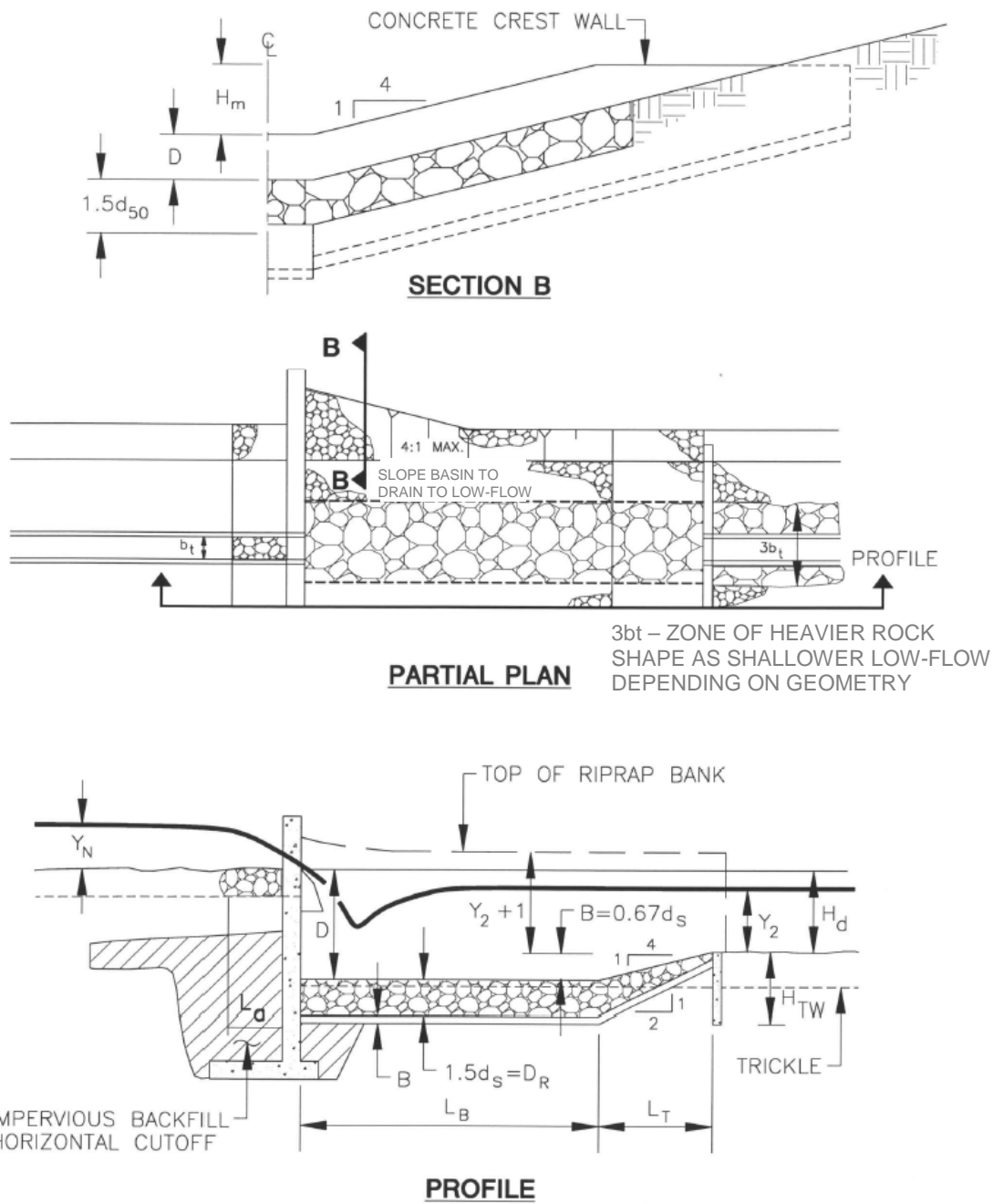

3bt – ZONE OF HEAVIER ROCK SHAPE AS SHALLOWER LOW-FLOW DEPENDING ON GEOMETRY

VERSION: April 30, 2009

REFERENCE:

McLaughlin Water Engineers, 1986

FIGURE

1206

WTC ENGINEERING, INC.

CURVES FOR SCOUR DEPTH AT VERTICAL DROP

NUMBERS ON CURVES ARE VALUES OF Y_2/D

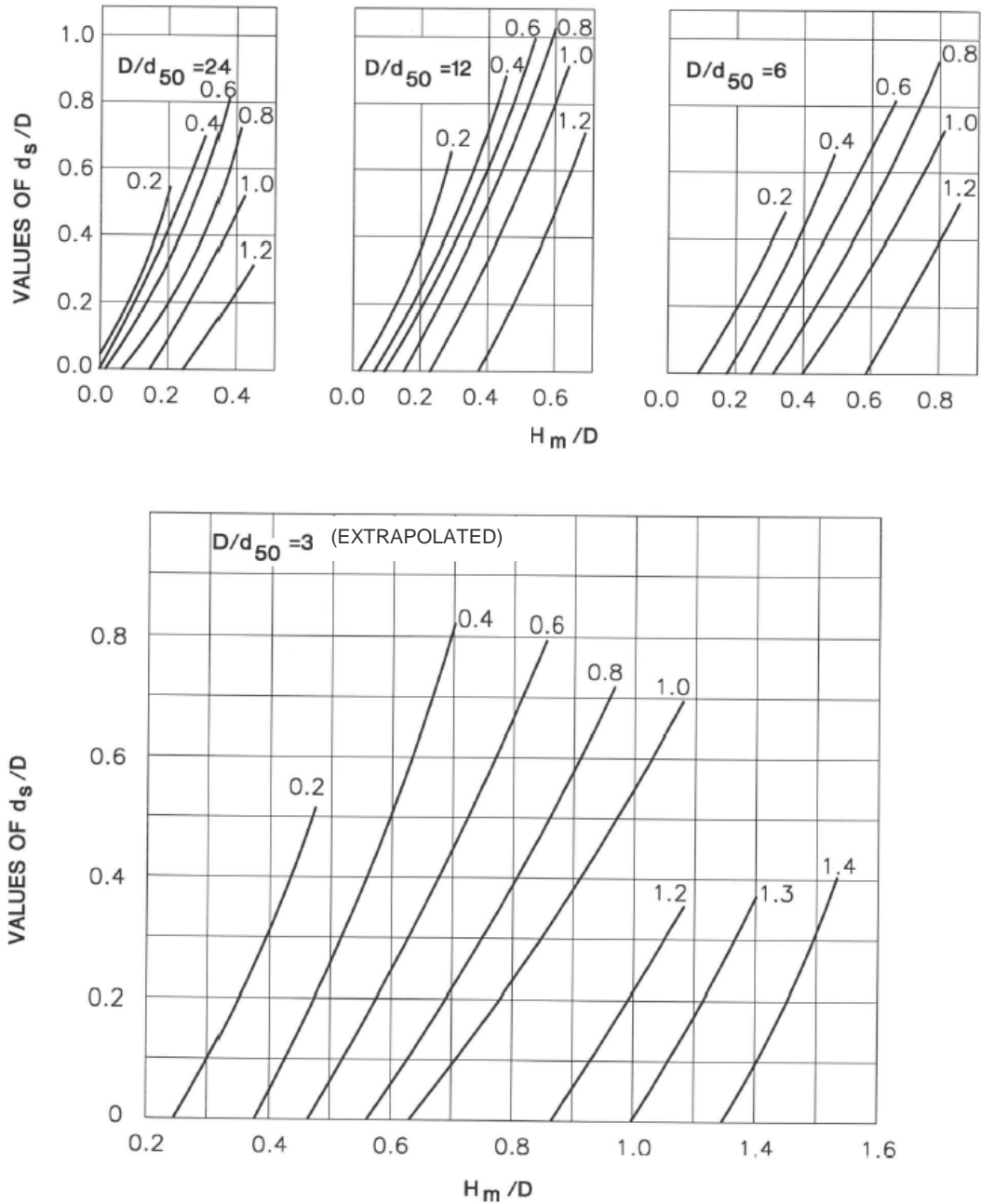

VERSION: April 30, 2009

W7C ENGINEERING, INC.

REFERENCE:

McLaughlin Water Engineers, Ltd., *Evaluation of and Design Recommendations for Drop Structures in the Denver Metropolitan Area*, December 1986

FIGURE 1207

WASHOE COUNTY
HYDROLOGIC CRITERIA AND DRAINAGE DESIGN MANUAL

STRAIGHT DROP SPILLWAY

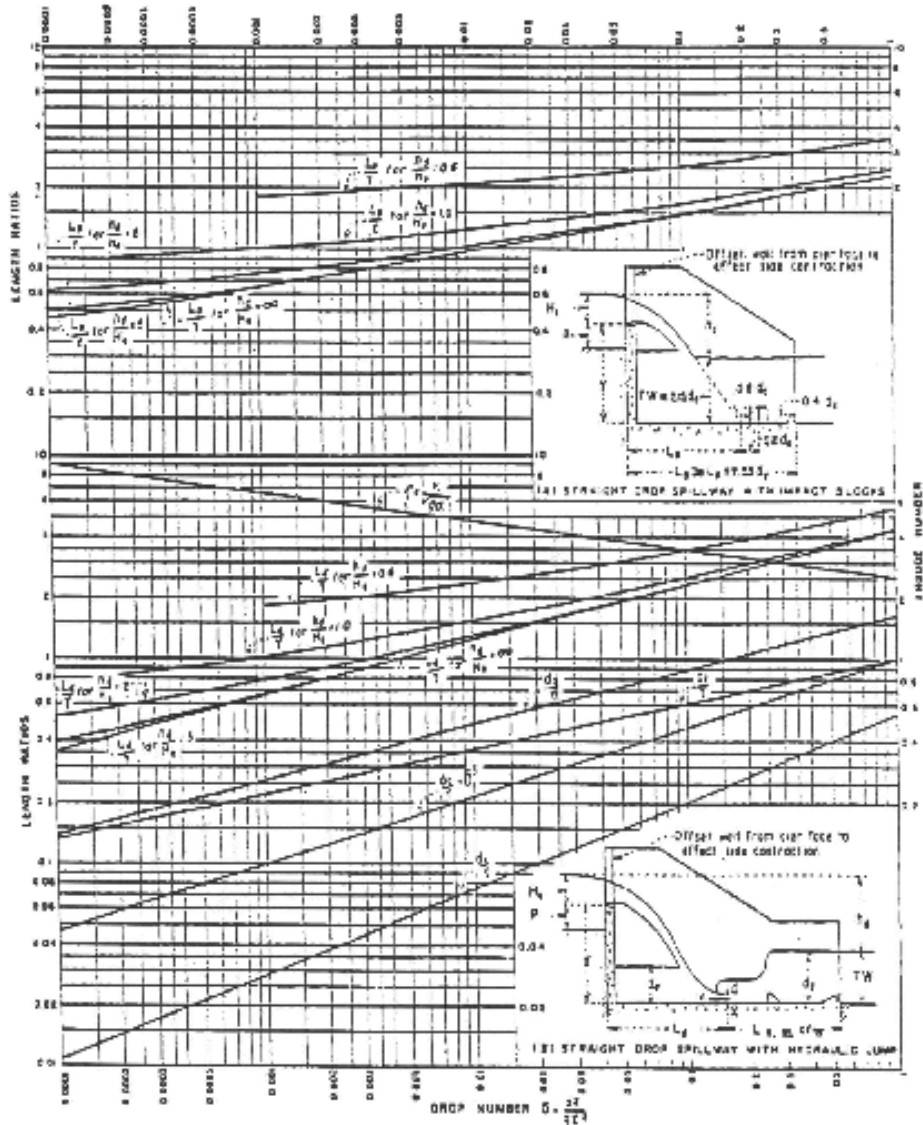

**BAFFLED APRON STILLING BASIN
(USBR TYPE IX)**

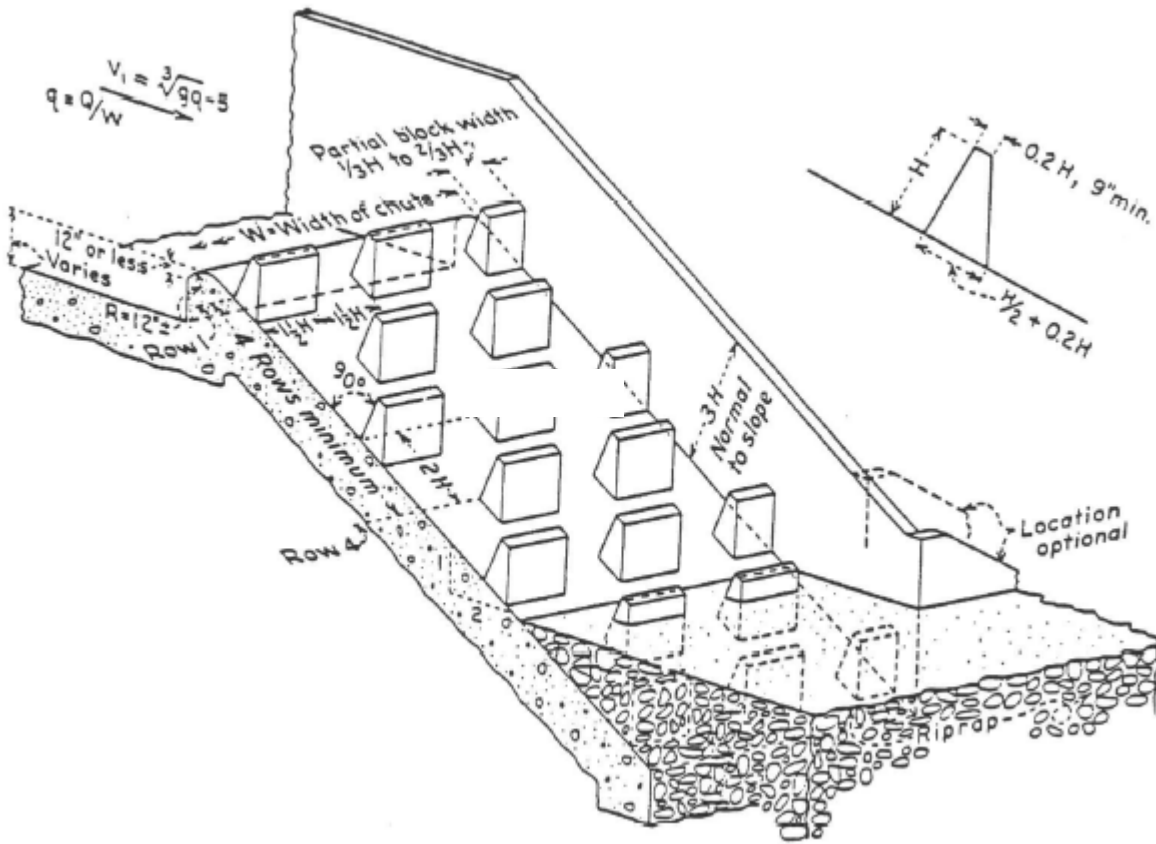

NOTE:
See Figure 1210 for design data

VERSION: April 30, 2009

WTC ENGINEERING, INC.

REFERENCE:

US Bureau of Reclamation, *Hydraulic Design of Stilling Basins and Energy Dissipators*, EM25 BR, January 1978

FIGURE
1209

WASHOE COUNTY

HYDROLOGIC CRITERIA AND DRAINAGE DESIGN MANUAL

DESIGN DATA-USBR TYPE STILLING BASINS

GENERAL INVESTIGATION OF THE HYDRAULIC JUMP ON HORIZONTAL APRONS (BASIN I)

Jump occurs on flat floor with no chute blocks, baffle piers or end sill in basin. Usually not a practical basin because of excessive length. Elements and characteristics of jumps for complete range of Froude numbers is determined so that designers in choosing more practical basins II, III, IV, V, and VI.

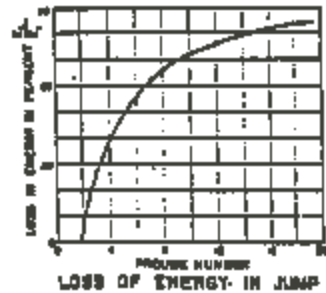
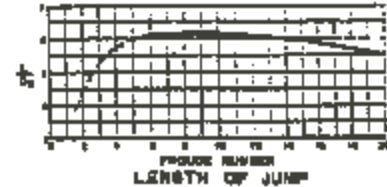
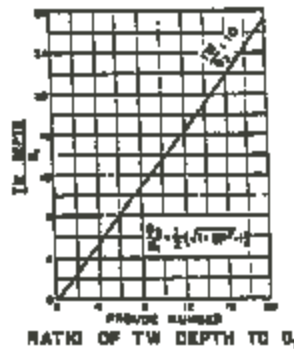
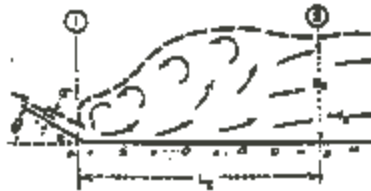

STILLING BASIN WITH SLOPING APRON (BASIN V)

For use where structural economies dictate desirability of sloping apron, usually on high dam spillways. Needs greater tailwater depth than horizontal apron.



(CASE A)



(CASE B)

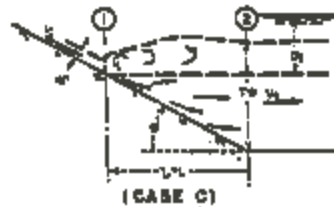

(CASE C)



(CASE D)

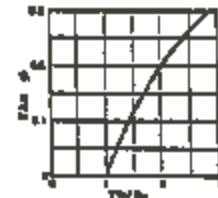

TAILWATER DEPTH RELATED TO CONJUGATE DEPTH (CASE D)

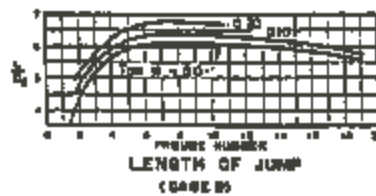

(CASE B)

VERSION: April 30, 2009

WRC ENGINEERING INC

REFERENCE:

"HYDRAULIC DESIGN OF STILLING BASINS AND ENERGY DISSIPATORS," EM25 BR, JANUARY 1978

FIGURE 1210
1 OF 3

WASHOE COUNTY
HYDROLOGIC CRITERIA AND DRAINAGE DESIGN MANUAL

DESIGN DATA-USBR TYPE STILLING BASINS

BAFFLED APPROX FOR CANAL OR SPILLWAY DROPS (BASIN IX)

For use in flow ways where water is to be lowered from one level to another. The baffle piers prevent undue acceleration of the flow and it usually drops the grade. Since the flow velocity entering the downstream channel are relatively low, no stiling basin is required. The chute may be designed to dissipate 25 to 30 cubic feet per second per foot of width, and the drop may be as high as structurally feasible.

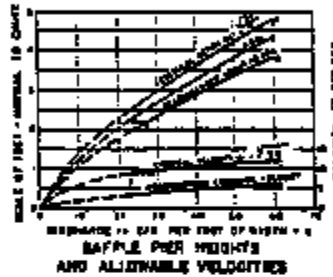
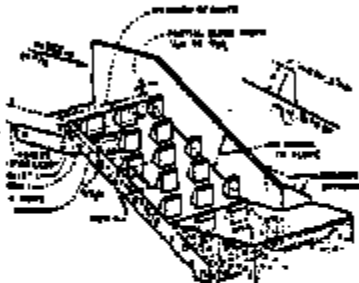

DESIGN PROCEDURE

The baffled apron should be designed for the maximum expected discharge, Q , up to 60 cfs. per foot of width.

Entrance velocity V_1 should be below the practical $0.75 \sqrt{h_1}$.

See Figures 103, 104, 105 and 106 for some typical drops.

Baffle pier height, h , should be about 0.50 to 0.75 h_1 , h_1 being the depth.

Baffle pier width and spacing should be equal, up to 1/2 ft., but not less than 1/4 ft.

The clear distance between rows of baffle piers should be 20 ft., from the baffle edge to the next row for drops in row spacing for drops.

Four rows of baffle piers are required to establish full control of the flow, although fewer rows have operated successfully at least one row of baffle piers should be placed in the middle.

The chute apron width should be three times as high as the baffle pier.

Ward consistency of a stilling basin should be placed at the downstream end of the apron to prevent eddies from undermining the walls.

STILLING BASIN FOR PIPE OR OPEN CHANNEL OUTLET (BASIN VI)

For use at end of open channel outlet. Spill and discharge from pipe is shown as 20 feet per second. The maximum required P.O.D. number usually is 10. This may vary.

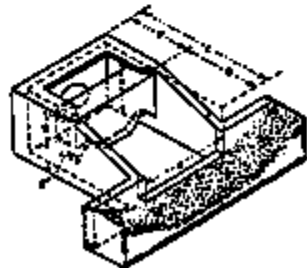

FEET AND INCHES	1	2	3	4	5	6	7	8	9	10
10 - 1 1/2	1 1/2	2 1/2	3 1/2	4 1/2	5 1/2	6 1/2	7 1/2	8 1/2	9 1/2	10 1/2
20 - 2 1/2	2 1/2	3 1/2	4 1/2	5 1/2	6 1/2	7 1/2	8 1/2	9 1/2	10 1/2	11 1/2
30 - 3 1/2	3 1/2	4 1/2	5 1/2	6 1/2	7 1/2	8 1/2	9 1/2	10 1/2	11 1/2	12 1/2
40 - 4 1/2	4 1/2	5 1/2	6 1/2	7 1/2	8 1/2	9 1/2	10 1/2	11 1/2	12 1/2	13 1/2
50 - 5 1/2	5 1/2	6 1/2	7 1/2	8 1/2	9 1/2	10 1/2	11 1/2	12 1/2	13 1/2	14 1/2
60 - 6 1/2	6 1/2	7 1/2	8 1/2	9 1/2	10 1/2	11 1/2	12 1/2	13 1/2	14 1/2	15 1/2
70 - 7 1/2	7 1/2	8 1/2	9 1/2	10 1/2	11 1/2	12 1/2	13 1/2	14 1/2	15 1/2	16 1/2
80 - 8 1/2	8 1/2	9 1/2	10 1/2	11 1/2	12 1/2	13 1/2	14 1/2	15 1/2	16 1/2	17 1/2
90 - 9 1/2	9 1/2	10 1/2	11 1/2	12 1/2	13 1/2	14 1/2	15 1/2	16 1/2	17 1/2	18 1/2
100 - 10 1/2	10 1/2	11 1/2	12 1/2	13 1/2	14 1/2	15 1/2	16 1/2	17 1/2	18 1/2	19 1/2

BASIC DIMENSIONS

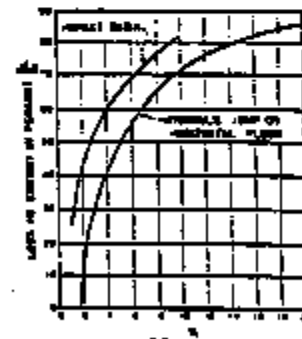
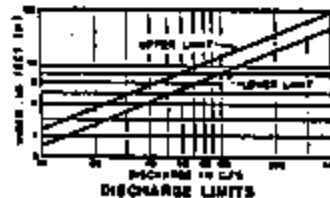

COMPARISON OF ENERGY LOSSES

VERSION: April 30, 2009

WRC ENGINEERING INC

REFERENCE:

"HYDRAULIC DESIGN OF STILLING BASINS AND ENERGY DISSIPATORS," EM25 BR, JANUARY 1978

FIGURE
1210
2 OF 3

WASHOE COUNTY
HYDROLOGIC CRITERIA AND DRAINAGE DESIGN MANUAL

DESIGN DATA-USBR TYPE STILLING BASINS

STILLING BASIN DESIGN AND WAVE SUPPRESSORS FOR CANAL STRUCTURES, OUTLET WORKS, AND DIVERSION DAMS (BASIN IV)

For use with jumps of Froude number 2.8 to 4.5 which usually occur on small structures and diversion dams. They basin reduces excessive wave growth in impeller jumps.
May also use alternative design and for wave suppressors shown below, or Basin VI.

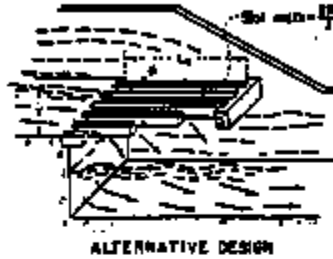
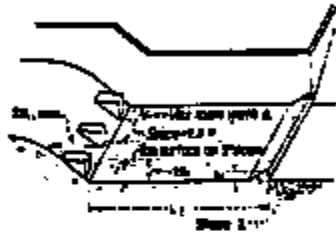

ALTERNATIVE DESIGN



RAFT TYPE



IMPELLER TYPE WAVE SUPPRESSORS

SHORT STILLING BASINS FOR CANAL STRUCTURES, SMALL OUTLET WORKS AND SMALL SPILLWAYS (BASIN III)

Jump and basin length reduced about 80 percent with cone blocks, baffle plate, and side sill.
For use on small spillways, outlet works, and small structures where a dam has failed 80-90 feet per second and Froude number is about 4.5.



LENGTH OF JUMP

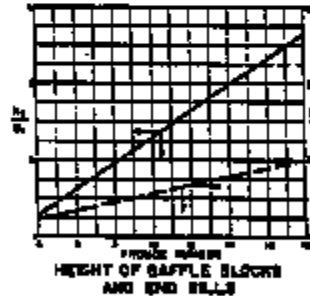

HEIGHT OF BAFFLE BLOCKS AND END SILLS



WATER SURFACE AND PRESSURE PROFILES

VERSION: April 30, 2009

WRC ENGINEERING INC

REFERENCE:

"HYDRAULIC DESIGN OF STILLING BASINS AND ENERGY DISSIPATORS," EM25 BR, JANUARY 1978

FIGURE
1210
3 OF 3

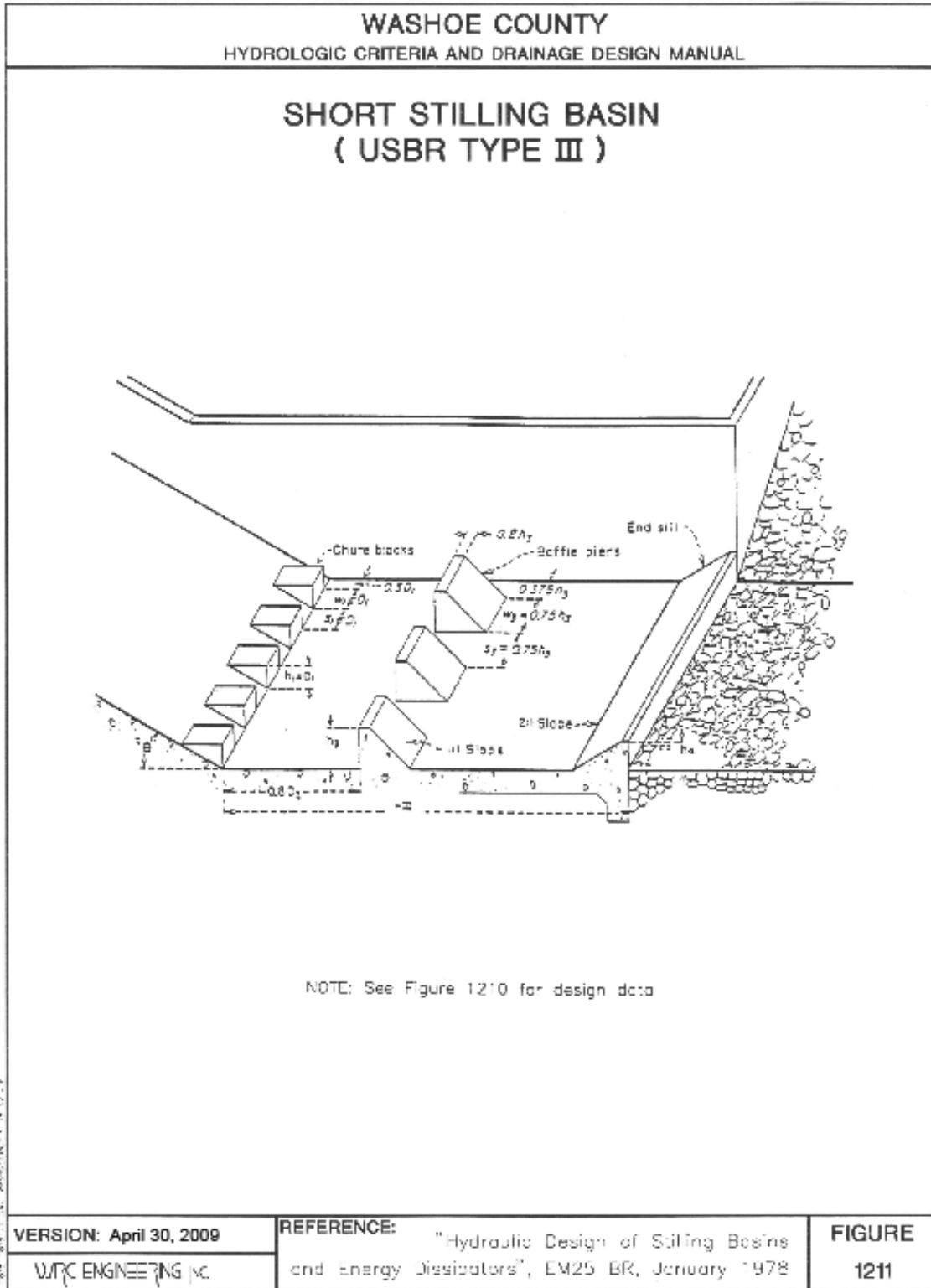

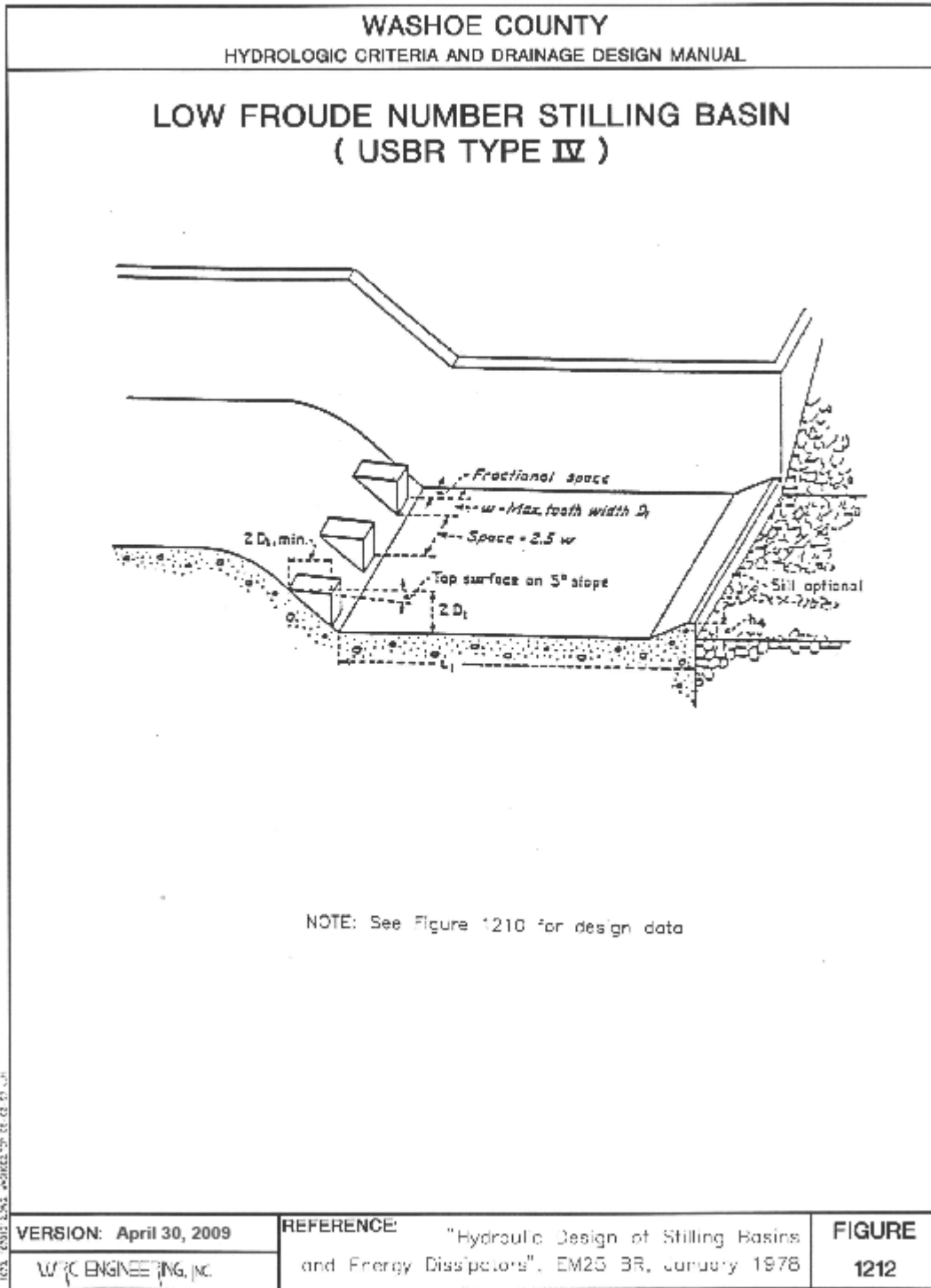

1073, 10712, 10713, 10714, 10715, 10716, 10717, 10718, 10719, 10720, 10721, 10722, 10723, 10724, 10725, 10726, 10727, 10728, 10729, 10730, 10731, 10732, 10733, 10734, 10735, 10736, 10737, 10738, 10739, 10740, 10741, 10742, 10743, 10744, 10745, 10746, 10747, 10748, 10749, 10750, 10751, 10752, 10753, 10754, 10755, 10756, 10757, 10758, 10759, 10760, 10761, 10762, 10763, 10764, 10765, 10766, 10767, 10768, 10769, 10770, 10771, 10772, 10773, 10774, 10775, 10776, 10777, 10778, 10779, 10780, 10781, 10782, 10783, 10784, 10785, 10786, 10787, 10788, 10789, 10790, 10791, 10792, 10793, 10794, 10795, 10796, 10797, 10798, 10799, 10800

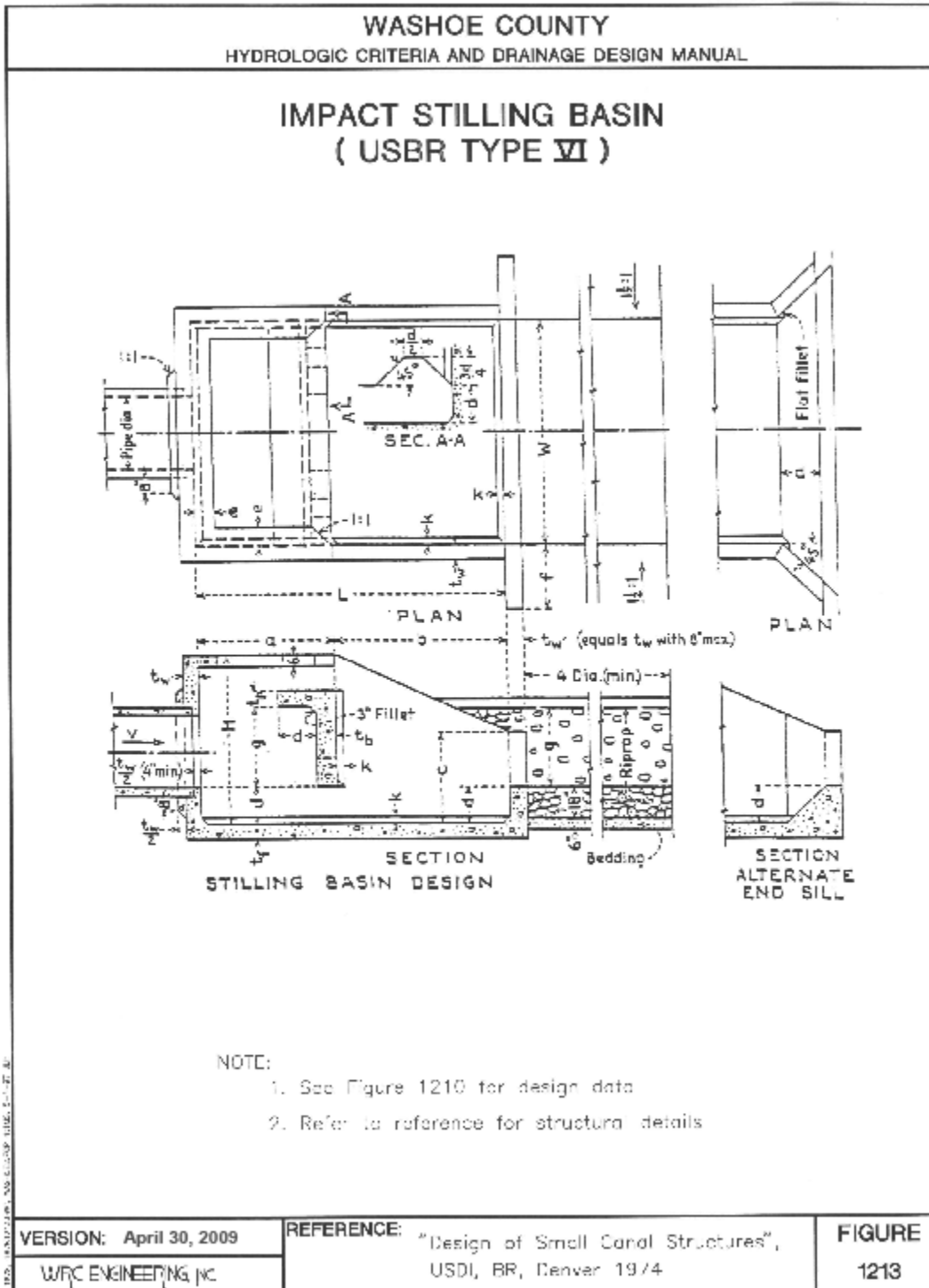

WASHOE COUNTY
HYDROLOGIC CRITERIA AND DRAINAGE DESIGN MANUAL

TYPICAL TRAJECTORY TRANSITION

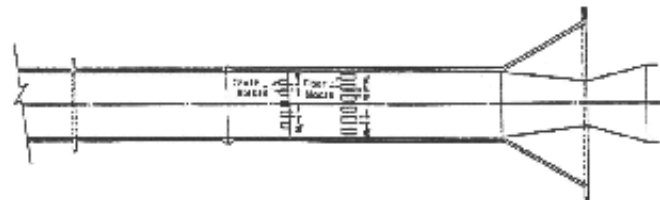

PLAN

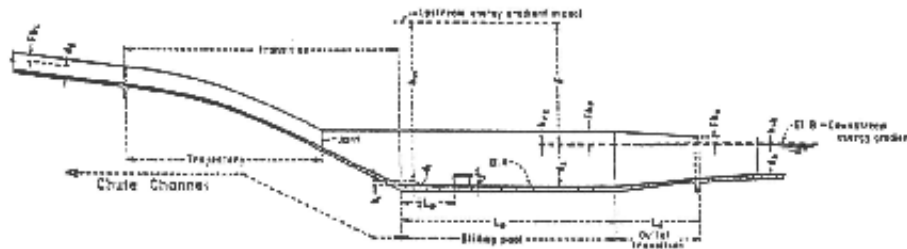

PROFILE

EXPLANATION

- 1..... Proposed bottom of trajectory of hydraulic jump.
- 2..... Vertical mark at beginning of hydraulic jump.
- 3..... Depth of pool of hydraulic jump.
- 4..... Velocity mark at end of hydraulic jump.
- 5..... Normal water depth in reach of control structure.
- 6..... Velocity mark for pool or control structure.
- 7..... Maximum turbulent water depth in chute channel.
- 8..... Height of flow marks.
- 9..... Height of flow marks in pool.
- 10..... Width and spacing of chute and pool flow marks.
- L1, L2, L3..... Pool and outlet lengths as determined by recommendations and hydraulic relationships.
- L4..... Length of sliding pool as determined by pressure and hydraulic relationships.
- Ph..... Proposed minimum pool.
- Pb..... Proposed minimum.
- Pc..... Proposed minimum transition.
- Pd..... Proposed minimum hydraulic jump.
- El. A..... elevation at sliding jump invert.

REV. 12/10/2009 AND 02/21/11 1214-1

VERSION: April 30, 2009
WTC ENGINEERING, PC.

REFERENCE: "Canals and Related Structures",
Design Standards No. 3, USBR, 1967

FIGURE
1214

SECTION 1300 - DETENTION

TABLE OF CONTENTS

	<u>Page</u>
1301 INTRODUCTION	1302
1301.1 DEFINITION OF REGIONAL FACILITIES	1302
1301.2 DEFINITION OF LOCAL FACILITIES	1302
1302 DETENTION/RETENTION DESIGN GUIDELINES AND STANDARDS	1303
1302.1 REGIONAL DETENTION.....	1303
1302.2 LOCAL DETENTION.....	1304
1303 HYDROLOGIC DESIGN METHODS AND CRITERIA	1306
1303.1 INFLOW HYDROGRAPH	1306
1303.2 DETENTION BASIN DESIGN OUTFLOW LIMITATIONS	1306
1303.3 HYDROLOGIC CALCULATION METHODS.....	1307
1304 OUTLET STRUCTURES	1308
1304.1 LOW FLOW OUTLETS.....	1308
1304.2 SPILLWAYS	1310
1305 DEBRIS AND SEDIMENTATION.....	1311
1305.1 TRASH RACKS	1311
1305.2 SEDIMENTATION.....	1311
1305.3 SEDIMENT YIELD ESTIMATION	1312
1306 DESIGN STANDARDS AND CONSIDERATIONS.....	1315
1306.1 DAM SAFETY	1315
1306.2 GRADING REQUIREMENTS	1315
1306.3 DEPTH LIMITS	1315
1306.4 LOW FLOW AND BASIN DEWATERING	1315
1306.5 EMBANKMENT PROTECTION	1315
1306.6 MAINTENANCE REQUIREMENTS.....	1315
1306.7 LOCAL DETENTION BASIN SITING GUIDELINES	1316
1307 EXAMPLE APPLICATIONS	1316
1307.1 EXAMPLE: DETENTION POND OUTLET SIZING.....	1316
1307.2 EXAMPLE: RATIONAL FORMULA DETENTION METHOD	1317

LIST OF TABLES

1301 CONSERVATION PRACTICE FACTOR P FOR CONTOURING, STRIP CROPPING AND TERRACING
1302 INFLOW HYDROGRAPH AND BASIN CHARACTERISTICS FOR EXAMPLE IN SECTION 1307.1
1303 HEC-1 RUN FOR EXAMPLE IN SECTION 1307.1

LIST OF FIGURES

- 1301 TYPICAL BASIN GEOMETRY
- 1302 V-NOTCH WEIR COEFFICIENTS
- 1303 OGEE-CRESTED WEIR COEFFICIENTS
- 1304 SOIL ERODIBILITY NOMOGRAPH USED TO DETERMINE FACTOR K (TONS/ACRE) FOR SPECIFIC TOPSOILS OR SUBSOIL HORIZONS
- 1305 FACTOR FOR CANOPY EFFECT
- 1306 EFFECT OF PLANT RESIDUES OR CLOSE-GROWING STEMS AT THE SOIL SURFACE
- 1307 TYPE III EFFECTS ON UNDISTURBED LAND AREAS
- 1308 HYDROGRAPH FOR EXAMPLE IN SECTION 1307.2

SECTION 1300

DETENTION

1301 INTRODUCTION

The main purpose of a detention basin is to temporarily store runoff and reduce peak discharge by allowing flow to be discharged at a controlled rate. This controlled discharge rate is based on either limited downstream capacity (regional and local facilities) or on a limit on the increase in flows over predevelopment conditions (local facilities only). Regional and local detention facilities are more fully discussed below. The Jurisdictional Entity Policies regarding detention basin design is presented in the “Policy” Section 303.7.

1301.1 DEFINITION OF REGIONAL FACILITIES

Regional detention facilities are those identified in the current Washoe County Flood Control Master Plan or as designated by the Jurisdictional Entities. Generally, these facilities control flow on major drainageways, are of major proportion, and are funded by public agencies. The purpose of these facilities is to significantly reduce downstream flows in order to maximize the capacity of existing systems and maintain flows at or below historic rates.

1301.2 DEFINITION OF LOCAL FACILITIES

Local detention facilities are usually designed by and financed by developers or local property owners. The facilities are intended to allow development by protecting a site from existing flooding conditions or to protect downstream property from increased runoff caused by development. Two classes of local facilities are defined below.

1301.2.1 LOCAL MINOR FACILITIES

Local minor detention facilities are defined as serving hydrologic basins smaller than or equal to 20 acres, and are designed to mitigate the impact of increased runoff due to development. The outlet capacity is generally based on pre-development hydrology and downstream conveyance system capacity and the structures are generally small (0.01 to 1 acre-feet). Detention storage volume may be provided as small landscaped or turfed basins, parking lot storage, roof top storage, or a suitable combination of all three.

1301.2.2 LOCAL MAJOR FACILITIES

Local major detention facilities are defined as serving hydrologic basins greater than 20 acres. These facilities may serve a double function. They are required to reduce existing flooding to allow development and/or control increased runoff caused by the development. These facilities may store significant flood volumes and will generally be funded by the developer. They may handle both off-site and on-site flows. Due to their significant size, these basins are designed much the same as regional detention facilities.

1302 DETENTION/RETENTION DESIGN GUIDELINES AND STANDARDS

Certain guidelines for detention basin design need to be identified in order to properly design facilities. These guidelines cover items such as outlet flows, spillway sizing, and sedimentation. The following sections describe major guidelines governing detention basin designs.

1302.1 REGIONAL DETENTION

The design of regional detention facilities shall be coordinated with the Jurisdictional Entity. The Nevada State Engineer must review detention basins which require dams, for which an application must be filed. If the embankments are greater than 20 feet in height or impounding is over 20 acre-feet of movable material, a permit from the State Engineer's Office is needed. Regional detention guidelines include:

1. Regional detention basins are preferred to smaller local detention basins.
2. Off-channel detention basins are preferred.
3. Multi-use (e.g., recreation) can be considered in the design of detention basins.
4. Below-grade detention basins are preferred to above-grade facilities.
5. Basins should be sited on publicly-owned lands whenever possible.

Regional Detention Standards include:

1. Detention basin outlet capacity shall be based on the downstream channel capacities (existing or Master Planned) with consideration given to inflows occurring below the detention basin.
2. All detention basins are required to properly function under all debris and sedimentation conditions. A minimum additional capacity for storage of sediments for three years is recommended.
3. In-channel detention basins typically will be required to safely pass the Probably Maximum Flood (PMF) discharge as a minimum. HMR 49 (1977) shall be used to calculate PMF flows.
4. Detention ponds shall be designed to include provisions for security/public safety.
5. Basins should be drained in not more than 7 days with the preferred standard drain time set at 48 hours. (Drain time is defined as the time from the end of precipitation until the basin is drained of 90 percent of design capacity.)
6. A minimum of 1 foot of freeboard is required above the emergency spillway design water surface elevation (See Figure 1301).
7. Basins shall be self-regulating (passive).
8. Dams greater than 20 feet in height or impounding more than 20 acre feet of water must be approved by the State Engineer.
9. Inflows shall be based on ultimate development conditions and Master Planned tributary area.
10. Design of all detention basins shall include emergency spillways.
11. Embankment protection shall be considered for each basin.

1302.2 LOCAL DETENTION

Since the functions of local minor and local major detention facilities are different, the development guidelines for each are described separately below:

1302.2.1 LOCAL MINOR DETENTION

Local minor detention may be required for developments in hydrologic basins of less than or equal to 20 acres in size. The need for local minor detention is based on analysis of downstream conveyance (e.g., street or storm sewer system capacity) and/or pre- and post-development hydrology.

Local Minor Detention Guidelines include:

1. Public safety should be paramount in all designs.
2. Accommodation of debris and sedimentation should be considered in all designs.

Local Minor Detention Standards include:

1. Post-development peak discharges must not exceed pre-development discharges if downstream facilities lack adequate capacity to handle the increased flow rates.
2. Basins must drain completely in less than 24 hours.
3. A minimum 1 foot of freeboard is required above the major design storm water surface elevation.

1302.2.2 LOCAL MAJOR DETENTION

Local major detention may be required for developments in hydrologic basins of greater than 20 acres and where upstream off-site flows must be intercepted and controlled to protect the development. Design of such basins should be coordinated with the Jurisdictional Entity.

Local Major Detention Guidelines include:

1. Off-channel detention basins are preferred.
2. All basins are required to properly function under debris and sedimentation conditions. Adequate access must be provided for the necessary equipment to periodically remove accumulated sediment and debris.
3. Multi-use (e.g., recreation) can be considered for all detention basins.
4. Below-grade detention basins are preferred to above-grade detention basins.

Local Major Detention Standards include:

1. Detention basin outlet capacity will be based on downstream conveyance system capacities with consideration given to inflows below the detention basin, or pre- and post-development hydrology.
2. Detention basins shall be drained in not more than 3 days with the preferred drain time set at 24 hours.

3. A minimum of 1 foot of freeboard will be required above emergency spillway design water surface elevation or as required by the State Engineer.
4. Detention basins shall be self regulating (passive).
5. Emergency outlets will be incorporated on all detention basins.

1302.2.3 LOCAL MINOR RETENTION

Local minor retention may be required for containing stormwater in the event downstream conveyance is unavailable or detention is infeasible. The purpose of a retention basin is to temporarily store runoff and allow for infiltration into the underlying soils. Local minor retention basins are defined as serving hydrologic basins smaller than or equal to 20 acres. Local major retention basins are not recommended. More design criteria are available in the Structural Controls Design Manual and Low Impact Development Handbook, developed by the Truckee Meadows Regional Storm Water Quality Management Program.

Local Minor Retention Guidelines include:

1. Public Safety should be paramount in all designs.
2. Flat terrain is the preferred location for a retention basin.
3. The basin shall be below-ground and have dimensions that facilitate infiltration.
4. Soil permeability shall be determined in the least permeable soil layer.
5. Soil shall have permeability equal to or greater than 1 inch per hour.
6. Soil permeability should be determined using percolation or “Perk” tests used to design septic systems or equivalent procedures.
7. The depth of bedrock and/or groundwater level shall be a minimum of 5 feet below the design bottom elevation of the basin at all times.
8. The basin shall be designed to allow bypassing of the peak runoff in the event the facility clogs. This bypass can be provided by overland relief.
9. Accommodation of debris and sedimentation should be considered in the design.
10. The basin shall be designed to contain the volume of runoff generated by the design peak discharge with an additional volume for average sediments accumulation for three years.
11. Designs should be based on post development conditions.
12. Erosion protection shall be considered for side slopes and inlet works.
13. Adequate access must be provided for the necessary equipment to regularly remove accumulated sediment and debris.
14. Designs shall include an analysis of groundwater effects of the completed and operating basin on the surrounding groundwater levels, since change in the groundwater could adversely impact neighboring facilities including basements, septic systems and existing wells.
15. Permanent structures such as buildings and roads and other surcharge loads shall be located a safe distance away from the basin.

1303 HYDROLOGIC DESIGN METHODS AND CRITERIA

The hydrologic design of detention facilities is based on the type of facility (regional vs. local) and the method used to estimate the runoff (HEC-1/HEC-HMS vs. Rational Method). If HEC-1//HEC-HMS is used, a full hydrograph is available for traditional storage routing. If the Rational Method is used, a simplified triangular procedure has been developed for use in the Washoe County area.

1303.1 INFLOW HYDROGRAPH

Determining the required detention storage is based on volume calculations derived from the inflow hydrograph and the maximum outlet flow. The inflow hydrograph shall be based on ultimate development conditions.

1303.1.1 HEC-1/HEC-HMS METHOD

The hydrograph for local and regional facilities may be calculated using HEC-1/HEC-HMS (Section 700). HEC-1/HEC-HMS can calculate a hydrograph for any location of interest in the hydrologic basin. The HEC-1/HEC-HMS data input file must be structured so that the proposed detention basin site is a hydrograph routing or hydrograph combining point. For specific model input format, see the HEC-1/HEC-HMS User's Manual.

1303.1.2 RATIONAL FORMULA METHOD

For the design of local minor detention facilities in hydrographic areas of less than 10 acres, a simple, "triangular" hydrograph can be developed using the Rational Formula Method. The application of the Rational Formula Method is described in Section 704.

The Rational Method is traditionally used solely for peak runoff estimation, but a hydrograph can be constructed on the basis of the following assumptions:

- a) Peak flow occurs at the t_c ;
- b) Flow increases linearly from $q = 0$ to $q = Q_{\text{peak}}$ for $t = 0$ to $t = t_c$;
- c) Flow decreases linearly from $q = Q_{\text{peak}}$ to $q = 0$ for $t = t_c$ to $t = 2t_c$.

The resulting hydrograph is triangular in shape and has a volume given by

$$V = 60 (t_c * Q_{\text{peak}}) \tag{1301}$$

Where, V = Volume in ft^3 ;
 t_c = Time of concentration in minutes;
 Q_{peak} = Peak flow rate in cfs.

Nevada Department of Transportation does not accept detention basin sizing based on the Rational Method. A full hydrograph method is required.

1303.2 DETENTION BASIN DESIGN OUTFLOW LIMITATIONS

The controlled outlet capacity has direct influence on the size of the basin. The outflow limitation can be based on either the existing undeveloped peak flow from the hydrologic basin or on limitations in the capacity of the downstream conveyance system (based on a hydrologic analysis of local conditions).

1303.2.1 REGIONAL FACILITIES

The allowable release rate for regional facilities in the Master Plan is based on the non-damaging capacity of the downstream conveyance system or on the conveyance capacity of the system as improved by the detention project. The design maximum outlet capacity of a regional facility must be coordinated with the Jurisdictional Entity.

1303.2.2 LOCAL FACILITIES

The outflow limitation for local facilities is stated in Section 303.7. Existing flow conditions will be calculated based on development conditions that exist prior to construction of the project. The allowable outlet rate is equal to the existing peak runoff rate.

1303.3 HYDROLOGIC CALCULATION METHODS

After the inflow hydrograph has been calculated (Section 1303.1) and the outflow limits (Section 1303.2) have been established, the storage volume requirement can be estimated. Separate methods for calculating required storage are used depending on the method used to estimate the inflow hydrograph.

1303.3.1 HEC-1/HEC-HMS METHOD

In order to calculate the required storage volume at a particular detention basin site, the following information is necessary:

- a) Inflow hydrograph
- b) Outlet capacity limitation
- c) Proposed outlet discharge versus elevation data for the proposed basin site
- d) Proposal storage versus elevation data for the proposed basin site
- e) Proposed drain time for the proposed basin site

The HEC-1 or HEC-HMS computer program can be used to determine the required storage volume and outflow limitation based on a reservoir routing procedure. Initial estimates of outlet size are made and the program is run. The output is reviewed and changes are made to the outlet configuration as needed until the desired degree of flood peak attenuation and acceptable drain time is achieved. This method is shown in the example in Section 1307.1.

1303.3.2 RATIONAL METHOD

After the inflow hydrograph (Section 1303.1) and the outflow limitation (Section 1303.2) have been determined, the required storage volume can be calculated. The estimated hydrograph is plotted at a suitable scale. The maximum outflow rate is plotted on the receding limb of the hydrograph. A straight line is constructed from the origin to the outlet limit on the receding limb. The area above this line is the required storage volume. The estimation of required storage volume is shown in the example in Section 1307.2.

1304 OUTLET STRUCTURES

This section describes the methods to be used to size outlet structures for detention facilities. Although the methods presented are recommended for the hydraulic structures described, alternative hydraulic techniques may be more appropriate depending upon the configuration of the outlet structure.

1304.1 LOW FLOW OUTLETS

The low flow outlet (principal spillway) is sized to control discharge from a basin as set forth in Section 1303.2.

In traditional detention basins, outlet control is usually provided by a culvert or large (> 18" diameter) pipe conduit. The types of low flow control typically used for parking lot detention are small under-sidewalk weirs or pipes.

1304.1.1 MINIMUM CONDUIT SIZE

To reduce the potential for outlet clogging by debris, minimum conduit sizes have been set for the Jurisdictional Entities. The minimum conduit size for use in detention facilities is 12-inch diameter or equivalent. Orifice plates may be utilized to restrict flows from these minimum pipe sizes.

1304.1.2 FLOW CALCULATIONS

1304.1.2.1 Pipe Outlets

The capacity of outlets shall be calculated using nomographs in Section 1100.

1304.1.2.2 Orifices

The capacity of a small closed conduit (Section 1100 nomographs are not applicable) is estimated assuming inlet control using the orifice equation shown below:

$$Q = CA (2gh)^{1/2} \tag{1302}$$

where, Q = discharge in cfs;
 A = cross-sectional area of conduit in ft²;
 g = gravitational constant (32.2 ft/sec²);
 h = head, in ft, above centerline of orifice opening;
 C = orifice coefficient (0.65).

The orifice coefficient to be used in all calculations is 0.65, unless deviation from this value is approved by the Jurisdictional Entity.

1304.1.2.3 Weirs

There are two main types of weirs used in detention basin outlet structures, sharp-crested and broad-crested. Sharp-crested weirs have a sharp upstream edge so formed that water springs clear of the crest. A broad-crested weir has a horizontal or nearly horizontal crest sufficiently long in the direction of flow so that the overflowing sheet of water, or nappe, will be supported and hydrostatic pressures will be fully developed for at least a short distance. The V-notch weir is a

type of sharp-crested weir that is sometimes used in outlet structures. The V-notch weir has a triangular opening.

The capacity of a weir can be estimated using the following equations (Brater and King, 1976):

1. Horizontal crested weirs

For horizontal crested weirs (both broad-crested and sharp-crested)

$$Q = C L H^{3/2} \tag{1303}$$

Where

Q = Flow (cubic feet per second)

C = weir coefficient

= 3.3 for a sharp-crested weir

= 2.65 for a broad-crested weir

L = Effective horizontal length of weir in feet

H = Head (feet)

True sharp-crested weirs are seldom encountered in hydraulic structures and are normally used for flow measurements, but weirs can sometimes be treated as sharp-crested weirs under the appropriate conditions. When the head is greater than or equal to two times the breadth of the weir crest, the weir may be considered as a sharp-crested weir. When the head is less than or equal to one-half the breadth of the weir crest, the weir is considered as a broad-crested weir. This relationship is summarized below:

$$C = 2.63, \text{ when } H \geq 2 (W)$$

$$C = 3.3, \text{ when } H \leq 0.5 (W)$$

where, W = breadth of weir crest in feet.

When $0.5 (W) \leq H \leq 2 (W)$, then a straight line approximation may be used to obtain a value of C.

End contraction occurs when the horizontal weir opening does not extend the full width of the approach channel. Water flowing near the walls must move toward the center of the channel to pass over the weir, thus causing a contraction of the flow. The flow width continues to contract as it passes over the crest. Below the crest, the flow has a width less than the crest width. Flow will also be contracted at bends in the weir (i.e. 4-sided drop inlet).

The effective length of a weir with contracted flow is:

$$L_e = L - 0.1 NH \tag{1304}$$

where, L_e = effective horizontal length of weir (feet);

L = measured length of weir crest (feet);

N = number of end contractions + number of bends;

H = head (feet).

For instance, if the outlet from the detention basin was a 3-sided weir with two 90° bends and flow contractions at both ends of the weir, N would be:

$$N = 2 + 2 = 4$$

The head is measured from the weir crest to the water surface elevation at a distance 2.5 (H) upstream from the weir, to be beyond the drop in the water surface (surface contraction) near the weir.

2. V-Notch weirs

For V-notched weirs (Brater, 1976),

$$Q = C_1 \tan (\theta/2) H^{5/2} \quad (1305)$$

where, Q = flow in cfs

C₁ = weir coefficient

θ = angle of V-notch (degrees)

H = head (feet)

Figure 1302 provides values of C₁ for a V-notch weir for values of head from 0.2 feet to 1.0 feet. For values of head greater than 0.8 feet, assume that C₁ is 2.5 (Brater, 1976).

The head is measured from the notch elevation to the water surface elevation at a distance 2.5 (H) upstream from the weir.

The V-notch weir is better than a rectangular sharp-crested weir for measuring low discharges since flow over a V-notch weir starts at a point and the discharge and width of flow increases as a function of depth.

1304.2 SPILLWAYS

Since storm flows may enter a detention facility in excess of the maximum design flow of the outlet works, a safe method of passing these flows must be provided. All detention facilities must have the ability to pass flows in excess of the major design storm without endangering the structural integrity of the facility or diverting flows from their historic drainage pattern.

A detention basin may have more than one spillway, or in the case of local facilities, the complete structure may be designed to act as an overflow section. If a basin has only one spillway, it must be able to pass both the design flow and a larger flow to provide a margin of safety. These larger flows are discussed in Section 1304.2.1. If the geometry of the basin site does not allow for a single spillway to serve these two flows, two spillways may be provided. The principal spillway will be designed to handle the major design storm flow. If flow is greater than the major design storm flow, the emergency spillway would allow these greater flows to be passed safely. For minor local detention structures, the structure may be designed to be safely overtopped and the structure itself is the emergency spillway.

1304.2.1 SIZING REQUIREMENTS

All detention basins in Washoe County shall have emergency spillways which safely pass the following peak flow rates:

1. Regional Facilities: The spillway will be required to pass, as a minimum, half the runoff from a PMF event if approval of the State Engineer's Office is not required (1306.1).
2. Local Major Facilities: The spillway will be required to pass, as a minimum, a hydrograph developed by using twice the adjusted point precipitation of the major storm if approval of the State Engineer's Office is not required (1306.1).

3. Local Minor Facilities: Emergency spillways for local minor facilities shall be designed to pass the major storm if approval of the State Engineer's Office is not required (1306.1).

Consideration shall be given to failure of the detention structure, outlet works and downstream facilities due to events in excess of the major storm.

1304.2.2 FLOW CALCULATIONS

The equation for flow over a spillway is the same as that for flow over a horizontal crested weir given in Section 1304.1.2 (Equation 1303). The discharge coefficient, C, for broad or ogee-crested weirs is normally used in design. A graph for coefficient estimation for ogee-crested weirs is provided as Figure 1303.

1304.2.3 SPILLWAY DESIGN

The spillway should be designed so the water is always in positive contact with the spillway invert. The profile of the spillway can be designed according to the trajectory transition section discussed in Section 1202.2.6 and shown in Figure 1214.

1305 DEBRIS AND SEDIMENTATION

The performance and reliability of detention facilities can be reduced by natural and man-made debris. Naturally occurring sedimentation can over a period of time, reduce the storage capacity of a detention basin and thereby reduce the degree of flood protection provided. The obstruction of low flow conduits by debris can reduce outlet capacity and cause the premature filling of the detention basin with storm water, again reducing the flood protection provided by the structure. Consequently, adequate care must be exercised in design to provide for protection of the outlet works from debris and for the control and removal of sedimentation in the basin.

1305.1 TRASH RACKS

All outlet works and low flow conduits shall be provided with a trash rack for debris control. The trash rack shall provide a maximum bar spacing not to exceed two-thirds of the outlet opening diameter or 6 inches, whichever is less. In addition, the total open area of the trash rack shall be at least four times larger than the open area of the detention pond outlet. Trash racks should be hinged at the top to permit lifting and cleaning and should slope at 3:1 to 5:1 (horizontal to vertical) to permit debris to float up and down as the water level rises and falls. Head losses through a trash rack shall be included in the outlet's hydraulic evaluation.

1305.2 SEDIMENTATION

The storage volume of a detention basin can be reduced and/or eliminated by sediment deposition. Depending on the cover and soil conditions in a watershed, detention basin filling may happen slowly over a period of many years or, in extreme cases, during one storm event.

Sedimentation effects may be reduced by the construction of debris basins (Section 1400) upstream of the detention facility or by providing additional storage capacity in the detention facility for storage of sediment. Section 1400 presents some basic information regarding debris sedimentation, control, facilities.

1305.3 SEDIMENT YIELD ESTIMATION

1305.3.1 SEDIMENT SOURCES

Sediments are derived from erosion from watersheds. The gross erosion includes upland erosion, gully erosion, and local stream bank and bed erosion. Upland erosion usually is the primary source of sediment. Other sources of gross erosion, such as mass wasting or bank erosion and gully erosion should be estimated separately by calculating the volume of sediment scoured through lateral migration of the stream and the upstream migration of headcuts. In relatively stable fluvial systems, the analysis of sediment sources and yield focus primarily on upland erosion from rainfall and snowmelt. For watersheds having defined channels, potential sediment supply from stream bank and bed erosion can be estimated using a sediment transport equation. The total sediment yield can be estimated by summing the sediment supply from upland erosion and the sediment supply from stream bank and bed erosion.

1305.3.2 METHODS FOR ESTIMATING SEDIMENT YIELD

Many approaches can be used to determine sediment yield from natural or disturbed land surfaces. One category is the “black box,” or lumped parameter model. Another category is based on regression equations, such as the Universal Soil Loss Equation (USLE). A third approach is through the use of stochastic models. Most hypotheses used in stochastic models have not been tested by field data. Knowledge in applying stochastic models to sediment yield from watersheds is still primitive.

The physical process simulation model is another type of method in which the governing processes controlling sediment yield are formulated and analyzed separately to provide model sensitivity to land management alternatives. These models are used to estimate or predict sediment yields resulting from natural or disturbed watershed lands, taking into account important physical processes such as raindrop splash, overland flow erosion, channel erosion, and movement of different sediment size fractions. However, these models are complex and require special expertise.

One important aspect of model development and operation is data requirement. Without adequate data, testing and verification, applications of models to field situations may produce misleading results. With a sound understanding of model operations and the controlling physical processes as well as sufficient quality data, models can produce realistic estimates of sediment yield from watersheds.

1305.3.3 UNIVERSAL SOIL LOSS EQUATION

The USLE is the most widely used empirical relationship for estimation of gross erosion from upland areas (Smith and Wischmeier, 1957). This equation has been used on cropland and rangeland to estimate long-term (10 years or more) average annual soil losses from sheet and rill erosion with varying degrees of success, depending on the amount of quantitative data available to estimate factor values (Wischmeier, 1973). The USLE equation is:

$$A = R K L S C P \tag{1306}$$

where, A = estimated annual soil loss in tons/acre;
 R = rainfall erosivity factor;
 K = soil erodibility factor,
 L = length factor (based on flow length before convergence of rills);

S = slope steepness factor;
 C = cover factor (based on canopy cover, roughness, vegetative mass; and
 P = support practice factor (based on practices such as terracing).

Smith and Wischmeier (1957), Meyer and Monke (1965), and Wischmeier (1973) provide detailed descriptions of this equation.

The rainfall erosivity factor R can be calculated for each storm from:

$$R = 0.01 \Sigma (916 + 331 \log I) I \quad (1307)$$

where, I = rainfall intensity in inches/hour.

The annual rainfall erosion factor in the United States decreases from a value exceeding 500 near the Gulf of Mexico to values under 100 in the northern states and in the Rockies.

Soil erodibility factor K was found by Wischmeier, et al. (1971) to be a function of percent of silt, percent of coarse sand, soil structure, permeability of soil, and percent of organic matter. Figure 1304 shows the soil erodibility nomograph.

The topographic factor (product of L and S) is defined as the ratio of soil loss from any slope and length to soil loss from a 72.6 foot plot length at a 9 percent slope, with all other conditions the same. This factor can be approximated from the field runoff length L_r in ft and surface slope S_o in ft/ft by:

$$L S = (L_r)^{0.5} (0.0076 + 0.53 S_o + 7.6 S_o^2) \quad (1308)$$

Where the runoff length is defined as the distance from the point of overland flow origin to the point where either slope decreases to the extent that deposition begins or runoff water enters a well-defined channel (Smith and Wischmeier, 1957). The effect of the runoff length on soil loss is primarily a result of increased potential of runoff accumulation due to longer slopes.

The cover factor C was defined as the ratio of soil loss from land cropped under specific conditions to corresponding loss from tilled, continuously fallow ground. Wischmeier (1972) presented a graphical method for the determination of the cover factor. This factor, ranging from approximately 0 to 1.0, is the product of the effect of canopy cover (C_I), effect of mulch or close-growing vegetation in direct contact with the soil surface (C_{II}), and tillage and residual effect of the land use (C_{III}). That is,

$$C = C_I C_{II} C_{III} \quad (1309)$$

Figures 1305, 1306, and 1307 show the graphical relations to estimate these factors.

The support practice factor P accounts for the effect of conservation practices such as contouring, strip cropping and terracing on erosion. Its values can be obtained from Table 1301. This factor has no significance for wildland areas and can be set at 1.0.

The USLE is used with a sediment delivery ratio, S_{DR} to estimate the amount of sediment delivered by channels at a point of interest downstream. This ratio takes into account the storage and deposition of sediment within a watershed, and is found to be highly dependent on the drainage area of the upstream watershed, A_i :

$$S_{DR} = 0.31 A_t^{-0.3} \quad (1310)$$

The sediment yield can, therefore, be written as:

$$Y_s = A S_{DR} \quad (1311)$$

This method was used by the U.S. Forest Service (1980) and many others, and was compared with other predictive methods by Allen (1981). Allen indicated that the sediment delivery ratio is oversimplified and unreliable. Wischmeier (1971) cautioned that large errors can occur if the R factor is used to predict soil loss on a storm basis.

1305.3.4 MODIFIED UNIVERSAL SOIL LOSS EQUATION

Williams and Berndt (1972) modified the USLE (MUSLE) by replacing the rainfall factor R with a runoff factor which is more applicable to short-term, high-intensity storm events. Sediment yield is calculated as:

$$Y_s = \alpha(VQ_p)^\beta K L S C P \quad (1312)$$

where, Y_s = sediment yield in tons for the given storm;

- Q_p = peak flow rate in cfs;
- V = storm runoff volume in acre-feet;
- $\alpha = 95$
- $\beta = 0.56$; and
- $K, L, S, C,$ and P are defined in equation (1306).

If the sediment yield from the land surface on an annual basis rather than a single storm event is desired, the MUSLE can also be utilized. This is accomplished by determining the soil loss for different events of varying return periods. Recommended return periods are 2, 10, 25, 50 and 100 years. The sediment yields are then weighted according to their incremental probability, resulting in a weighted storm average.

To compute the annual yield, the weighted storm yield is multiplied by the ratio of annual water yield to an incremental probability-weighted water yield. For the return periods recommended, the computation is:

$$A_s = \frac{V_A (0.01Y_{s100} + 0.02Y_{s50} + 0.04Y_{s25} + 0.1Y_{s10} + 0.5Y_{s2})}{0.01V_{100} + 0.02V_{50} + 0.04V_{25} + 0.1V_{10} + 0.5V_2} \quad (1313)$$

where, A_s is the annual sediment yield, V_A is the average annual water yield, and the numerical subscripts in the single storm event (Y_s) and water yield (V) refer to the return period of the storm.

1305.3.5 TOTAL SEDIMENT YIELD

Total sediment yield is the total of wash load and bed-material load. Wash load is defined as “that part of the sediment load which is composed of particles smaller than those found in appreciable quantities in the shifting portion of the stream bed” (Einstein, 1950). Einstein suggested the limiting sizes of wash load and bed-material load may be chosen as the grain diameter (D_{10}) of

which 10 percent of the bed mixture is finer. The wash load is usually carried away by the stream without much deposition. In contrast, the transport of bed-material load is controlled by the transport capacity of streams.

The USLE and MUSLE methods are generally used to estimate wash load. Wash load consists of the fine sizes of sediment such as clay, silt, and very fine sand which are typically transported as suspended sediment. Coarse sediment, such as sand, gravel, and cobbles are typically transported as bed load. The yield of coarser sediment can be estimated by a number of methods, such as the approach presented in Simons, Li & Associates (1982). The inclusion of channel transporting capacity is also important. It is most significant in steep sand-bed channels where the transporting capacity of the bed material sizes can be high.

1306 DESIGN STANDARDS AND CONSIDERATIONS

The following section describes current standards and special considerations for detention design.

1306.1 DAM SAFETY

All dams which store more than 20 acre-feet of water or have an embankment 20 feet or greater in height must obtain a permit from the Nevada State Engineer.

1306.2 GRADING REQUIREMENTS

All detention facilities will be graded to allow for complete drainage by the low flow outlet of the principal spillway. No permanent standing water will be allowed. Minimum grade is 0.5 percent.

1306.3 DEPTH LIMITS

The maximum ponding depth for parking lot detention facilities is 12 inches and shall include signage warning the general public as to the use of the parking lot for detention ponding.

1306.4 LOW FLOW AND BASIN DEWATERING

All detention basins shall include provisions for a small channel to ensure positive drainage and dewatering of the basin. The channel shall be sized to convey nuisance and perennial flows. Low flow criteria are presented in Section 800.

1306.5 EMBANKMENT PROTECTION

Embankments shall be protected from structural failure from overtopping. Overtopping can be caused by a larger than design inflow or from obstruction of the low flow outlet. Embankment protection may be provided by embankment armoring (i.e., riprap) or by a design overflow section (i.e., emergency spillway). The invert of the emergency spillway shall be set equal to or above the major design storm water surface elevation.

1306.6 MAINTENANCE REQUIREMENTS

All detention facilities will be designed to minimize required maintenance and to allow access by equipment and workers to perform maintenance. A maintenance plan that includes maintenance triggers, annual maintenance schedules and identifies the party responsible for maintenance shall be provided for all detention basins.

1306.7 LOCAL DETENTION BASIN SITING GUIDELINES

Local detention basins should be located as to minimize their impact on the site and to ensure public safety. Basins should not be located adjacent to buildings because of the potential of saturating foundation materials. Basins should also be placed to minimize detrimental impact on public facilities (e.g., roadway and sidewalk deterioration).

1307 EXAMPLE APPLICATIONS

1307.1 EXAMPLE: DETENTION POND OUTLET SIZING

Problem: Size the principal and emergency spillway for a detention pond given the following information:

Inflow hydrograph in Table 1302 (A)
 Basin Site characteristics in Table 1302 (B)
 Outflow limitation of 300 cfs (Major Storm)
 Emergency spillway design flow = 1,000 cfs

Solution:

Step 1: Size low flow conduit:

$$Q = C A (2gh)^{1/2}$$

$$300 \text{ cfs} = 0.65 A (2gh)^{1/2}$$

$$A = 21.8 \text{ ft}^2$$

$$\text{Diameter} = 5.3 \text{ ft, Use 72 in RCP}$$

Step 2: Develop depth-outflow data for low flow conduit as presented in Table 1302 (C).

Step 3: Perform storage routing using HEC-1 or HEC-HMS. The input data listing and resulting outflow summary is presented in Table 1303.

The results show that a storage volume of 31.4 acre-feet is sufficient to limit the pond outflow to less than 300 cfs (actual outflow = 302 cfs).

Step 4: Size Emergency Spillway

Assume $H = 2.0 \text{ ft}$

For a broad crested weir, $C_d = 2.65$

$$1,000 \text{ cfs} = 2.65 L (2.0)^{1.5}$$

$$L = 133 \text{ feet}$$

Use 135 feet

Step 5: The actual water surface elevation for the emergency spillway design flow is then found by repeating the storage routing procedure for the required emergency spillway design hydrograph.

1307.2 EXAMPLE: RATIONAL FORMULA DETENTION METHOD

Problem: Determine the required detention volume given the following parameters:

Peak flow from Rational Formula Method is 29 cfs.

Time of Concentration is 15.2 min.

Outflow is Limited to an Existing Flow Rate of 13 cfs.

Solution:

Step 1: Plot triangular hydrograph as described in Section 1303.1.2 (see Figure 1308).

Step 2: Plot outflow limitation of 13 cfs on falling limb of hydrograph (Point D on Figure 1308).

Step 3: Calculate area under triangle above line A-D (Figure 1308)

$$V = 14,592 \text{ ft}^3$$

References

- Brater, 1976 - Brater and King, *Handbook of Hydraulics* (McGraw Hill Book Company, 1976).
- City of North Las Vegas, *Onsite Stormwater Detention Manual* (1984).
- Simons, Li & Associates, 1982, *Engineering Analysis of Fluvial Systems*, Simons, Li & Associates, Fort Collins, Colorado.
- Smith, D.D. and W.H. Wischmeier, 1957, *Factors Affecting Sheet and Rill Erosion, Transactions*, American Geophysical Union, Vol. 38, pp. 889~896.
- USBR, 1987 - *Design of Small Dams* (US Department of the Interior, Bureau of Reclamation, Washington, DC, 1987).
- US Forest Service, 1980, *An Approach to Water Resource Evaluation of Nonpoint Silacultural Sources*, Environmental Protection Agency, Athens, Georgia, Interagency EPA-IAG-DG-0660.
- Williams, J.R. and H.D. Berndt, 1972, *Sediment Yield Computed with Universal Equation*, Journal of Hydraulics Division, ASCE, Vol. 98, No. HY12, Proc. Paper 9426, December, 1972.
- Wischmeier, W.H., 1972, *Estimating the Cover and Management Factor for Undisturbed Areas*, presented at the Sediment Yield Workshop, USDA Sedimentation Laboratory, Oxford, Mississippi.
- Wischmeier, W.H., 1973, *Upland Erosion Analysis, in Environmental Impact on Rivers*, H.W. Shen, ed., Colorado State University, Fort Collins, Colorado.
- Wischmeier, W.H., C.B. Johnson and B.V. Cross, 1971, *Soil-Erodibility Nomograph for Farmland and Construction Sites*, Journal of Soil and Water Conservation, Vol. 26, No. 5, pp. 189~193.

Conservation Practice Factor P for Contouring, Strip Cropping and Terracing

Land Slope (%)	Farming on Contour	Contour Strip Crop	Terracing	
			(a)	(b)
2-7	0.50	0.25	0.50	0.10
8-12	0.60	0.30	0.60	0.12
13-18	0.80	0.40	0.80	0.16
19-24	0.90	0.45	0.90	0.18

- a) For erosion-control planning on farmland
- b) For prediction of contribution to off-field sediment load

VERSION: April 30, 2009

WTC ENGINEERING, INC.

REFERENCE:

Wischmeier (1972)

TABLE
1301

Inflow Hydrograph and Basin Characteristics for Example in Section 1307.1

(A) INFLOW HYDROGRAPH

<u>TIME (MINUTES)</u>	<u>RUNOFF (CFS)</u>	<u>TIME (MINUTES)</u>	<u>RUNOFF (CFS)</u>
0	0	130	442
10	21	140	394
20	38	150	346
30	72	160	300
40	105	170	233
50	171	180	163
60	247	190	102
70	336	200	73
80	411	210	57
90	480	220	43
100	499	230	30
110	504	240	24
120	480	250	0

(B) BASIN CHARACTERISTICS

<u>ELEVATION (feet)</u>	<u>SURFACE AREA (acres)</u>
103	0
104	0.34
105	1.54
106	3.38
107	5.26
108	5.86
110	6.46
112	8.26

(C) 72" RCP DISCHARGE RATING

<u>DEPTH</u>	<u>DISCHARGE</u>
0	0
1	20
2	40
3	70
4	110
5	160
7	270
9	350

VERSION: April 30, 2009

REFERENCE:

TABLE
1302

WTC ENGINEERING, INC.

HEC-1 Run for Example in Section 1307.1

HEC-1 INPUT

LINE	ID	1	2	3	4	5	6	7	8	9	10
1	ID	SECTION 1307.1	EXAMPLE:	DETENTION	POND	OUTLET	SIZING				
2	IT	10	0	0	300						
3	IO	2	0	0							
4	QI	0	21	38	72	105	171	247	336	411	480
5	QI	499	504	480	442	394	346	300	233	163	102
6	QI	73	57	43	30	24	0				
7	KK	A ROUTED DISCHARGE FROM DETENTION POND									
8	RS	1	STO	0							
9	SA	0	.34	1.54	3.38	5.26	5.86	6.46	8.26		
10	SE	103	104	105	106	107	108	110	112		
11	SQ	0	20	40	70	110	160	270	350		
12	ZZ										

RUNOFF SUMMARY
 FLOW IN CUBIC FEET PER SECOND
 TIME IN HOURS, AREA IN SQUARE MILES

OPERATION	STATION	PEAK FLOW	TIME OF PEAK
HYDROGRAPH AT	A	504.	1.83
ROUTED TO	A	302.	2.67
PEAK STORAGE = 31 AF., PEAK STORAGE = 110.79			

VERSION: April 30, 2009

REFERENCE:

TABLE
1303

WTC ENGINEERING, INC.

Typical Basin Geometry

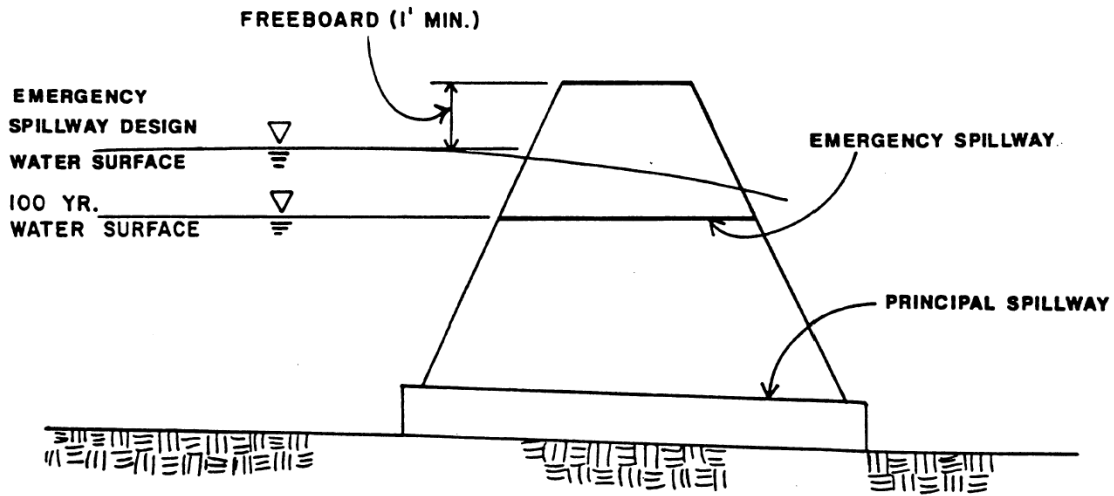

NOTES:

- 1) For local minor detention facilities, the required one-foot freeboard shall be above the 100-year water surface elevation.

VERSION: April 30, 2009

REFERENCE:

FIGURE
1301

WTC ENGINEERING, INC.

V-Notch Weir Coefficients

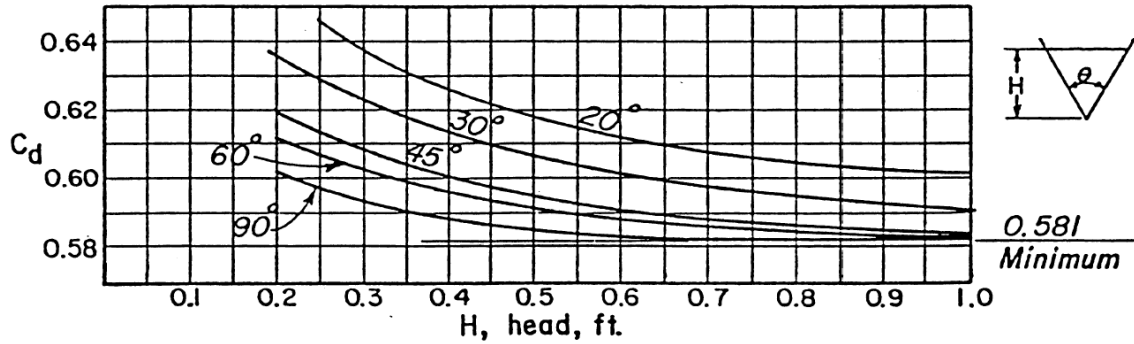

$C_1 = C_d \times (8/15) \times (2g)^{0.5}$, where, g is the acceleration of gravity.

VERSION: April 30, 2009

REFERENCE:
City of North Las Vegas, 1984, Onsite Stormwater Detention Manual

FIGURE
1302

WTC ENGINEERING, INC.

Ogee-Crested Weir Coefficients

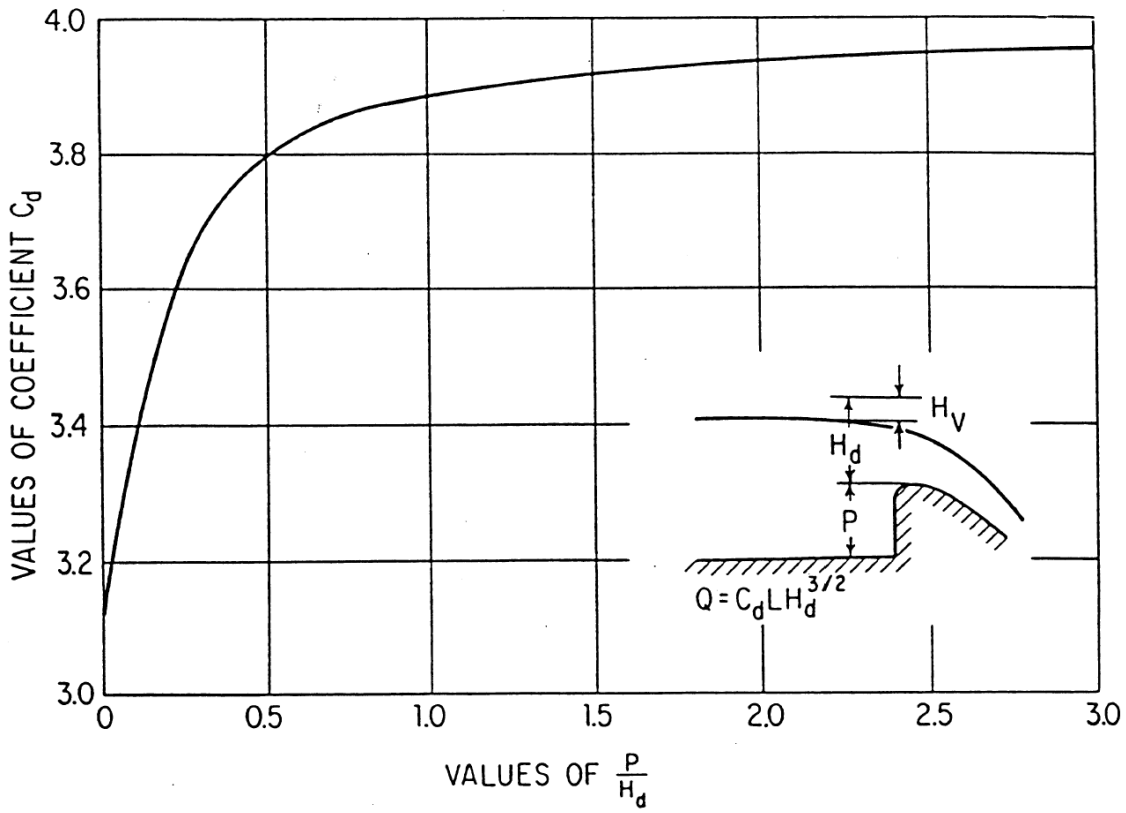

VERSION: April 30, 2009

REFERENCE:

USBR, 1987, "Design of Small Dams"

FIGURE
1303

WTC ENGINEERING, INC.

Soil Erodibility Nomograph
 Used to Determine Factor K (Tons/Acre) for Specific Topsoils or Subsoil Horizons

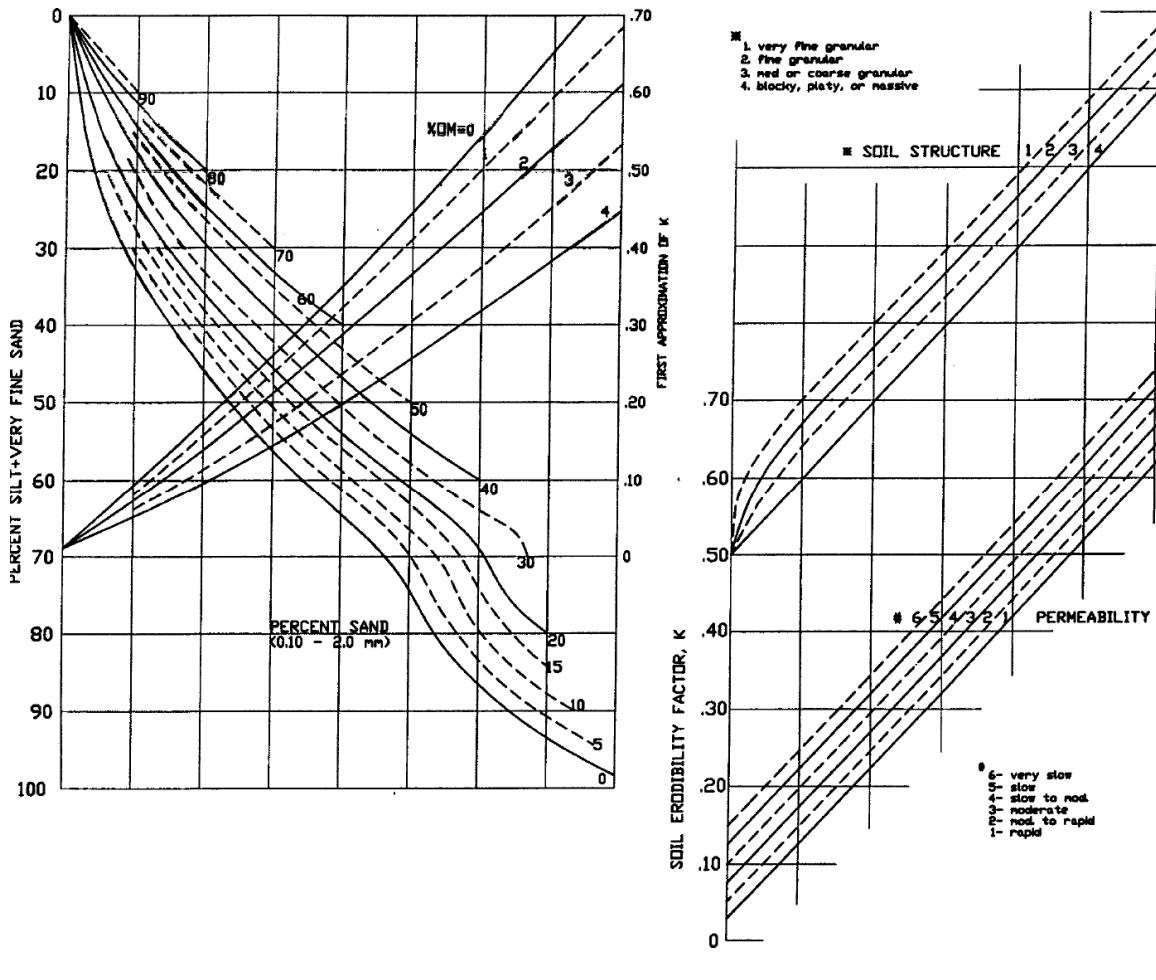

VERSION: April 30, 2009

REFERENCE:

Wischmeier, et al., 1971

FIGURE
1304

WTC ENGINEERING, INC.

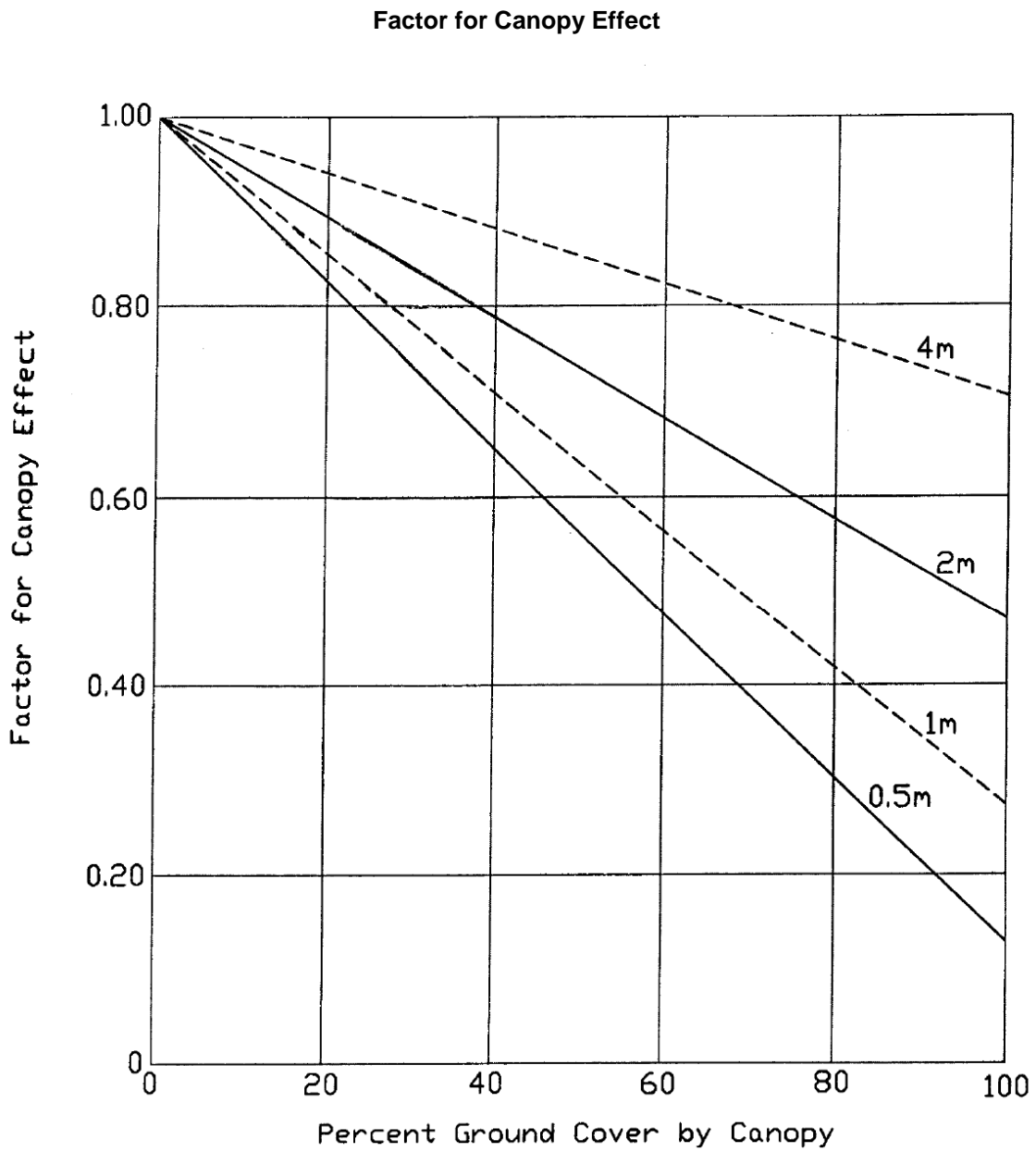

VERSION: April 30, 2009

REFERENCE:

Wischmeier, et al., 1971

FIGURE
1305

WTC ENGINEERING, INC.

Effect of Plant Residues or Close-Growing Stems at the Soil Surface

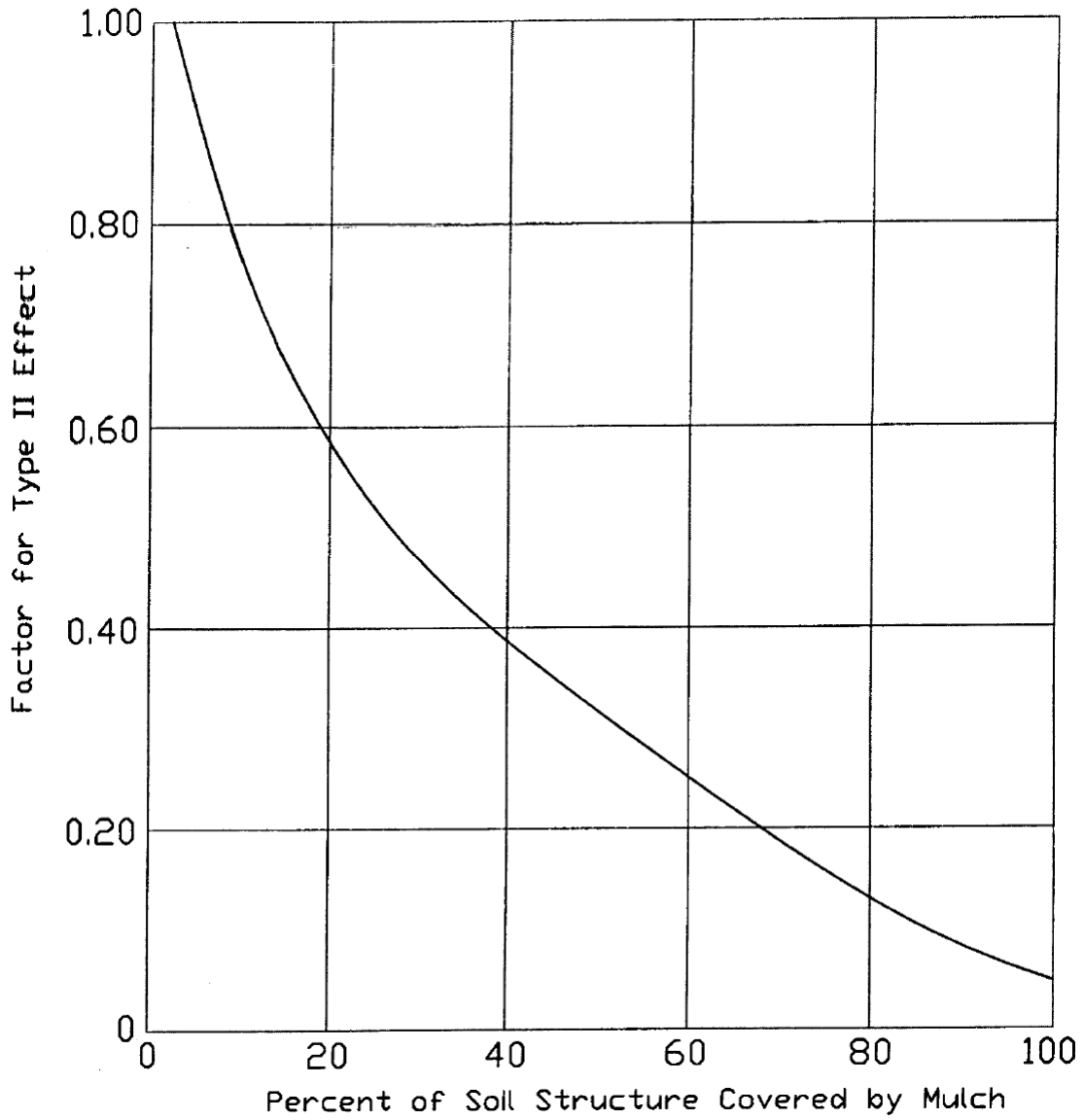

VERSION: April 30, 2009

REFERENCE:

Wischmeier, 1972

FIGURE
1306

WTC ENGINEERING, INC.

Type III Effects on Undisturbed Land Areas

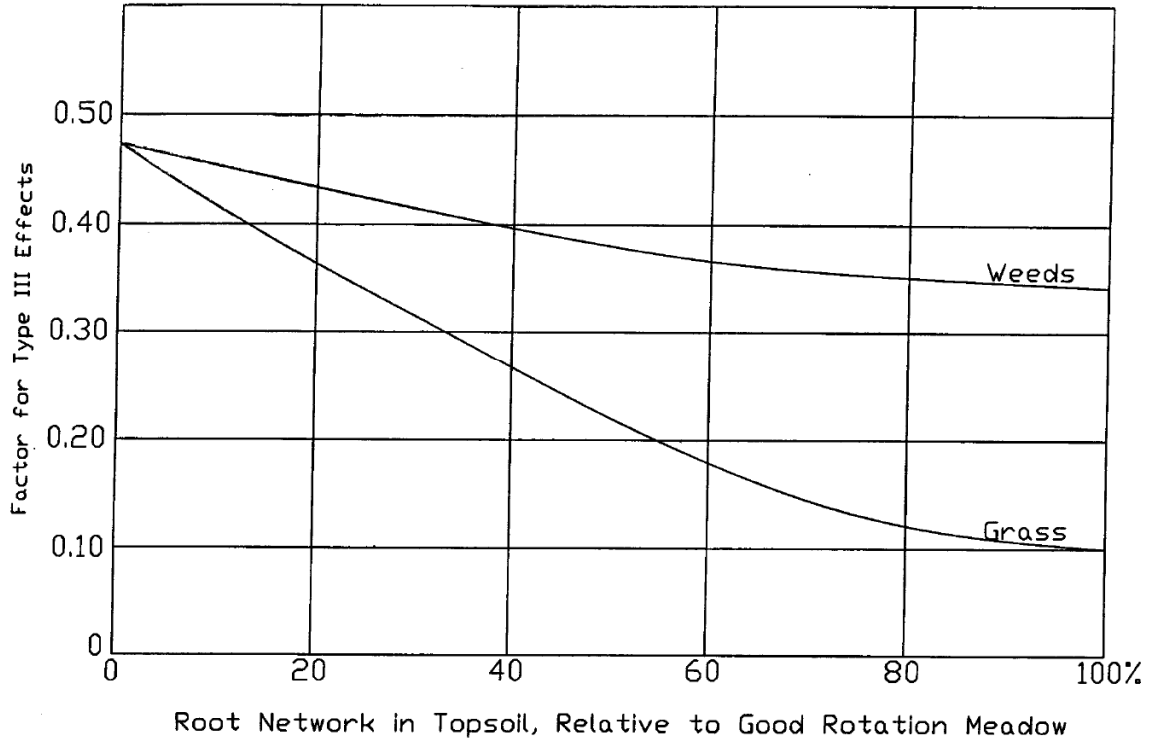

VERSION: April 30, 2009

REFERENCE:

Wischmeier, 1972

FIGURE
1307

WTC ENGINEERING, INC.

Hydrograph for Example in Section 1307.2

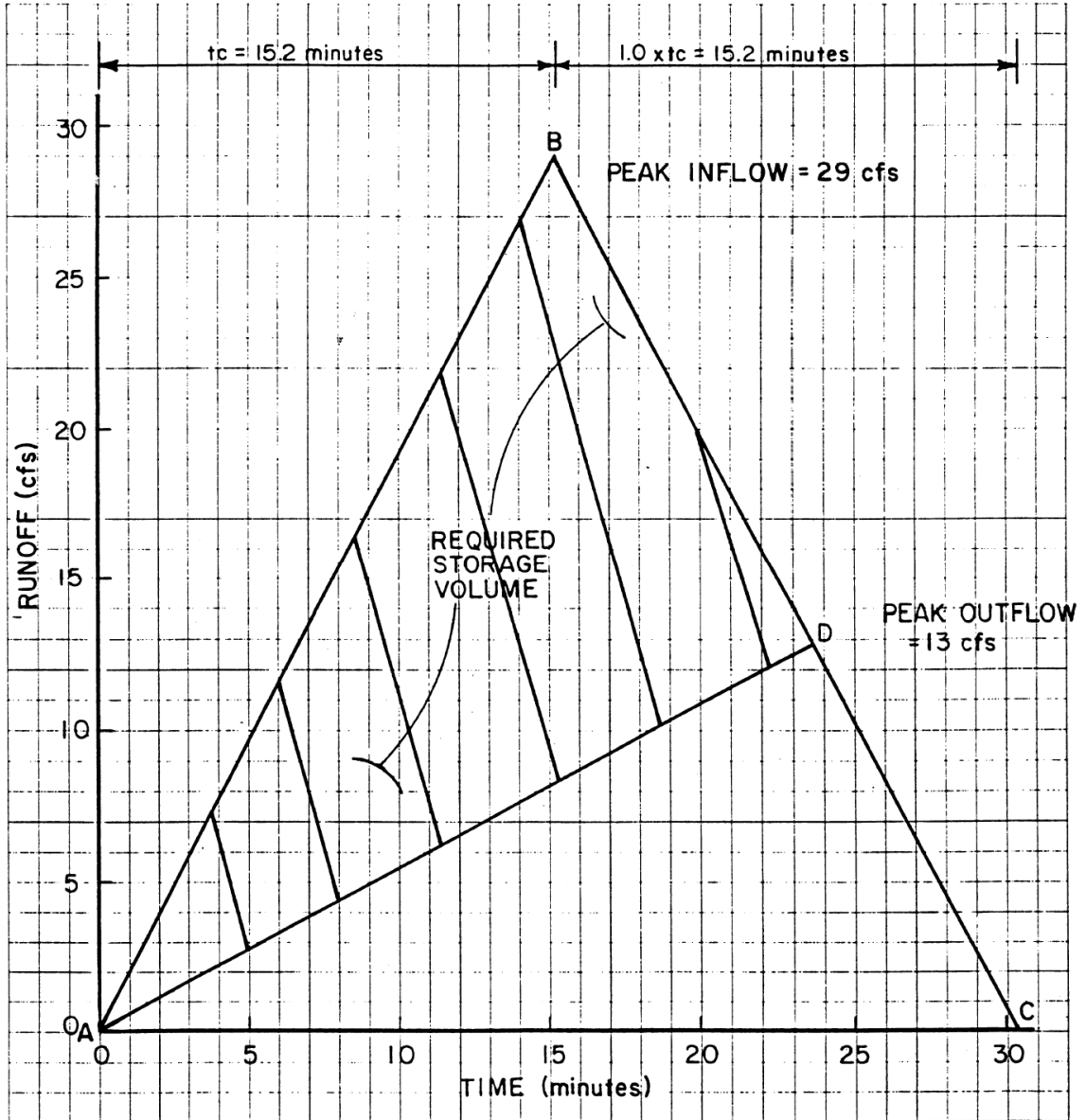

VERSION: April 30, 2009

REFERENCE:

FIGURE
1308

WTC ENGINEERING, INC.

SECTION 1400 - EROSION AND SEDIMENTATION

TABLE OF CONTENTS

	<u>Page</u>
1401 DEBRIS CONTROL STRUCTURES AND BASINS	1401
1401.1 INTRODUCTION	1401
1401.2 DEBRIS DEFLECTORS	1401
1401.3 DEBRIS RACKS	1401
1401.4 DEBRIS RISERS	1402
1401.5 DEBRIS CRIBS	1402
1401.6 DEBRIS DAMS AND BASINS	1402
1401.7 SIZING OF CONTROL STRUCTURES AND BASINS	1402
1401.8 SITING OF CONTROL STRUCTURES AND BASINS	1403

LIST OF TABLES

1401 DEBRIS STRUCTURE PERFORMANCE

LIST OF FIGURES

1401 TYPICAL DEBRIS CRIB

SECTION 1400

EROSION AND SEDIMENTATION

1401 DEBRIS CONTROL STRUCTURES AND BASINS

1401.1 INTRODUCTION

Debris transported by storm water can cause severe problems with flood control structures and other public facilities. Debris-related problems include: clogging of channels and culverts, filling of detention ponds, and burial of or physical damage to roadways and other property. Consequently, the need for debris control is an essential consideration in the design of hydraulic structures, particularly culverts and detention basin outlets.

In order to select an appropriate debris-control measure, the debris within a particular basin should be classified. A classification used by the U.S. Department of Transportation (USDOT, 1971) follows:

1. Light floating debris - small limbs or sticks, orchard prunings, tules and refuse
2. Medium floating debris - limbs or large sticks
3. Heavy floating debris - logs or trees
4. Flowing debris - heterogeneous fluid mass or clay, silt, sand, gravel, rock, refuse, or sticks
5. Fine detritus - fairly uniform bedload of silt, sand, gravel more or less devoid of floating debris, tending to deposit upon diminution of velocity
6. Coarse detritus - coarse gravel or rock fragments carried as channel bedload at flood stage
7. Boulders

Debris can be controlled by three methods: 1) interception near the debris source or above a critical hydraulic structure downstream of the source, 2) deflecting the debris for detention near (usually above) a culvert or inlet, or 3) passing the debris through the channel or inlet structure. Commonly used structures for controlling various types of debris are listed in Table 1401 and described in the following sections.

1401.2 DEBRIS DEFLECTORS

Debris deflectors are used to divert medium and heavy floating debris and large rocks from the culverts (or other inlets) for accumulation in a storage area and subsequent removal after the flood subsides. The storage area must be adequate to retain the anticipated type and quantity of debris during any one storm or between clean-outs.

1401.3 DEBRIS RACKS

Debris racks provide barriers across stream channels to stop debris that is too large to pass through downstream channels or culverts. Debris racks vary greatly in size and in construction material. Height of racks should allow some freeboard above the expected depth of flow in the upstream channel for the design flood. Racks should not be placed in the plane of the culvert entrance, since

they induce plugging when thus positioned. Access to the rack is necessary for maintenance. The rack should be placed well upstream from the culvert or improved channel inlet in those situations where a well-defined upstream channel exists. However, they should not be placed so far upstream that debris enters the channel between the rack and the inlet.

1401.4 DEBRIS RISERS

Debris risers generally consist of a vertical culvert pipe and are usually suitable for installations of less than 54-inch diameter. Risers are normally used with detention ponds or debris basins or where a considerable height of embankment is available above a culvert crossing. The riser is particularly effective where debris consists of flowing masses of clay, silt, sand, sticks, or medium floating debris without boulders. Risers are seldom structurally stable under high-velocity flow conditions because of their vulnerability to damage by impact.

1401.5 DEBRIS CRIBS

Debris cribs are particularly adapted to small-size culverts where a sharp change in stream grade or constriction of the channel causes deposition of detritus at the culvert inlet. The crib is usually placed directly over the culvert inlet and in "log cabin" fashion.

Figure 1401 shows the general dimensional details of a typical debris crib. Spacing between bars should be about 6 inches. A crib may be open or covered with horizontal top members spaced equal to the crib members. Debris can almost envelop a crib without completely blocking the flow and plugging the culvert. When an open crib is used as a riser and an accumulation of detritus is expected, provision can be made for increasing the height.

1401.6 DEBRIS DAMS AND BASINS

On channels carrying heavy sediment and debris loads, it is often economically impracticable to provide culverts large enough to carry surges of debris. If the height of an embankment and storage area are not sufficient for a riser or crib, a debris dam and/or basin placed some distance upstream from the culvert may be feasible. These are sometimes used to trap heavy boulders or coarse gravel that would clog culverts.

Detention basins located in the mountain canyon areas can accumulate large deposits of rocky debris, either over the course of several years or after each extremely large load event. Design of detention ponds (Section 1300) in these areas must include provisions for debris (and suspended sediment) deposits and control of floating debris using debris racks and/or risers.

Much of the rock debris will deposit in the upper reaches of detention ponds where high-velocity flood waters first encounter slack, ponded water. If regularly maintained and cleaned of these deposits, detention ponds can effectively serve multiple purposes of attenuation of flood peaks and entrapment of sediment and debris (see Section 1300 for further discussion of detention pond design).

1401.7 SIZING OF CONTROL STRUCTURES AND BASINS

The spacing of bars on trash racks, debris racks, debris deflectors, debris risers and debris cribs is based on the size of the structure to be protected and the anticipated size and gradation of the debris. To minimize the potential for clogging, in no case shall the barrier members be spaced more than two-thirds of the conduit diameter.

The size of debris basins is most dependent on the physical properties of the watershed and the intensity of flood events. Specific sedimentation data have not been developed for the Washoe County area, and designs must be based on site specific data from other areas. The U.S. Department of Agriculture reports sedimentation rates for reservoirs nationwide in a report "Sedimentation Deposition in U.S. Reservoirs: Summary of Data Reported Through 1975" (USDA, 1976). The average annual sedimentation rates reported vary over five orders of magnitude. For this reason, the use of data from other areas is limited.

The major threat to debris basins is from a single rare flood event. The Los Angeles Department of Public Works published curves for debris production per storm event for the Los Angeles area (LADPW, 1989). These rates vary from approximately 250,000 yd³/square mile to 4200 yd³/square mile. Again the soil types and storm patterns vary considerably between Los Angeles and Washoe County, but the data developed for Los Angeles does illustrate the problem.

1401.8 SITING OF CONTROL STRUCTURES AND BASINS

Debris control structures which protect other hydraulic structures (e.g. culverts, bridges, channels) are placed based on structure cost, debris production potential and the importance of the structure. Minor culverts whose failure would have a limited impact on downstream structures would require less debris protection than a major lined channel. Generally speaking, debris control structures should be placed as close as possible to the debris source.

1402 CONTROL OF EROSION FROM CONSTRUCTION ACTIVITIES AND STORM WATER QUALITY IMPROVEMENT

The Jurisdictional Entities use the Truckee Meadows Construction Site Best Management Practices Handbook (BMPH) and the Truckee Meadows Structural Controls Design Manual for control of erosion and sedimentation for construction activities and for storm water quality management. This BMPH and the Structural Controls Design Manual are hereby adopted and made a part of this Manual by reference.

References

LADPW, 1989 - *Hydrology Manual* (Los Angeles County Department of Public Works, Alhambra, California, December 1971, revised March 1989).

USDA, 1976 - *Sedimentation Deposition in US Reservoirs, Summary of Data Reported through 1975* (US Department of Agriculture, Washington, DC, 1976).

USDOT, 1971 - *Debris Control Structures, EPD-86-106, HEC 9* (US Department of Transportation, Federal Highway Administration, Washington, DC, 1971).

DEBRIS STRUCTURE PERFORMANCE

Debris Classification	Type of Structure				
	Debris Deflector	Debris Rack	Debris Riser	Debris Crib	Debris Basin and Dam
Light Floating Debris		X		X	
Medium Floating Debris	X	X			
Heavy Floating Debris	X				
Flowing Debris			X		X
Fine Detritus			X		X
Coarse Detritus			X	X	X
Boulders	X				

VERSION: April 30, 2009

WTC ENGINEERING, INC.

REFERENCE:

USDOT, FHWA, HEC No. 9, 1971

TABLE
1401

TYPICAL DEBRIS CRIB

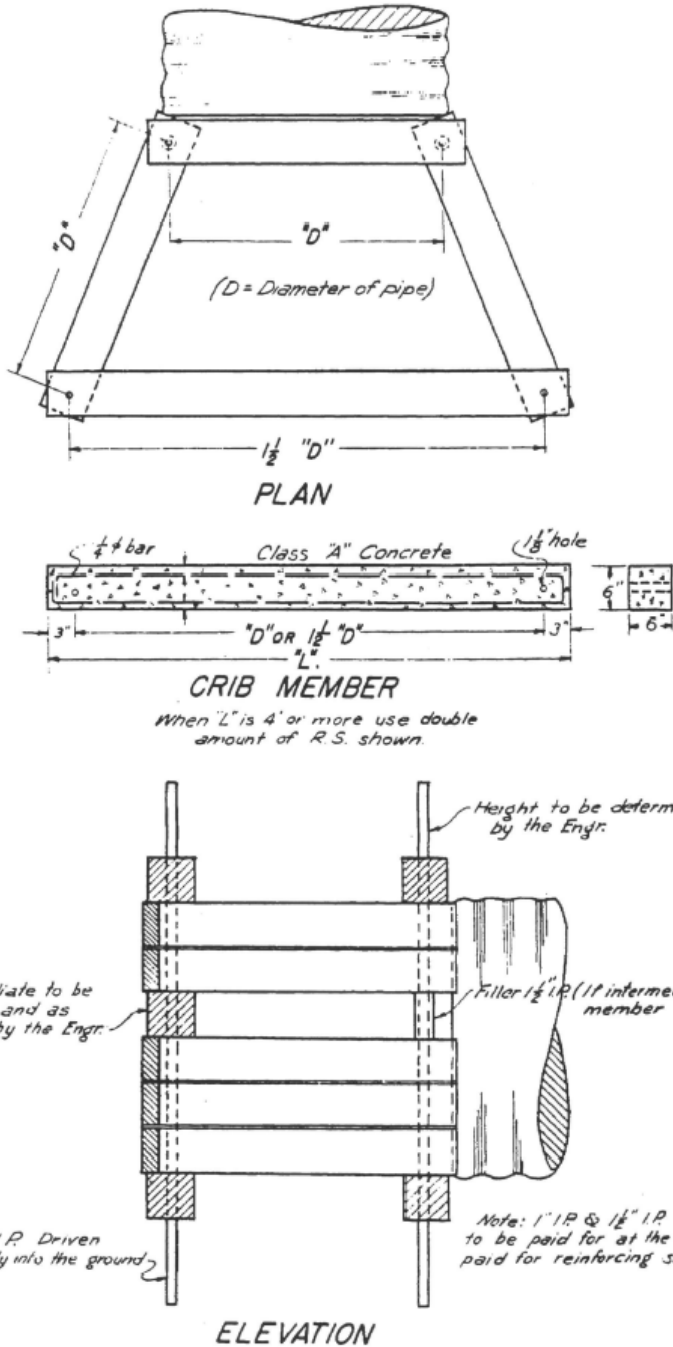

VERSION: April 30, 2009

WTC ENGINEERING, INC.

REFERENCE:
USDOT, FHWA, HEC NO. 9, 1971

FIGURE
1401

SECTION 1500 - STANDARD FORMS

STANDARD FORM 1	DRAINAGE REPORT SUBMITTAL CHECKLIST
STANDARD FORM 2	TIME OF CONCENTRATION
STANDARD FORM 3	STORM SEWER HYDRAULIC CALCULATIONS
STANDARD FORM 4	CULVERT DESIGN

DRAINAGE REPORT SUBMITTAL CHECKLIST

PREPARED BY:		DATE:	
The drainage report for the development noted below has been received and found to lack the information needed. This information must be submitted before the report will be accepted for review. Please provide the required information.			
DEVELOPMENT:			
LOCATION:			
DATE SUBMITTED:			
SUBMITTED BY:	FIRM		
	CONTACT		
	PHONE		
<input type="checkbox"/> Conceptual Report		<input type="checkbox"/> Technical Report	<input type="checkbox"/> Flood Plain Study
CHECKLIST			
ITEM	DESCRIPTION	RECEIVED OR NOT APPLICABLE	TO BE SUBMITTED
1	Typed, Bound Report with Transmittal Letter		
2	Professional Engineer's Certificate		
3	General Location and Description		
	a. Location Map		
	b. Existing Site Description		
	c. Proposed Project Description		
4	Discussion of Previous Studies		
5	Hydrologic and Hydraulic Analysis		
	a. Discussion of Hydrologic Criteria/Methods		
	b. Discussion of Hydraulic Criteria/Methods		
	c. Calculations (in Appendix)		
6	Historic Drainage System		
	a. Discussion of Minor and Major Storm Flows and Patterns		
	b. Discussion of Existing Structures		
	c. Basin Map		
7	Proposed Drainage System		
	a. Drainage Map		
	b. Discussion of Minor and Major Storm Flows and Patterns		
	c. Description of Proposed Improvements		
	d. Calculations (in Appendix)		
8	Flood Hazard Zone/Flood Plains		
	a. Discussion of Relevance/Impacts		
	b. References to Other Studies/Reports		
	c. Delineation on Maps/Drawings		
9	Conclusions		
	a. Compliance with Regulations		
	b. Project Impacts and Mitigation		
10	Drainage Plan		
	a. Topographic Contours		
	b. ROW and Easements		
	c. Delineation of Basins and Sub-Basins		
	d. Existing Drainage Patterns and Facilities		
	e. Proposed Drainage Patterns and Facilities		
	f. Proposed Outfall Points		
	g. Routing of Offsite Drainage		
11	Other as Stated		

SECTION 1600 - REFERENCES

AASHTO - *Load and Resistance Factor Design (LRFD) Bridge Design Specifications* (American Association of State Highway and Transportation Officials).

Abt, S.R., et al, 1989, Human Stability in a High Flood Hazard Zone, American Water Resources Association, Water Resources Bulletin, Vol. 25, No. 4, August 1989.

AISI, 1971 - *Handbook of Steel Drainage and Highway Construction Products* (American Iron and Steel Institute, Washington, D.C., 1971).

Akan, A.O. and R.J. Houghtalen, 2003 - *Urban Hydrology, Hydraulics, and Stormwater Quality: Engineering Applications and Computer Modeling* (New York, NY: John Wiley & Sons).

Anderson, 1968 - Anderson, A.G., Paintal, A.S., Davenport, J.T., *Tentative Design Procedure for Riprap Lined Channels* (University of Minnesota, St. Anthony Falls Hydraulics Laboratory, Project Design Report No. 96, 1968).

ASCE, 1975 - American Society of Civil Engineers, *Sedimentation Engineering, Manuals and Reports on Engineering Practice No. 54* (ASCE, New York, 1975).

ASTM (American Society for Testing and Materials) – Most current editions. See www.astm.org.

AWRA, 1989, *Water Resource Bulletin, Vol. 25, No. 4*.

Blodgett, 1986

Brater, 1976 - Brater and King, *Handbook of Hydraulics* (McGraw Hill Book Company, 1976).

Bruthurst, 1979 - J.C. Bruthurst, R.M. Li, and D.B. Simons, *Hydraulics of Mountain Rivers* (Civil Engineering Department, Colorado State University, CER78-78JCB-RML-DBS55, 1979).

Cedegren, 1967 - H.R. Cedegren, *Seepage Drainage and Flow Nets* (John Wiley and Sons, Inc., New York, 1967).

Chow, 1959 - Chow, V. T., *Open Channel Hydraulics* (McGraw-Hill Book Company, 1959).

Chow, 1964 - Chow, V. T., *Handbook of Applied Hydrology* (McGraw-Hill Book Company, 1964).

City of North Las Vegas, *Onsite Stormwater Detention Manual* (1984).

City of Reno, *Major Drainageways Plan* (June 1992).

City of Reno, *Public Works Design Manual* (March 2, 1992).

City of Reno, *Section 18.06.315 Hillside Developments, Ordinance 3841* (August 17, 1989).

City of Reno, *Truckee Meadows Structural Controls Design Manual*.

City of Reno, *Truckee Meadows Construction Best Management Practices Handbook*.

City of Reno, *Wetland and Stream Environment Policy* (September 1991).

Cooke, 1973 - Cooke, R. U. and Warren, A., *Geomorphology in Deserts* (University of California Press, Berkeley and Los Angeles, California, 1973).

Denver Urban Drainage and Flood Control District, 2001 - *Drainage Criteria Manual*.

FAA, 1970 - *Airport Drainage, Advisory Circular 150/5320-5B* (US Department of Transportation, Federal Aviation Administration, Washington, DC, 1970).

- Federal Interagency Stream Restoration Work Group (FISWRG), *Stream Corridor Restoration: Principles, Processes, and Practices* (2001).
- Flood Control Master Plan Technical Advisory Committee, *Agency Responsibility Memorandum* (Kennedy/Jenks Consultants, October 1991).
- Fortier, 1926 - S. Fortier and F. C. Scobey, *Permissible Canal Velocities, Transactions* (American Society of Civil Engineers, Volume 89, pp 940-956, 1926).
- French, 1985 - French, R. H., *Open-Channel Hydraulics* (McGraw-Hill Book Company, New York, 1985).
- Goldman, 1986 - S. J. Goldman, K. Jackson, T. A. Bursztyusky, *Erosion and Sediment Control Handbook* (McGraw Hill, 1986).
- Guo, J.C.Y., 1999 - *Storm Water System Design* (CE5803, University of Colorado at Denver).
- HEC, 1990 - *HEC-1 Flood Hydrograph Package, Users Manual* (US Army Corps of Engineers, The Hydrologic Engineering Center, Davis, California, [with current program revisions]).
- HMR 49, 1977 - Hansen E.M., Schwarz F.K., Riedal J.T., *Probable Maximum Precipitation Estimates, Colorado River and Great Basin Drainages, Hydrometeorological Report No. 49* (US Department of Commerce, September, 1977).
- Hoggan, 1989 - Hoggan, D.H., *Computer Assisted Floodplain Hydrology and Hydraulics* (McGraw-Hill Book Company, 1989).
- Hopkins, 1956 - *The Design of Storm-Water Inlets* (John Hopkins University, Department of Sanitary Engineering and Water Resources, Baltimore, Maryland, June, 1956).
- Humphrey, John H., Ph.D., *Washoe County Flood Control Master Plan/Meteorological Analysis* (April 1994).
- IAC, 1982 - *Guidelines for Determining Flood Flow Frequency - Bulletin No. 17B, Interagency Advisory Committee on Water Data*, (US Department of the Interior, Geological Survey, March, 1982).
- Izzard, 1977 - Izzard, Carl F., *Hydraulic Capacity of Curb Opening Inlets, Flood Hazard News* (UD&FCD, Denver, Colorado, June, 1977).
- LACFCD, 1982 - *Design Manual, Hydraulic* (Los Angeles County Flood Control District, March 1982).
- LADPW, 1989 - *Hydrology Manual* (Los Angeles County Department of Public Works, Alhambra, California, December 1971, revised March 1989).
- Lane, 1935 - E.W. Lane, *Security from Under Seepage* (Transactions ASCE, Vol. 100, 1935).
- Linsley, 1964 - Linsley, R. K., and Franzini, J. B., *Water Resources Engineering* (McGraw-Hill Book Company, USA, 1964).
- Linsley, 1975 - Linsley, Kohler, and Paulhus, *Hydrology for Engineers, 2nd Edition* (McGraw-Hill Company, New York, 1975).
- McLaughlin Water Engineers, Ltd., *Evaluation of and Design Recommendations for Drop Structures in the Denver Metropolitan Area* (December 1986).
- NDOT, 1975 - *Design Manual* (Nevada Department of Transportation, Hydrologic Design Section, 1975).
- NOAA, 1984 - *Depth-Area Ratios in the Semi-Arid Southwest United States*, (NOAA Technical Memorandum NWS Hydro-40, US Department of Commerce, National Oceanic and Atmospheric Administration, August 1984).
- NOAA Atlas 2 - *Precipitation-Frequency Atlas of the Western United States, Volume VII- Nevada* (NOAA, 1973 - US Department of Commerce, National Oceanic and Atmospheric Administration, National Weather Service, Silver Springs, MD, 1973).

- NRS 278, Nevada Revised Statutes Related to Regional Planning.
- NRS 487, Nevada Revised Statutes Creating the Regional Water Planning and Advisory Board of Washoe County (Regional Water Resources Management Agency/RWRMA).
- NRS 543, Nevada Revised Statutes Related to Flood Control Districts that cover the entire county.
- Peterka, 1978 - A. J. Peterka, *Hydraulic Design of Stilling Basins and Energy Dissipators, EM No. 25* (US Department of the Interior, Bureau of Reclamation, Denver, Colorado, 1978).
- Quad Knopf, 2007, *North Valleys Flood Control Hydrologic Analysis and Mitigation Options, Volumes I and II*; (Prepared for the Washoe County Regional Water Planning Commission and the City of Reno, March 30, 2007).
- SCS, 1983 - *TR-20 Computer Program for Project Formulation Hydrology* (US Department of Agriculture, Soil Conservation Service, Washington, DC, May 1983).
- SCS, 1985 - *Natural Engineering Handbook, Section 4, Hydrology* (US Department of Agriculture, Soil Conservation Service, Washington, DC, March 1985).
- SCS, 1986 - *TR-55 Urban Hydrology for Small Watersheds* (US Department of Agriculture, Soil Conservation Service, Washington, DC, June 1986).
- SCS, 1989, Minnesota Technical Release 3, July 1989, Loose Riprap Protection.
- SCS, 1996 – *The NRCS Engineering Field Handbook, Part 650, Chapter 16, Streambank and Shoreline Protection* (USDA-NRCS 1996).
- SCS, 1996 – *The NRCS Engineering Field Handbook, Part 650, Chapter 18, Soil Bioengineering for Upland Slope Protection and Erosion Reduction* (USDA-NRCS 1992).
- Simons, 1981 - *Design Guidelines and Criteria for Channels and Hydraulic Structures on Sandy Soils* (Simons, Li, and Associates, prepared for Urban Drainage and Flood Control District and City of Aurora, Colorado, June 1981).
- Simons, 1989 - Simons, Li and Associates, *Surface Mining Water Diversion Design Manual* (September 1982), US Department of Interior, Office of Surface Mining Reclamation and Enforcement, 1989).
- Smith, 1965 - Smith, C.D., and Murray, D.G., *Cobble Lined Drop Structures* (2nd Canadian Hydro-Technical Conference, Burlington, Ontario, 1965).
- SSPFS, 1997 - *Precipitation Frequency Study of the United States*, (NOAA Atlas 14, Volume 1 - Semi-Arid Southwest United States [Draft Maps], April 1997).
- State of Nevada, 1986 - *Standard Specifications for Road and Bridge Construction* (State of Nevada, Department of Transportation, 1986).
- Stevens, 1981 - Stevens, Michael, A., *Hydraulic Design Criteria for Riprap Chutes and Vertical Drop Structures* (Urban Drainage and Flood Control District, 1981).
- Tarleton-Julian, Personal Correspondence, (US Department of Commerce, National Oceanic and Atmospheric Administration, National Weather Service, Office of Hydrology, Silver Springs, MD, May 14, 1996).
- Taylor, 1967 - Taylor, D.W., *Fundamentals of Soil Mechanics* (John Wiley and Sons, 1967).
- Truckee Meadows Regional Planning Agency, *Truckee Meadows Regional Plan*, (2008).
- UD&FCD, 1990 - *Grouted Riprap and Boulder Installations, Supplement to Urban Storm Drainage Criteria Manual* (Denver Urban Drainage and Flood Control District, 1982).
- USACE, 1990A - *HEC-1, Flood Hydrograph Package*, (US Army Corps of Engineers, Davis, California, September 1990).

- USACE, 1979 - *Introduction and Application of Kinematic Wave Routing Techniques Using HEC-1, Training Document No. 10* (US Army Corps of Engineers Davis, California, May 1979).
- USACE, 1970 - *Hydraulic Design of Flood Control Channels, EM 1110-2-1601* (US Army Corps of Engineers, Washington, DC, July 1970).
- USACE, 1990B - *HEC-2, Water Surface Profiles* (Davis, California, September 1990).
- USBR, 1967 - *Canals and Related Structures, Design Standards No. 3* (US Department of the Interior, Bureau of Reclamation, Denver, Colorado, 1967).
- USBR, 1974 - *Design of Small Canal Structures* (US Department of the Interior, Bureau of Reclamation, Denver, Colorado, 1974).
- USBR, 1987 - *Design of Small Dams* (US Department of the Interior, Bureau of Reclamation, Washington, DC, 1987).
- USBR, 1989 - *Flood Hydrology Manual* (US Department of the Interior, Bureau of Reclamation, Washington, DC, 1989).
- USDA, 1976 - *Sedimentation Deposition in US Reservoirs, Summary of Data Reported through 1975* (US Department of Agriculture, Washington, DC, 1976).
- USDCEM, 1969 - *Urban Storm Drainage Criteria Manual* (Denver Regional Council of Governments, Denver, Colorado, March, 1969 [with current revisions]).
- USDOT, 1971 - *Debris Control Structures, EPD-86-106, HEC 9* (US Department of Transportation, Federal Highway Administration, Washington, DC, 1971).
- USDOT, 1978 - *Hydraulics of Bridge Waterways, Hydraulic Design Series No. 1* (US Department of Transportation, Federal Highway Administration, Washington, DC, March, 1978).
- USDOT, 1983 - *Hydraulic Design of Energy Dissipators for Culverts and Channels, Hydraulic Engineering Circular No. 14* (US Department of Transportation, Federal Highway Administration, Washington, DC, September 1983).
- USDOT, 1985 - *Hydraulic Design of Highway Culverts, Hydraulic Design Series No. 5* (US Department of Transportation, Federal Highway Administration, McLean, Virginia, September 1985).
- USDOT, 1989 - *Design of Riprap Revetment, Hydraulic Engineering Circular No. 11* (US Department of Transportation, Federal Highway Administration, McLean, Virginia, March 1989).
- USDOT, 1991A - *Stream Stability at Highway Structures, Hydraulic Engineering Circular No. 20* (US Department of Transportation, Federal Highway Administration, McLean, Virginia, February 1991).
- USDOT, 1991B - *Evaluating Scour at Bridges, Hydraulic Engineering Circular No. 18* (US Department of Transportation, Federal Highway Administration, McLean, Virginia, February 1991).
- USEPA, 1976 - *Erosion and Sediment Control, Surface Mining in the Eastern US* (US Environmental Protection Agency, EPA-625/3-76-006, Washington, DC, 1976).
- USDOT, 2001 - *Stream Stability at Highway Structures No. 20* (US Department of Transportation, Federal Highway Administration, 2001).
- USDOT, 2001 - *Evaluating Scour at Bridges, Hydraulic Engineering Circular No. 18* (US Department of Transportation, Federal Highway Administration, 2001).
- USDOT, 2001 - *Urban Drainage Design Manual, Hydraulic Engineering Circular No. 22* (US Department of Transportation, Federal Highway Administration, August 2001).
- Washoe Council of Governments - *Washoe County Flood Control Master Plan* (Kennedy/Jenks/Chilton, Inc., August 1990).

Washoe County - *Cooperation Agreement between Washoe County and the Soil Conservation Service RE: Floodplain Management Study for East Washoe Valley* (March 1994).

Washoe County - *Evans Creek Watershed Plan and Environmental Assessment* (August 1994).

Washoe County - *Flood Control Projects* (May 24, 1994).

Washoe County - *Regional Water Supply and Quality Study* (January 1994).

Washoe County - *Washoe County Development Code/Article 416-Flood Hazards*.

Washoe County - *Washoe County Development Code/Article 420-Storm Drainage Standards*.

Washoe County and Cities of Reno and Sparks – *Comprehensive Regional Water Management Plan*

Washoe County and Cities of Reno and Sparks - *Washoe County Flood Control Master Plan, Volumes I & II*, (April 1991).

Washoe County Department of Comprehensive Planning - *Draft Development Standards and Design Guidelines* (July 1994).

Washoe County Department of Public Works, *Construction Activities/Best Management Practice Handbook*, June 1994.

Washoe County Department of Public Works - *Preliminary Whites Creek Basin Management Study* (Cella Barr Associates, August 1994).

WRC Engineering, Inc., - *Clark County Regional Flood Control District, Hydrologic Criteria and Drainage Design Manual* (Las Vegas, Nevada 1990)